

CS-21-189

Contract Tracking No.: CM3150

Bid No.: NC21-014

CONTRACT FOR CONSTRUCTION OF THE SAFETY IMPROVEMENTS OF CR-121, S. 14TH ST., CHESTER RD., SADLER RD., AND AMELIA CONCOURSE

THIS AGREEMENT is dated as of the 28 day of February in the year 2022 by and between
NASSAU COUNTY BOCC (Owner) and
ACME BARRICADES L.C. (Contractor).

Owner and Contractor, in consideration of the mutual covenants hereinafter set forth, agree as follows:

ARTICLE 1 - WORK

1.01 The Contractor shall complete all work as specified or indicated in the Contract Documents as defined in Article 10. The work is generally described as follows: This project consists of signing and pavement marking upgrades in various locations along CR-121, S. 14TH ST., CHESTER RD., SADLER RD., and AMELIA CONCOURSE in Nassau County, Florida.

All work shall be in accordance with the construction drawings, specifications, and contract documents. **BIDDERS MUST BE FDOT PRE-QUALIFIED in the following Major Work Classes; "Pavement Marking" and "Roadway Signing".**

ARTICLE 2 -THE PROJECT

2.01 The Project is for the Work referenced in Article 1 and the Contract Documents and generally described as follows:

CR-121, S. 14TH ST., CHESTER RD., SADLER RD., and AMELIA CONCOURSE
Bid Number NC21-014
Nassau County, Florida

ARTICLE 3 - ENGINEER

3.01 Managing authority for this project shall be the Nassau County Engineer, Robert Companion, P.E. or his authorized designee.

ARTICLE 4 - ENGINEER OF RECORD

4.01 The Project has been designed by the Florida Department of Transportation who is to assume all duties and responsibilities and have the rights and authority assigned to Engineer of Record in the Contract Documents in connection with completion of the Work in accordance with the Contract Documents.

ARTICLE 5 - CONTRACT TIMES

5.01 Time of the Essence

- A. All time limits for Milestones, if any, Substantial Completion, and completion and readiness for final payment as stated in the Contract Documents are of the essence of the Contract.
- B. The Contractor hereby agrees to commence work under this contract on a date to be specified in written "Notice to Proceed" of the County and to fully complete the Project as specified in Section 5.02 of this Contract.
- C. Under no condition, shall written Notice to Proceed be issued until Contractor has provided the

Performance Bonds specified in Section 5.01 of the General Conditions.

5.02 Days to Achieve Substantial Completion and Final Payment

The Work will be substantially completed within 45 days after the date when the Contract Times commence to run as provided in Paragraph 2.03 of the General Conditions, and completed and ready for final payment in accordance with Paragraph 14.07 of the General Conditions within 15 calendar days from the date of substantial completion. Total contract time shall be 60 calendar days; for everyday the work goes beyond substantial completion, a day will be removed from final completion so the total days equal 60 calendar days.

5.03 Liquidated Damages (See LAP Division 1 Sec. 8-10)

~~A. Contractor and the County recognize that time is of the essence of this Agreement and that the County will suffer financial loss if the Work is not completed within the times specified in Paragraph 4.02 above, plus any extensions thereof allowed in accordance with Article 12 of the General Conditions. The parties also recognize the delays, expense, and difficulties involved in proving in legal or arbitration proceeding the actual loss suffered by the County if the Work is not completed on time. Accordingly, instead of requiring any such proof, the County and Contractor agree that as liquidated damages for delay (but not as a penalty) Contractor shall pay the County \$2,712.00 for each day that expires after the time specified in Paragraph 4.02 for Substantial Completion and until the Work is substantially complete. After Substantial Completion, if Contractor shall neglect, refuse, or fail to complete the remaining Work within the Contract Time or any proper extension thereof granted by the County, Contractor shall pay the County \$2,712.00 for each day that expires after the time specified in Paragraph 4.02 for completion and readiness for final payment until the Work is completed and ready for final payment.~~

ARTICLE 6 - CONTRACT PRICE

6.01 The County shall pay Contractor for completion of the Work in accordance with the General Conditions and Contract Documents an amount in current funds equal to the sum of the amounts determined pursuant to Article 14 "Payments to Contractor" of the General Conditions and Paragraphs 6.01A and 6.01 B below:

- A. For all Work, at the prices stated in the Contractor's Bid, attached hereto as an exhibit.
- B. For all Unit Price Work, an amount equal to the sum of the established unit price for each separately identified item of Unit Price Work times the estimated quantity of that item as indicated in Contractor's Bid (attached hereto as an exhibit) for a Total of All Unit Prices of:

SIX HUNDRED FIFTY-EIGHT THOUSAND SEVENTEEN DOLLARS AND SIXTY CENTS

(use words)

\$658,017.60

(figures)

As provided in Paragraph 11.03 of the General Conditions, estimated quantities are not guaranteed, and determinations of actual quantities and classification are to be made by Engineer of Record as provided in Paragraph 9.07 of the General Conditions. The final payment for all Unit Price Work shall be an amount equal to the sum of the established unit price for each separately identified item of Unit Price Work times the actual completed and accepted quantity of each item. Unit Prices have been computed as provided in Paragraph 11.03 of the General Conditions.

ARTICLE 7 - PAYMENT PROCEDURES

7.01 Submittal and Processing of Payments

- A. Contractor shall submit Applications for Payment in accordance with Article 14 of the General Conditions. Applications for Payment will be processed by the County as provided in the General Conditions.

7.02 Progress Payments; Retainage

- B. The County shall make progress payments on account of the Contract Price on the basis of Contractor's Applications for Payment once each month during performance of the Work as provided in Paragraphs 7.02.A.1 and 7.02.A.2 below. All such payments will be measured by the schedule of values established as provided in Paragraph 2.07A of the General Conditions (and in the case of Unit Price Work based on the number of units completed) or, in the event there is no schedule of values, as provided in the General Requirements:

- 1. Prior to Substantial Completion, progress payments will be made in an amount equal to the percentage indicated below, but, in each case, less the aggregate of payments previously made and less such amounts as Engineer of Record may determine or the County may withhold, including but not limited to liquidated damages, in accordance with Paragraph 14.02 of the General Conditions:
 - a. 95% percent of the Work completed (with the balance being retainage)
 - b. 95% percent of cost of materials and equipment not incorporated in the Work (with the balance being retainage).

7.03 Final Payment

- C. Upon final completion and acceptance of the Work in accordance with Paragraph 14.07 of the General Conditions, the County shall pay the remainder of the Contract Price as recommended by Engineer of Record as provided in said Paragraph 14.07.
- D. Final Release of Retainage and acceptance of the project must be approved by the Board of County Commissioners.

ARTICLE 8 - INTEREST

- 8.01** All moneys not paid when due will be paid according to the Florida Department of Transportation (FDOT) Supplemental LAP Specifications for payment requirements.

ARTICLE 9 - CONTRACTOR'S REPRESENTATIONS

- 9.01** In order to induce the County to enter into this Contract, Contractor makes the following representations:
- A. Contractor has examined and carefully studied the Contract Documents and the other related data identified in the Bidding Documents.
 - B. Contractor has examined and carefully studied the Contract Documents including the General Conditions and the other related data identified in the Bidding Documents.
 - C. Contractor has visited the Site and become familiar with and is satisfied as to the general, local, and Site conditions that may affect cost, progress, and performance of the Work.
 - D. Contractor is familiar with and is satisfied as to all federal, state, and local Laws and Regulations that may affect cost, progress, and performance of the Work.
 - E. Contractor has carefully studied all: (1) reports of explorations and tests of subsurface conditions at or contiguous to the Site and all drawings of physical conditions in or relating to existing surface or subsurface structures at or contiguous to the Site (except Underground Facilities) which have been identified in the plans and technical specifications as provided in Paragraph 4.02 of the General Conditions and (2) reports and drawings of a Hazardous Environmental Condition, if any, at the Site which has been identified in the plans and technical specifications as provided in Paragraph 4.06 of the General Conditions.
 - F. Contractor has obtained and carefully studied (or assumes responsibility for having done so) all additional or supplementary examinations, investigations, explorations, tests, studies, and data concerning conditions (surface, subsurface, and Underground Facilities) at or contiguous to the Site which may affect cost, progress, or performance of the Work or which relate to any aspect of the means, methods, techniques, sequences, and procedures of construction to be employed by Contractor, including applying the specific means, methods, techniques, sequences, and procedures of construction, if any, expressly required by the Bidding Documents, and safety precautions and programs incident thereto.
 - G. Contractor does not consider that any additional examinations, investigations, explorations, tests, studies, or data are necessary for the performance of the Work at the Contract Price, within the Contract Times, and in accordance with the other terms and conditions of the Contract Documents.
 - H. Contractor is aware of the general nature of work to be performed by the County and others at the Site that relates to the Work as indicated in the Contract Documents.
 - I. Contractor has correlated the information known to Contractor, information and observations obtained from visits to the Site, reports and drawings identified in the Contract Documents, and all additional examinations, investigations, explorations, tests, studies, and data with the Contract Documents.

- J. Contractor has given Engineer and Engineer of Record written notice of all conflicts, errors, ambiguities, or discrepancies that Contractor has discovered in the Contract Documents, and the written resolution thereof by Engineer and Engineer of Record is acceptable to Contractor.
- K. The Contract Documents are generally sufficient to indicate and convey understanding of all terms and conditions for performance of the Work.

ARTICLE 10 - CONTRACT DOCUMENTS

10.01 Contents

- A. The Contract Documents consist of the following:
 - 1. This Contract
 - 2. Project Manual (enumerated as follows):
 - a. Project Manual table of contents
 - b. General Conditions
 - c. Supplementary Conditions
 - d. Plans and Technical Specifications
 - e. Appendixes
 - f. Addenda, if any
 - 3. Exhibits to this Contract (enumerated as follows):
 - a. General Information and Minimum Insurance Requirements
 - b. Contractor's Bid
 - 4. Documentation submitted by Contractor prior to Notice of Award
 - 5. Drawing Index, if any
 - 6. The following which may be delivered or issued on or after the Effective Date of the Contract and are not attached hereto:
 - a. Payment Bond
 - b. Performance Bond
 - c. Certificate of Liability Insurance

- d. Notice to Proceed
 - e. Work Change Directives
 - f. Change Orders
 - g. Certificate of Substantial Completion
 - h. Certificate of Final Inspection
 - i. Certificate of Engineer
 - j. Certificate of Final Completion
 - k. CONTRACTOR'S release of Performance Bond
 - l. Construction Drawings and plans/ As-Built Drawings
 - m. Supplemental Agreements
 - n. CONTRACTOR'S Waiver of Lien (Partial)
 - o. CONTRACTOR'S Waiver of Lien (Final and Complete)
 - p. Subcontractor/Vendor's Waiver of Lien (Final and Complete)
 - q. Consent of Surety to Final Payment
 - r. Contractor's Insurance Requirements, as set forth in the Bid Documents
- B. The documents listed in Paragraph 9.01.A are attached to this Contract (except as expressly noted otherwise above).
- C. There are no Contract Documents other than those listed above in this Article 10.
- D. The Contract Documents may only be amended, modified, or supplemented as provided in Paragraph 3.04 of the General Conditions.

ARTICLE 11 - MISCELLANEOUS

11.01 Terms

- A.** Terms used in this Contract will have the meanings indicated in the General Conditions and the Supplementary Conditions.

11.02 Assignment of Contract

- A. No assignment by a party hereto of any rights under or interests in the Contract will be binding on another party hereto without the written consent of the party sought to be bound; and, specifically but without limitation, moneys that may become due and moneys that are due may not be assigned without such consent (except to the extent that the effect of this restriction may be limited by law), and unless specifically stated to the contrary in any written consent to an assignment, no assignment will release or discharge the assignor from any duty or responsibility under the Contract Documents.

11.03 Successors and Assigns

- A. The County and Contractor each binds itself, its partners, successors, assigns, and legal representatives to the other party hereto, its partners, successors, assigns, and legal representatives in respect to all covenants, agreements, and obligations contained in the Contract Documents.

11.04 Severability

- A. Any provision or part of the Contract Documents held to be void or unenforceable under any Law or Regulation shall be deemed stricken, and all remaining provisions shall continue to be valid and binding upon the County and Contractor, who agree that the Contract Documents shall be reformed to replace such stricken provision or part thereof with a valid and enforceable provision that comes as close as possible to expressing the intention of the stricken provision.

11.05 Other Provisions

- A. The County entered into an Agreement between the County and the State of Florida Department of Transportation, dated February 8, 2021, Contract Nos. 441217-1-58-01 and 441217-1-58-02 (the "LAP Agreement"). The Contractor shall comply with all the provisions of the LAP Agreement, including Appendices A and E attached hereto, that are assignable to the Contractor under this Agreement. In addition, the Contractor understands and agrees that there are requirements in the LAP Agreement that require the County to include specific provisions of such LAP Agreement in this Agreement, and to require the Contractor to include those specific provisions in any subcontract with a subcontractor ("LAP provisions"). The parties agree that such LAP provisions are incorporated herein by this reference. The Contractor agrees to comply with all the LAP provisions and to set out the LAP provisions in any subcontract. The LAP Agreement is attached hereto as Exhibit 2.

B. Public Records Requirement:

The County is a public agency subject to Chapter 119, Florida Statutes. IF THE CONTRACTOR HAS QUESTIONS REGARDING THE APPLICATION OF CHAPTER 119, FLORIDA STATUTES, TO THE CONTRACTOR'S DUTY TO PROVIDE PUBLIC RECORDS RELATING TO THIS CONTRACT, CONTACT THE CUSTODIAN OF PUBLIC RECORDS AT (904) 530-6010, RECORDS@NASSAUCOUNTYFL.COM, 96135 NASSAU PLACE, SUITE 6, YULEE, FLORIDA 32097 or visit our website at [www.nassaucountyfl.com/178/ Public-Records-Requests](http://www.nassaucountyfl.com/178/Public-Records-Requests). Under this Contract, to the extent that the contractor is providing services to the County, and pursuant to Section 119.0701, Florida Statutes, the contractor shall:

- a. Keep and maintain public records required by the public agency to perform the service.
 - b. Upon request from the public agency's custodian of public records, provide the public agency with a copy of the requested records or allow the records to be inspected or copied within a reasonable time at a cost that does not exceed the cost provided in this chapter or as otherwise provided by law.
 - c. Ensure that public records that are exempt or confidential and exempt from public records disclosure requirements are not disclosed except as authorized by law for the duration of the Contract term and following completion of the Contract if the Contractor does not transfer the records to the public agency.
 - d. Upon completion of the Contract, transfer, at no cost, to the public agency all public records in possession of the Contractor or keep and maintain public records required by the public agency to perform the service. If the Contractor transfers all public records to the public agency upon completion of the Contract, the Contractor shall destroy any duplicate public records that are exempt or confidential and exempt from public records disclosure requirements. If the Contractor keeps and maintains public records upon completion of the Contract, the Contractor shall meet all applicable requirements for retaining public records. All records stored electronically must be provided to the public agency, upon request from the public agency's custodian of public records, in a format that is compatible with the information technology systems of the public agency.
 - e. A request to inspect or copy public records relating to a County contract for services must be made directly to the County's Custodian of Public Records. If the County does not possess the requested records due to the Contractor maintaining the public records, the County shall immediately notify the Contractor of the request for records. The Contractor must provide the records to the County or allow the records to be inspected or copied within a reasonable time. If the Contractor does not comply with the County's request for records, the County shall be entitled to enforce the Contract provisions herein for failure to comply with the terms of the Contract. Any Contractor which fails to provide public records to the County within a reasonable time may also be subject to penalties as provided under Section 119.10, Florida Statutes, including punishment by fine or may be guilty of committing a misdemeanor of the first degree for any willful and knowing violation.
- C. Employment Eligibility:**
Contractor must comply with F.S.448.095 and use the United States Department of Homeland Security's E-Verify System ("E-Verify") to verify the employment eligibility of all persons hired by Contractor during the term of this Contract to work in Florida. Additionally, if Contractor uses Subcontractor to perform any portion of the work (under the Contract) Contractor must include a requirement in the Subcontractor's contract that the Subcontractor uses E-Verify to verify the employment eligibility of all persons hired by Subcontractor to perform any such portion of the work. Answers to questions regarding E-Verify as well as instructions or enrollment may be found at the E-Verify website: www.uscis.gov/e-verify.

[Remainder of page intentionally left blank]

IN WITNESS WHEREOF, the County and Contractor have signed this Contract in triplicate. One counterpart each has been delivered to the County, Contractor, the Engineer and Engineer of Record. All portions of the Contract Documents have been signed or identified by the County and Contractor or identified by Engineer and Engineer of Record on their behalf.

This Contract will be effective on the date on which the Contract is signed and delivered by the last of the two parties to sign and deliver (which is the Effective Date of the Contract).

OWNER

Nassau County Board of County Commissioners

Signed: 

Title: Aaron C. Bell, Chairman

Date: 2/28/2022

[CORPORATE SEAL]

Attest: _____

Title: John A. Crawford, Ex-Officio Clerk

Address for giving notices:
Nassau County Board of County Comm.
96135 Nassau Place
Yulee, FL 32097
Phone: _____ FAX: _____

CONTRACTOR

Signed: _____

Title: _____

Date: _____

[CORPORATE SEAL]

Attest: _____

Title: _____

Address for giving notices:

Phone: _____ FAX: _____
License _____
(Where applicable)

Approved as to form by County Attorney
Agent for service of process

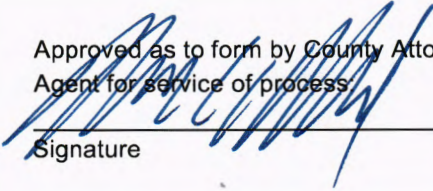
Signature

(If Owner is a corporation, attach evidence of authority to sign. If Owner is a public body, attach evidence of authority to sign and resolution or other documents authorizing execution of Owner-Contractor Contract).

(If Contractor is a corporation or a partnership, attach evidence of authority to sign.)

Contract Tracking No.: CM3150
Bid No.: NC21-014

IN WITNESS WHEREOF, the County and Contractor have signed this Contract in triplicate. One counterpart each has been delivered to the County, Contractor, the Engineer and Engineer of Record. All portions of the Contract Documents have been signed or identified by the County and Contractor or identified by Engineer and Engineer of Record on their behalf.

This Contract will be effective on the date on which the Contract is signed and delivered by the last of the two parties to sign and deliver (which is the Effective Date of the Contract).

OWNER

Nassau County Board of County Commissioners

Signed: 

Title: Aaron C. Bell, Chairman

Date: 2/28/2022

[CORPORATE SEAL]

Attest: 

Title: John A. Crawford, Ex-Officio Clerk

Address for giving notices:
Nassau County Board of County Comm.
96135 Nassau Place

Yulee, FL 32097

Phone: _____ FAX: _____

CONTRACTOR

ACME Barricades LC

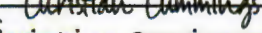
Signed: 

Title: Christian Cummings, CEO

Date: 3/15/2022

[CORPORATE SEAL]

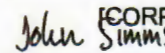
Attest: 

Title: Christian Cummings, CEO

Address for giving notices:
ACME Barricades LC
9800 Normandy Blvd.
Jacksonville, Florida 32221

Phone: 904-781-1950 FAX: _____

License: _____

(Where applicable)

Approved as to form by County Attorney
Agent for service of process

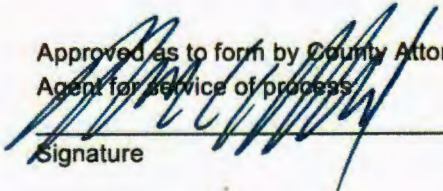
Signature

(If Owner is a corporation, attach evidence of authority to sign. If Owner is a public body, attach evidence of authority to sign and resolution or other documents authorizing execution of Owner-Contractor Contract).

(If Contractor is a corporation or a partnership, attach evidence of authority to sign.)

PROJECT MANUAL

PROJECT MANUAL FOR CONSTRUCTION OF THE SAFETY IMPROVEMENTS OF CR-
121, S. 14TH ST., CHESTER RD., SADLER RD., AND AMELIA CONCOURSE

A. Table of Contents

- A. Project Manual table of contents
- B. General Conditions
- C. Supplementary Conditions
- D. Plans and Technical Specifications
- E. Appendices
- F. Addenda (Not Included)

B. STANDARD GENERAL
CONDITIONS

STANDARD GENERAL CONDITIONS OF THE CONSTRUCTION CONTRACT

Prepared by

ENGINEERS JOINT CONTRACT DOCUMENTS COMMITTEE

and

Issued and Published Jointly by



AMERICAN COUNCIL OF ENGINEERING COMPANIES

ASSOCIATED GENERAL CONTRACTORS OF AMERICA

AMERICAN SOCIETY OF CIVIL ENGINEERS

PROFESSIONAL ENGINEERS IN PRIVATE PRACTICE
A Practice Division of the
NATIONAL SOCIETY OF PROFESSIONAL ENGINEERS

Endorsed by



CONSTRUCTION SPECIFICATIONS INSTITUTE

Copyright © 2007 National Society of Professional Engineers
1420 King Street, Alexandria, VA 22314-2794
(703) 684-2882
www.nspe.org

American Council of Engineering Companies
1015 15th Street N.W., Washington, DC 20005
(202) 347-7474
www.acec.org

American Society of Civil Engineers
1801 Alexander Bell Drive, Reston, VA 20191-4400
(800) 548-2723
www.asce.org

Associated General Contractors of America
2300 Wilson Boulevard, Suite 400, Arlington, VA 22201-3308
(703) 548-3118
www.agc.org

The copyright for this EJCDC document is owned jointly by the four EJCDC sponsoring organizations and held in trust for their benefit by NSPE.

STANDARD GENERAL CONDITIONS OF THE CONSTRUCTION CONTRACT

TABLE OF CONTENTS

	Page
Article 1 – Definitions and Terminology	1
1.01 Defined Terms	1
1.02 Terminology	5
Article 2 – Preliminary Matters	6
2.01 Delivery of Bonds and Evidence of Insurance	6
2.02 Copies of Documents	6
2.03 Commencement of Contract Times; Notice to Proceed	6
2.04 Starting the Work	7
2.05 Before Starting Construction	7
2.06 Preconstruction Conference; Designation of Authorized Representatives	7
2.07 Initial Acceptance of Schedules	8
Article 3 – Contract Documents: Intent, Amending, Reuse	8
3.01 Intent	8
3.02 Reference Standards	8
3.03 Reporting and Resolving Discrepancies	9
3.04 Amending and Supplementing Contract Documents	10
3.05 Reuse of Documents	10
3.06 Electronic Data	10
Article 4 – Availability of Lands; Subsurface and Physical Conditions; Hazardous Environmental Conditions; Reference Points	11
4.01 Availability of Lands	11
4.02 Subsurface and Physical Conditions	11
4.03 Differing Subsurface or Physical Conditions	12
4.04 Underground Facilities	13
4.05 Reference Points	14
4.06 Hazardous Environmental Condition at Site	14
Article 5 – Bonds and Insurance	16
5.01 Performance, Payment, and Other Bonds	16
5.02 Licensed Sureties and Insurers	17
5.03 Certificates of Insurance	17
5.04 Contractor’s Insurance	18
5.05 Owner’s Liability Insurance	20
5.06 Property Insurance	20
5.07 Waiver of Rights	21
5.08 Receipt and Application of Insurance Proceeds	22
5.09 Acceptance of Bonds and Insurance; Option to Replace	23

5.10	Partial Utilization, Acknowledgment of Property Insurer.....	23
Article 6 – Contractor’s Responsibilities		
6.01	Supervision and Superintendence	23
6.02	Labor; Working Hours.....	24
6.03	Services, Materials, and Equipment.....	24
6.04	Progress Schedule	25
6.05	Substitutes and “Or-Equals”	25
6.06	Concerning Subcontractors, Suppliers, and Others	28
6.07	Patent Fees and Royalties	29
6.08	Permits.....	30
6.09	Laws and Regulations.....	30
6.10	Taxes.....	31
6.11	Use of Site and Other Areas	31
6.12	Record Documents	32
6.13	Safety and Protection	32
6.14	Safety Representative.....	33
6.15	Hazard Communication Programs.....	33
6.16	Emergencies	33
6.17	Shop Drawings and Samples	33
6.18	Continuing the Work	35
6.19	Contractor’s General Warranty and Guarantee.....	36
6.20	Indemnification	36
6.21	Delegation of Professional Design Services.....	37
Article 7 – Other Work at the Site.....		
7.01	Related Work at Site	38
7.02	Coordination.....	38
7.03	Legal Relationships.....	39
Article 8 – Owner’s Responsibilities.....		
8.01	Communications to Contractor	39
8.02	Replacement of Engineer	39
8.03	Furnish Data	39
8.04	Pay When Due	39
8.05	Lands and Easements; Reports and Tests.....	39
8.06	Insurance.....	40
8.07	Change Orders	40
8.08	Inspections, Tests, and Approvals.....	40
8.09	Limitations on Owner’s Responsibilities.....	40
8.10	Undisclosed Hazardous Environmental Condition.....	40
8.11	Evidence of Financial Arrangements.....	40
8.12	Compliance with Safety Program.....	40
Article 9 – Engineer’s Status During Construction		
9.01	Owner’s Representative	40
9.02	Visits to Site	41
9.03	Project Representative.....	41

9.04	Authorized Variations in Work.....	41
9.05	Rejecting Defective Work.....	42
9.06	Shop Drawings, Change Orders and Payments.....	42
9.07	Determinations for Unit Price Work.....	42
9.08	Decisions on Requirements of Contract Documents and Acceptability of Work.....	42
9.09	Limitations on Engineer's Authority and Responsibilities.....	43
9.10	Compliance with Safety Program.....	43
Article 10	– Changes in the Work; Claims.....	44
1001	Authorized Changes in the Work.....	44
1002	Unauthorized Changes in the Work.....	44
1003	Execution of Change Orders.....	44
1004	Notification to Surety.....	44
1005	Claims.....	45
Article 11	– Cost of the Work; Allowances; Unit Price Work.....	46
1101	Cost of the Work.....	46
1102	Allowances.....	48
1103	Unit Price Work.....	49
Article 12	– Change of Contract Price; Change of Contract Times.....	50
1201	Change of Contract Price.....	50
1202	Change of Contract Times.....	51
1203	Delays.....	51
Article 13	– Tests and Inspections; Correction, Removal or Acceptance of Defective Work.....	52
1301	Notice of Defects.....	52
1302	Access to Work.....	52
1303	Tests and Inspections.....	52
1304	Uncovering Work.....	53
1305	Owner May Stop the Work.....	54
1306	Correction or Removal of Defective Work.....	54
1307	Correction Period.....	54
1308	Acceptance of Defective Work.....	55
1309	Owner May Correct Defective Work.....	56
Article 14	– Payments to Contractor and Completion.....	56
1401	Schedule of Values.....	56
1402	Progress Payments.....	57
1403	Contractor's Warranty of Title.....	60
1404	Substantial Completion.....	60
1405	Partial Utilization.....	61
1406	Final Inspection.....	61
1407	Final Payment.....	61
1408	Final Completion Delayed.....	62
1409	Waiver of Claims.....	63

Article 15 – Suspension of Work and Termination 63

 1501 Owner May Suspend Work..... 63

 1502 Owner May Terminate for Cause 63

 1503 Owner May Terminate For Convenience 65

 1504 Contractor May Stop Work or Terminate 65

Article 16 – Dispute Resolution 66

 16.01 Methods and Procedures 66

Article 17 – Miscellaneous 65

 17.01 Giving Notice 65

 17.02 Computation of Times 66

 17.03 Cumulative Remedies 67

 17.04 Survival of Obligations 67

 17.05 Controlling Law 67

 17.06 Headings..... 67

ARTICLE 1 – DEFINITIONS AND TERMINOLOGY

1.01 *Defined Terms*

- A. Wherever used in the Bidding Requirements or Contract Documents and printed with initial capital letters, the terms listed below will have the meanings indicated which are applicable to both the singular and plural thereof. In addition to terms specifically defined, terms with initial capital letters in the Contract Documents include references to identified articles and paragraphs, and the titles of other documents or forms.
1. *Addenda*—Written or graphic instruments issued prior to the opening of Bids which clarify, correct, or change the Bidding Requirements or the proposed Contract Documents.
 2. *Agreement*—The written instrument which is evidence of the agreement between Owner and Contractor covering the Work.
 3. *Application for Payment*—The form acceptable to Engineer which is to be used by Contractor during the course of the Work in requesting progress or final payments and which is to be accompanied by such supporting documentation as is required by the Contract Documents.
 4. *Asbestos*—Any material that contains more than one percent asbestos and is friable or is releasing asbestos fibers into the air above current action levels established by the United States Occupational Safety and Health Administration.
 5. *Bid*—The offer or proposal of a Bidder submitted on the prescribed form setting forth the prices for the Work to be performed.
 6. *Bidder*—The individual or entity who submits a Bid directly to Owner.
 7. *Bidding Documents*—The Bidding Requirements and the proposed Contract Documents (including all Addenda).
 8. *Bidding Requirements*—The advertisement or invitation to bid, Instructions to Bidders, Bid security of acceptable form, if any, and the Bid Form with any supplements.
 9. *Change Order*—A document recommended by Engineer which is signed by Contractor and Owner and authorizes an addition, deletion, or revision in the Work or an adjustment in the Contract Price or the Contract Times, issued on or after the Effective Date of the Agreement.
 10. *Claim*—A demand or assertion by Owner or Contractor seeking an adjustment of Contract Price or Contract Times, or both, or other relief with respect to the terms of the Contract. A demand for money or services by a third party is not a Claim.
 11. *Contract*—The entire and integrated written agreement between the Owner and Contractor concerning the Work. The Contract supersedes prior negotiations, representations, or agreements, whether written or oral.

12. *Contract Documents*—Those items so designated in the Agreement. Only printed or hard copies of the items listed in the Agreement are Contract Documents. Approved Shop Drawings, other Contractor submittals, and the reports and drawings of subsurface and physical conditions are not Contract Documents.
13. *Contract Price*—The moneys payable by Owner to Contractor for completion of the Work in accordance with the Contract Documents as stated in the Agreement (subject to the provisions of Paragraph 11.03 in the case of Unit Price Work).
14. *Contract Times*—The number of days or the dates stated in the Agreement to: (i) achieve Milestones, if any; (ii) achieve Substantial Completion; and (iii) complete the Work so that it is ready for final payment as evidenced by Engineer's written recommendation of final payment.
15. *Contractor*—The individual or entity with whom Owner has entered into the Agreement.
16. *Cost of the Work*—See Paragraph 11.01 for definition.
17. *Drawings*—That part of the Contract Documents prepared or approved by Engineer which graphically shows the scope, extent, and character of the Work to be performed by Contractor. Shop Drawings and other Contractor submittals are not Drawings as so defined.
18. *Effective Date of the Agreement*—The date indicated in the Agreement on which it becomes effective, but if no such date is indicated, it means the date on which the Agreement is signed and delivered by the last of the two parties to sign and deliver.
19. *Engineer*—The individual or entity named as such in the Agreement.
20. *Field Order*—A written order issued by Engineer which requires minor changes in the Work but which does not involve a change in the Contract Price or the Contract Times.
21. *General Requirements*—~~Sections of Division 1 of the Specifications~~ The General Requirements pertain to all Sections of the specifications. (see SC-1.01.21)
22. *Hazardous Environmental Condition*—The presence at the Site of Asbestos, PCBs, Petroleum, Hazardous Waste, or Radioactive Material in such quantities or circumstances that may present a substantial danger to persons or property exposed thereto.
23. *Hazardous Waste*—The term Hazardous Waste shall have the meaning provided in Section 1004 of the Solid Waste Disposal Act (42 USC Section 6903) as amended from time to time.
24. *Laws and Regulations; Laws or Regulations*—Any and all applicable laws, rules, regulations, ordinances, codes, and orders of any and all governmental bodies, agencies, authorities, and courts having jurisdiction.
25. *Liens*—Charges, security interests, or encumbrances upon Project funds, real property, or personal property.
26. *Milestone*—A principal event specified in the Contract Documents relating to an intermediate completion date or time prior to Substantial Completion of all the Work.

27. *Notice of Award*—The written notice by Owner to the Successful Bidder stating that upon timely compliance by the Successful Bidder with the conditions precedent listed therein, Owner will sign and deliver the Agreement.
28. *Notice to Proceed*—A written notice given by Owner to Contractor fixing the date on which the Contract Times will commence to run and on which Contractor shall start to perform the Work under the Contract Documents.
29. *Owner*—The individual or entity with whom Contractor has entered into the Agreement and for whom the Work is to be performed.
30. *PCBs*—Polychlorinated biphenyls.
31. *Petroleum*—Petroleum, including crude oil or any fraction thereof which is liquid at standard conditions of temperature and pressure (60 degrees Fahrenheit and 14.7 pounds per square inch absolute), such as oil, petroleum, fuel oil, oil sludge, oil refuse, gasoline, kerosene, and oil mixed with other non-Hazardous Waste and crude oils.
32. *Progress Schedule*—A schedule, prepared and maintained by Contractor, describing the sequence and duration of the activities comprising the Contractor's plan to accomplish the Work within the Contract Times.
33. *Project*—The total construction of which the Work to be performed under the Contract Documents may be the whole, or a part.
34. *Project Manual*—The bound documentary information prepared for bidding and constructing the Work. A listing of the contents of the Project Manual, which may be bound in one or more volumes, is contained in the table(s) of contents.
35. *Radioactive Material*—Source, special nuclear, or byproduct material as defined by the Atomic Energy Act of 1954 (42 USC Section 2011 et seq.) as amended from time to time.
36. *Resident Project Representative*—The authorized representative of Engineer who may be assigned to the Site or any part thereof.
37. *Samples*—Physical examples of materials, equipment, or workmanship that are representative of some portion of the Work and which establish the standards by which such portion of the Work will be judged.
38. *Schedule of Submittals*—A schedule, prepared and maintained by Contractor, of required submittals and the time requirements to support scheduled performance of related construction activities.
39. *Schedule of Values*—A schedule, prepared and maintained by Contractor, allocating portions of the Contract Price to various portions of the Work and used as the basis for reviewing Contractor's Applications for Payment.

40. *Shop Drawings*—All drawings, diagrams, illustrations, schedules, and other data or information which are specifically prepared or assembled by or for Contractor and submitted by Contractor to illustrate some portion of the Work.
41. *Site*—Lands or areas indicated in the Contract Documents as being furnished by Owner upon which the Work is to be performed, including rights-of-way and easements for access thereto, and such other lands furnished by Owner which are designated for the use of Contractor.
42. *Specifications*—That part of the Contract Documents consisting of written requirements for materials, equipment, systems, standards and workmanship as applied to the Work, and certain administrative requirements and procedural matters applicable thereto.
43. *Subcontractor*—An individual or entity having a direct contract with Contractor or with any other Subcontractor for the performance of a part of the Work at the Site.
44. *Substantial Completion*—The time at which the Work (or a specified part thereof) has progressed to the point where, in the opinion of Engineer, the Work (or a specified part thereof) is sufficiently complete, in accordance with the Contract Documents, so that the Work (or a specified part thereof) can be utilized for the purposes for which it is intended. The terms “substantially complete” and “substantially completed” as applied to all or part of the Work refer to Substantial Completion thereof.
45. *Successful Bidder*—The Bidder submitting a responsive Bid to whom Owner makes an award.
46. *Supplementary Conditions*—That part of the Contract Documents which amends or supplements these General Conditions.
47. *Supplier*—A manufacturer, fabricator, supplier, distributor, materialman, or vendor having a direct contract with Contractor or with any Subcontractor to furnish materials or equipment to be incorporated in the Work by Contractor or Subcontractor.
48. *Underground Facilities*—All underground pipelines, conduits, ducts, cables, wires, manholes, vaults, tanks, tunnels, or other such facilities or attachments, and any encasements containing such facilities, including those that convey electricity, gases, steam, liquid petroleum products, telephone or other communications, cable television, water, wastewater, storm water, other liquids or chemicals, or traffic or other control systems.
49. *Unit Price Work*—Work to be paid for on the basis of unit prices.
50. *Work*—The entire construction or the various separately identifiable parts thereof required to be provided under the Contract Documents. Work includes and is the result of performing or providing all labor, services, and documentation necessary to produce such construction, and furnishing, installing, and incorporating all materials and equipment into such construction, all as required by the Contract Documents.
51. *Work Change Directive*—A written statement to Contractor issued on or after the Effective Date of the Agreement and signed by Owner and recommended by Engineer ordering an

addition, deletion, or revision in the Work, or responding to differing or unforeseen subsurface or physical conditions under which the Work is to be performed or to emergencies. A Work Change Directive will not change the Contract Price or the Contract Times but is evidence that the parties expect that the change ordered or documented by a Work Change Directive will be incorporated in a subsequently issued Change Order following negotiations by the parties as to its effect, if any, on the Contract Price or Contract Times.

52. Surety- The person, firm, or corporation which is bound by the contract bonds with and for Contractor (Principal); and which is held and firmly bound unto Owner for the conditions of obligations set forth in said bonds (see SC-1.01.52).

1.02 Terminology

- A. The words and terms discussed in Paragraph 1.02.B through F are not defined but, when used in the Bidding Requirements or Contract Documents, have the indicated meaning.
- B. *Intent of Certain Terms or Adjectives:*
1. The Contract Documents include the terms “as allowed,” “as approved,” “as ordered,” “as directed” or terms of like effect or import to authorize an exercise of professional judgment by Engineer. In addition, the adjectives “reasonable,” “suitable,” “acceptable,” “proper,” “satisfactory,” or adjectives of like effect or import are used to describe an action or determination of Engineer as to the Work. It is intended that such exercise of professional judgment, action, or determination will be solely to evaluate, in general, the Work for compliance with the information in the Contract Documents and with the design concept of the Project as a functioning whole as shown or indicated in the Contract Documents (unless there is a specific statement indicating otherwise). The use of any such term or adjective is not intended to and shall not be effective to assign to Engineer any duty or authority to supervise or direct the performance of the Work, or any duty or authority to undertake responsibility contrary to the provisions of Paragraph 9.09 or any other provision of the Contract Documents.
- C. *Day:*
1. The word “day” means a calendar day of 24 hours measured from midnight to the next midnight.
- D. *Defective:*
1. The word “defective,” when modifying the word “Work,” refers to Work that is unsatisfactory, faulty, or deficient in that it:
 - a. does not conform to the Contract Documents; or
 - b. does not meet the requirements of any applicable inspection, reference standard, test, or approval referred to in the Contract Documents; or

- c. has been damaged prior to Engineer's recommendation of final payment (unless responsibility for the protection thereof has been assumed by Owner at Substantial Completion in accordance with Paragraph 14.04 or 14.05).

E. Furnish, Install, Perform, Provide:

1. The word "furnish," when used in connection with services, materials, or equipment, shall mean to supply and deliver said services, materials, or equipment to the Site (or some other specified location) ready for use or installation and in usable or operable condition.
 2. The word "install," when used in connection with services, materials, or equipment, shall mean to put into use or place in final position said services, materials, or equipment complete and ready for intended use.
 3. The words "perform" or "provide," when used in connection with services, materials, or equipment, shall mean to furnish and install said services, materials, or equipment complete and ready for intended use.
 4. When "furnish," "install," "perform," or "provide" is not used in connection with services, materials, or equipment in a context clearly requiring an obligation of Contractor, "provide" is implied.
- F. Unless stated otherwise in the Contract Documents, words or phrases that have a well-known technical or construction industry or trade meaning are used in the Contract Documents in accordance with such recognized meaning.

ARTICLE 2 – PRELIMINARY MATTERS

2.01 *Delivery of Bonds and Evidence of Insurance*

- A. When Contractor delivers the executed counterparts of the Agreement to Owner, Contractor shall also deliver to Owner such bonds as Contractor may be required to furnish.
- B. *Evidence of Insurance:* Before any Work at the Site is started, Contractor and Owner shall each deliver to the other, with copies to each additional insured identified in the Supplementary Conditions, certificates of insurance (and other evidence of insurance which either of them or any additional insured may reasonably request) which Contractor and Owner respectively are required to purchase and maintain in accordance with Article 5.

2.02 *Copies of Documents*

- A. Owner shall furnish to Contractor up to ~~ten~~ five printed or hard copies of the Drawings and Project Manual. Additional copies will be furnished upon request at the cost of reproduction. (see SC-2.02.A)

2.03 *Commencement of Contract Times; Notice to Proceed*

- A. The Contract Times will commence to run on the thirtieth day after the Effective Date of the Agreement or, if a Notice to Proceed is given, on the day indicated in the Notice to Proceed. A Notice to Proceed may be given at any time within 30 days after the Effective Date of the

Agreement. In no event will the Contract Times commence to run later than the sixtieth day after the day of Bid opening or the thirtieth day after the Effective Date of the Agreement, whichever date is earlier.

2.04 *Starting the Work*

- A. Contractor shall start to perform the Work on the date when the Contract Times commence to run. No Work shall be done at the Site prior to the date on which the Contract Times commence to run.

2.05 *Before Starting Construction*

- A. Preliminary Schedules: Within 10 days after the Effective Date of the Agreement At the Preconstruction Conference (unless otherwise specified in the General Requirements), Contractor shall submit to Engineer for timely review (see SC-2.05.A):

1. a preliminary Progress Schedule indicating the times (numbers of days or dates) for starting and completing the various stages of the Work, including any Milestones specified in the Contract Documents;
2. a preliminary Schedule of Submittals; and
3. a preliminary Schedule of Values for all of the Work which includes quantities and prices of items which when added together equal the Contract Price and subdivides the Work into component parts in sufficient detail to serve as the basis for progress payments during performance of the Work. Such prices will include an appropriate amount of overhead and profit applicable to each item of Work.

- B. Before any Work at the Site is started, Contractor shall deliver to the Owner, certificates of insurance that Contractor is required to purchase and maintain in accordance with Article 5. (see SC-2.05.B)

2.06 *Preconstruction Conference; Designation of Authorized Representatives*

- A. Before any Work at the Site is started, a conference attended by Owner, Contractor, Engineer, and others as appropriate will be held to establish a working understanding among the parties as to the Work and to discuss the schedules referred to in Paragraph 2.05.A, procedures for handling Shop Drawings and other submittals, processing Applications for Payment, and maintaining required records.
- B. At this conference Owner and Contractor each shall designate, in writing, a specific individual to act as its authorized representative with respect to the services and responsibilities under the Contract. Such individuals shall have the authority to transmit instructions, receive information, render decisions relative to the Contract, and otherwise act on behalf of each respective party.
- C. Owner may issue Notice to Proceed at the Preconstruction Conference. Contractor shall begin the Work within twenty-four (24) hours of the date given in the Notice to Proceed. If the Contractor does not start the Work within fourteen (14) calendar days after this date, Owner may, at his discretion, terminate Contractor in accordance with paragraph 15.02. (see SC-2.06.C)

2.07 *Initial Acceptance of Schedules*

- A. ~~At least 10 days before submission of the first Application for Payment a conference attended by Contractor, Engineer, and others as appropriate will be held to review for acceptability to Engineer as provided below the schedules submitted in accordance with Paragraph 2.05.A. Contractor shall have an additional 10 days to make corrections and adjustments and to complete and resubmit the schedules.~~ No progress payment shall be made to Contractor until acceptable schedules are submitted to Engineer. All schedules as set forth in Article 2 shall be submitted and accepted by the Owner and engineer within 30 days of NTP. Should any schedule not be accepted within 30 days of the NTP, it will be considered a breach of contract and reason for termination of the contract for cause in accordance with the General Conditions, Section 15.02. (see SC-2.07.A)
1. The Progress Schedule will be acceptable to Engineer if it provides an orderly progression of the Work to completion within the Contract Times. Such acceptance will not impose on Engineer responsibility for the Progress Schedule, for sequencing, scheduling, or progress of the Work, nor interfere with or relieve Contractor from Contractor's full responsibility therefor.
 2. Contractor's Schedule of Submittals will be acceptable to Engineer if it provides a workable arrangement for reviewing and processing the required submittals.
 3. Contractor's Schedule of Values will be acceptable to Engineer as to form and substance if it provides a reasonable allocation of the Contract Price to component parts of the Work.

ARTICLE 3 – CONTRACT DOCUMENTS: INTENT, AMENDING, REUSE

3.01 *Intent*

- A. The Contract Documents are complementary; what is required by one is as binding as if required by all.
- B. It is the intent of the Contract Documents to describe a functionally complete project (or part thereof) to be constructed in accordance with the Contract Documents. Any labor, documentation, services, materials, or equipment that reasonably may be inferred from the Contract Documents or from prevailing custom or trade usage as being required to produce the indicated result will be provided whether or not specifically called for, at no additional cost to Owner.
- C. Clarifications and interpretations of the Contract Documents shall be issued by Engineer as provided in Article 9.

3.02 *Reference Standards*

- A. Standards, Specifications, Codes, Laws, and Regulations
 1. Reference to standards, specifications, manuals, or codes of any technical society, organization, or association, or to Laws or Regulations, whether such reference be specific or by implication, shall mean the standard, specification, manual, code, or Laws or Regulations

in effect at the time of opening of Bids (or on the Effective Date of the Agreement if there were no Bids), except as may be otherwise specifically stated in the Contract Documents.

2. No provision of any such standard, specification, manual, or code, or any instruction of a Supplier, shall be effective to change the duties or responsibilities of Owner, Contractor, or Engineer, or any of their subcontractors, consultants, agents, or employees, from those set forth in the Contract Documents. No such provision or instruction shall be effective to assign to Owner, Engineer, or any of their officers, directors, members, partners, employees, agents, consultants, or subcontractors, any duty or authority to supervise or direct the performance of the Work or any duty or authority to undertake responsibility inconsistent with the provisions of the Contract Documents.

3.03 *Reporting and Resolving Discrepancies*

A. *Reporting Discrepancies:*

1. *Contractor's Review of Contract Documents Before Starting Work:* Before undertaking each part of the Work, Contractor shall carefully study and compare the Contract Documents and check and verify pertinent figures therein and all applicable field measurements. Contractor shall promptly report in writing to Engineer any conflict, error, ambiguity, or discrepancy which Contractor discovers, or has actual knowledge of, and shall obtain a written interpretation or clarification from Engineer before proceeding with any Work affected thereby.
2. *Contractor's Review of Contract Documents During Performance of Work:* If, during the performance of the Work, Contractor discovers any conflict, error, ambiguity, or discrepancy within the Contract Documents, or between the Contract Documents and (a) any applicable Law or Regulation, (b) any standard, specification, manual, or code, or (c) any instruction of any Supplier, then Contractor shall promptly report it to Engineer in writing. Contractor shall not proceed with the Work affected thereby (except in an emergency as required by Paragraph 6.16.A) until an amendment or supplement to the Contract Documents has been issued by one of the methods indicated in Paragraph 3.04.
3. Contractor shall not be liable to Owner or Engineer for failure to report any conflict, error, ambiguity, or discrepancy in the Contract Documents unless Contractor had actual knowledge thereof.

B. *Resolving Discrepancies:*

1. Except as may be otherwise specifically stated in the Contract Documents, the provisions of the Contract Documents shall take precedence in resolving any conflict, error, ambiguity, or discrepancy between the provisions of the Contract Documents and:
 - a. the provisions of any standard, specification, manual, or code, or the instruction of any Supplier (whether or not specifically incorporated by reference in the Contract Documents); or

- b. the provisions of any Laws or Regulations applicable to the performance of the Work (unless such an interpretation of the provisions of the Contract Documents would result in violation of such Law or Regulation).

3.04 *Amending and Supplementing Contract Documents*

- A. The Contract Documents may be amended ~~to provide for additions, deletions, and revisions in the Work or to modify the terms and conditions thereof by either a Change Order or a Work Change Directive as outlined in the Florida Department of Transportation (FDOT) Supplemental Lap Specifications.~~
- B. The requirements of the Contract Documents may be supplemented, and ~~minor~~ variations and deviations in the Work may be authorized, ~~by one or more of the following ways:~~ pursuant to the Florida Department of Transportation (FDOT) Supplemental Lap Specifications.
 - ~~1. A Field Order;~~
 - ~~2. Engineer's approval of a Shop Drawing or Sample (subject to the provisions of Paragraph 6.17.D.3); or~~
 - ~~3. Engineer's written interpretation or clarification.~~

3.05 *Reuse of Documents*

- A. Contractor and any Subcontractor or Supplier shall not:
 1. have or acquire any title to or ownership rights in any of the Drawings, Specifications, or other documents (or copies of any thereof) prepared by or bearing the seal of Engineer or its consultants, including electronic media editions; or
 2. reuse any such Drawings, Specifications, other documents, or copies thereof on extensions of the Project or any other project without written consent of Owner and Engineer and specific written verification or adaptation by Engineer.
- B. The prohibitions of this Paragraph 3.05 will survive final payment, or termination of the Contract. Nothing herein shall preclude Contractor from retaining copies of the Contract Documents for record purposes.

3.06 *Electronic Data*

- A. Unless otherwise stated in the Supplementary Conditions, the data furnished by Owner or Engineer to Contractor, or by Contractor to Owner or Engineer, that may be relied upon are limited to the printed copies (also known as hard copies). Files in electronic media format of text, data, graphics, or other types are furnished only for the convenience of the receiving party. Any conclusion or information obtained or derived from such electronic files will be at the user's sole risk. If there is a discrepancy between the electronic files and the hard copies, the hard copies govern.
- B. Because data stored in electronic media format can deteriorate or be modified inadvertently or otherwise without authorization of the data's creator, the party receiving electronic files agrees that it will perform acceptance tests or procedures within 60 days, after which the receiving party

shall be deemed to have accepted the data thus transferred. Any errors detected within the 60-day acceptance period will be corrected by the transferring party.

- C. When transferring documents in electronic media format, the transferring party makes no representations as to long term compatibility, usability, or readability of documents resulting from the use of software application packages, operating systems, or computer hardware differing from those used by the data's creator.

ARTICLE 4 – AVAILABILITY OF LANDS; SUBSURFACE AND PHYSICAL CONDITIONS; HAZARDOUS ENVIRONMENTAL CONDITIONS; REFERENCE POINTS

4.01 Availability of Lands

- A. Owner shall furnish the Site. Owner shall notify Contractor of any encumbrances or restrictions not of general application but specifically related to use of the Site with which Contractor must comply in performing the Work. Owner will obtain in a timely manner and pay for easements for permanent structures or permanent changes in existing facilities. If Contractor and Owner are unable to agree on entitlement to or on the amount or extent, if any, of any adjustment in the Contract Price or Contract Times, or both, as a result of any delay in Owner's furnishing the Site or a part thereof, Contractor may make a Claim therefor as provided in Paragraph 10.05.
- B. Upon reasonable written request, Owner shall furnish Contractor with a current statement of record legal title and legal description of the lands upon which the Work is to be performed and Owner's interest therein as necessary for giving notice of or filing a mechanic's or construction lien against such lands in accordance with applicable Laws and Regulations.
- C. Contractor shall provide for all additional lands and access thereto that may be required for temporary construction facilities or storage of materials and equipment. Contractor shall obtain said land rights at his own expense and without liability to the Owner. Contractor shall not enter upon private property without first obtaining written permission from the rightful property owner (see SC-4.01.C)

4.02 Subsurface and Physical Conditions

- A. *Reports and Drawings:* The Supplementary Conditions identify:
1. those reports known to Owner of explorations and tests of subsurface conditions at or contiguous to the Site; and
 2. those drawings known to Owner of physical conditions relating to existing surface or subsurface structures at the Site (except Underground Facilities).
- B. *Limited Reliance by Contractor on Technical Data Authorized:* Contractor may rely upon the accuracy of the "technical data" contained in such reports and drawings, but such reports and drawings are not Contract Documents. Such "technical data" is identified in the Supplementary Conditions. Except for such reliance on such "technical data," Contractor may not rely upon or make any claim against Owner or Engineer, or any of their officers, directors, members, partners, employees, agents, consultants, or subcontractors with respect to:

1. the completeness of such reports and drawings for Contractor's purposes, including, but not limited to, any aspects of the means, methods, techniques, sequences, and procedures of construction to be employed by Contractor, and safety precautions and programs incident thereto; or
 2. other data, interpretations, opinions, and information contained in such reports or shown or indicated in such drawings; or
 3. any Contractor interpretation of or conclusion drawn from any "technical data" or any such other data, interpretations, opinions, or information.
- C. In the preparation of Drawings and Specifications, Engineer or Engineer's Consultant relied upon the following reports(s) of explorations and tests of subsurface conditions at the site: Appendix E. (see SC-4.02.C)

4.03 Differing Subsurface or Physical Conditions

- A. *Notice:* If Contractor believes that any subsurface or physical condition that is uncovered or revealed either:
1. is of such a nature as to establish that any "technical data" on which Contractor is entitled to rely as provided in Paragraph 4.02 is materially inaccurate; or
 2. is of such a nature as to require a change in the Contract Documents; or
 3. differs materially from that shown or indicated in the Contract Documents; or
 4. is of an unusual nature, and differs materially from conditions ordinarily encountered and generally recognized as inherent in work of the character provided for in the Contract Documents;

~~then Contractor shall, promptly after becoming aware thereof and before further disturbing the subsurface or physical conditions or performing any Work in connection therewith (except in an emergency as required by Paragraph 6.16.A), notify Owner and Engineer in writing about such condition. Contractor shall not further disturb such condition or perform any Work in connection therewith (except as aforesaid) until receipt of written order to do so refer to the procedures outlined in the Florida Department of Transportation (FDOT) Supplemental LAP Specifications.~~

- B. *Engineer's Review:* After receipt of written notice as required by Paragraph 4.03.A, Engineer will promptly review the pertinent condition, determine the necessity of Owner's obtaining additional exploration or tests with respect thereto, and advise Owner in writing (with a copy to Contractor) of Engineer's findings and conclusions.

C. *Possible Price and Times Adjustments:*

1. The Contract Price or the Contract Times, or both, will be equitably adjusted to the extent that the existence of such differing subsurface or physical condition causes an increase or decrease in Contractor's cost of, or time required for, performance of the Work; subject, however, to the following:

- a. such condition must meet any one or more of the categories described in Paragraph 4.03.A; and
 - b. with respect to Work that is paid for on a unit price basis, any adjustment in Contract Price will be subject to the provisions of Paragraphs 9.07 and 11.03.
2. Contractor shall not be entitled to any adjustment in the Contract Price or Contract Times if:
- a. Contractor knew of the existence of such conditions at the time Contractor made a final commitment to Owner with respect to Contract Price and Contract Times by the submission of a Bid or becoming bound under a negotiated contract; or
 - b. the existence of such condition could reasonably have been discovered or revealed as a result of any examination, investigation, exploration, test, or study of the Site and contiguous areas required by the Bidding Requirements or Contract Documents to be conducted by or for Contractor prior to Contractor's making such final commitment; or
 - c. Contractor failed to give the written notice as required by Paragraph 4.03.A.
3. If Owner and Contractor are unable to agree on entitlement to or on the amount or extent, if any, of any adjustment in the Contract Price or Contract Times, or both, a Claim may be made therefor as provided in Paragraph 10.05. However, ~~neither Owner, or Engineer, or any of their officers, directors, members, partners, employees, agents, consultants, or subcontractors and Engineer's Consultants~~ shall not be liable to Contractor for any claims, costs, losses, or damages (including but not limited to all fees and charges of engineers, architects, attorneys, and other professionals and all court ~~or arbitration~~ or other dispute resolution costs) sustained by Contractor on or in connection with any other project or anticipated project. (see SC-4.03.C.3)

4.04 *Underground Facilities*

- A. *Shown or Indicated:* The information and data shown or indicated in the Contract Documents with respect to existing Underground Facilities at or contiguous to the Site is based on information and data furnished to Owner or Engineer by the owners of such Underground Facilities, including Owner, or by others. Unless it is otherwise expressly provided in the Supplementary Conditions:
1. Owner and Engineer shall not be responsible for the accuracy or completeness of any such information or data provided by others; and
 2. the cost of all of the following will be included in the Contract Price, and Contractor shall have full responsibility for:
 - a. reviewing and checking all such information and data;
 - b. locating all Underground Facilities shown or indicated in the Contract Documents;
 - c. coordination of the Work with the owners of such Underground Facilities, including Owner, during construction; and

- d. the safety and protection of all such Underground Facilities and repairing any damage thereto resulting from the Work.

B. Not Shown or Indicated:

1. If an Underground Facility is uncovered or revealed at or contiguous to the Site which was not shown or indicated, or not shown or indicated with reasonable accuracy in the Contract Documents, Contractor shall, promptly after becoming aware thereof and before further disturbing conditions affected thereby or performing any Work in connection therewith (except in an emergency as required by Paragraph 6.16.A), identify the owner of such Underground Facility and give written notice to that owner and to Owner and Engineer. Engineer will promptly review the Underground Facility and determine the extent, if any, to which a change is required in the Contract Documents to reflect and document the consequences of the existence or location of the Underground Facility. During such time, Contractor shall be responsible for the safety and protection of such Underground Facility.
2. If Engineer concludes that a change in the Contract Documents is required, a Work Change Directive or a Change Order will be issued to reflect and document such consequences. An equitable adjustment shall be made in the Contract Price or Contract Times, or both, to the extent that they are attributable to the existence or location of any Underground Facility that was not shown or indicated or not shown or indicated with reasonable accuracy in the Contract Documents and that Contractor did not know of and could not reasonably have been expected to be aware of or to have anticipated. If Owner and Contractor are unable to agree on entitlement to or on the amount or extent, if any, of any such adjustment in Contract Price or Contract Times, Owner or Contractor may make a Claim therefor as provided in Paragraph 10.05.

4.05 Reference Points

- A. Owner shall provide engineering surveys to establish reference points for construction which in Engineer's judgment are necessary to enable Contractor to proceed with the Work. Contractor shall be responsible for laying out the Work, shall protect and preserve the established reference points and property monuments, and shall make no changes or relocations without the prior written approval of Owner. Contractor shall report to Engineer whenever any reference point or property monument is lost or destroyed or requires relocation because of necessary changes in grades or locations, and shall be responsible for the accurate replacement or relocation of such reference points or property monuments by professionally qualified personnel.

4.06 Hazardous Environmental Condition at Site

- A. *Reports and Drawings:* The Supplementary Conditions identify those reports and drawings known to Owner relating to Hazardous Environmental Conditions that have been identified at the Site.
- B. *Limited Reliance by Contractor on Technical Data Authorized:* Contractor may rely upon the accuracy of the "technical data" contained in such reports and drawings, but such reports and drawings are not Contract Documents. Such "technical data" is identified in the Supplementary Conditions. Except for such reliance on such "technical data," Contractor may not rely upon or

make any claim against Owner or Engineer, or any of their officers, directors, members, partners, employees, agents, consultants, or subcontractors with respect to:

1. the completeness of such reports and drawings for Contractor's purposes, including, but not limited to, any aspects of the means, methods, techniques, sequences and procedures of construction to be employed by Contractor and safety precautions and programs incident thereto; or
 2. other data, interpretations, opinions and information contained in such reports or shown or indicated in such drawings; or
 3. any Contractor interpretation of or conclusion drawn from any "technical data" or any such other data, interpretations, opinions or information.
- C. Contractor shall not be responsible for any Hazardous Environmental Condition uncovered or revealed at the Site which was not shown or indicated in Drawings or Specifications or identified in the Contract Documents to be within the scope of the Work. Contractor shall be responsible for a Hazardous Environmental Condition created with any materials brought to the Site by Contractor, Subcontractors, Suppliers, or anyone else for whom Contractor is responsible.
- D. If Contractor encounters a Hazardous Environmental Condition or if Contractor or anyone for whom Contractor is responsible creates a Hazardous Environmental Condition, Contractor shall immediately: (i) secure or otherwise isolate such condition; (ii) stop all Work in connection with such condition and in any area affected thereby (except in an emergency as required by Paragraph 6.16.A); and (iii) notify Owner and Engineer (and promptly thereafter confirm such notice in writing). Owner shall promptly consult with Engineer concerning the necessity for Owner to retain a qualified expert to evaluate such condition or take corrective action, if any. Promptly after consulting with Engineer, Owner shall take such actions as are necessary to permit Owner to timely obtain required permits and provide Contractor the written notice required by Paragraph 4.06.E.
- E. Contractor shall not be required to resume Work in connection with such condition or in any affected area until after Owner has obtained any required permits related thereto and delivered written notice to Contractor: (i) specifying that such condition and any affected area is or has been rendered safe for the resumption of Work; or (ii) specifying any special conditions under which such Work may be resumed safely. If Owner and Contractor cannot agree as to entitlement to or on the amount or extent, if any, of any adjustment in Contract Price or Contract Times, or both, as a result of such Work stoppage or such special conditions under which Work is agreed to be resumed by Contractor, either party may make a Claim therefor as provided in Paragraph 10.05.
- F. If after receipt of such written notice Contractor does not agree to resume such Work based on a reasonable belief it is unsafe, or does not agree to resume such Work under such special conditions, then Owner may order the portion of the Work that is in the area affected by such condition to be deleted from the Work. If Owner and Contractor cannot agree as to entitlement to or on the amount or extent, if any, of an adjustment in Contract Price or Contract Times as a result of deleting such portion of the Work, then either party may make a Claim therefor as provided in Paragraph 10.05. Owner may have such deleted portion of the Work performed by Owner's own forces or others in accordance with Article 7.

- G. To the fullest extent permitted by Laws and Regulations, Owner shall indemnify and hold harmless Contractor, Subcontractors, and Engineer, and the officers, directors, members, partners, employees, agents, consultants, and subcontractors of each and any of them from and against all claims, costs, losses, and damages (including but not limited to all fees and charges of engineers, architects, attorneys, and other professionals and all court or arbitration or other dispute resolution costs) arising out of or relating to a Hazardous Environmental Condition, provided that such Hazardous Environmental Condition: (i) was not shown or indicated in the Drawings or Specifications or identified in the Contract Documents to be included within the scope of the Work, and (ii) was not created by Contractor or by anyone for whom Contractor is responsible. Nothing in this Paragraph 4.06.G shall obligate Owner to indemnify any individual or entity from and against the consequences of that individual's or entity's own negligence.
- H. To the fullest extent permitted by Laws and Regulations, Contractor shall indemnify and hold harmless Owner and Engineer, and the officers, directors, members, partners, employees, agents, consultants, and subcontractors of each and any of them from and against all claims, costs, losses, and damages (including but not limited to all fees and charges of engineers, architects, attorneys, and other professionals and all court or arbitration or other dispute resolution costs) arising out of or relating to a Hazardous Environmental Condition created by Contractor or by anyone for whom Contractor is responsible. Nothing in this Paragraph 4.06.H shall obligate Contractor to indemnify any individual or entity from and against the consequences of that individual's or entity's own negligence.
- I. The provisions of Paragraphs 4.02, 4.03, and 4.04 do not apply to a Hazardous Environmental Condition uncovered or revealed at the Site.

ARTICLE 5 – BONDS AND INSURANCE

5.01 *Performance, Payment, and Other Bonds*

- A. Contractor shall furnish performance and payment bonds, each in an amount at least equal to the Contract Price as security for the faithful performance and payment of all of Contractor's obligations under the Contract Documents. These bonds shall remain in effect until one year after the date when final payment becomes due or until completion of the correction period specified in Paragraph 13.07, whichever is later, except as provided otherwise by Laws or Regulations or by the Contract Documents. Contractor shall also furnish such other bonds as are required by the Contract Documents.
- B. ~~All bonds shall be in the form prescribed by the Contract Documents except as provided otherwise by Laws or Regulations, and shall be executed by such sureties as are named in the list of "Companies Holding Certificates of Authority as Acceptable Sureties on Federal Bonds and as Acceptable Reinsuring Companies" as published in Circular 570 (amended) by the Financial Management Service, Surety Bond Branch, U.S. Department of the Treasury. All bonds signed by an agent or attorney in fact must be accompanied by a certified copy of that individual's authority to bind the surety. The evidence of authority shall show that it is effective on the date the agent or attorney in fact signed each bond. All Bonds shall be in the form prescribed by the contract Documents or other form approved by Owner. All else notwithstanding, the terms of all Bonds shall be substantially in the form prescribed by Chapter 255, Florida Statutes. All Bonds shall be executed by Contractor and a corporate bonding company licensed to transact such business in the State of Florida and named on the current list of "Surety Companies Acceptable~~

on Federal Bonds” as published in the Treasury Department Circular Number 570. Contractor will cause the Bonds to be recorded with the Clerk of the Circuit Court in the county in which the Work is to be performed. Failure to execute bonds in the form prescribed may constitute non-responsiveness on the part of the Contractor. The expense for all Bonds shall be the Contractor’s responsibility. (see SC-5.01.B)

- C. If the surety on any bond furnished by Contractor is declared bankrupt or becomes insolvent or its right to do business is terminated in any state where any part of the Project is located or it ceases to meet the requirements of Paragraph 5.01.B, Contractor shall promptly notify Owner and Engineer and shall, within 20 days after the event giving rise to such notification, provide another bond and surety, both of which shall comply with the requirements of Paragraphs 5.01.B and 5.02.

5.02 *Licensed Sureties and Insurers*

- A. All bonds and insurance required by the Contract Documents to be purchased and maintained by Owner or Contractor shall be obtained from surety or insurance companies that are duly licensed or authorized in the jurisdiction in which the Project is located to issue bonds or insurance policies for the limits and coverages so required. Such surety and insurance companies shall also meet such additional requirements and qualifications as may be provided in the Supplementary Conditions. Certificates of insurance shall be issued by a company with a Best’s rating of at least B+ authorized to do business in the State of Florida. Owner must approve non-rated insurers. If used, Owner shall be shown as Certificate Holder, Engineer as Additional Insured and provide a 30-day cancellation notice.

5.03 *Certificates of Insurance*

- A. Contractor shall deliver to Owner, with copies to each additional insured and loss payee identified in the Supplementary Conditions, certificates of insurance (and other evidence of insurance requested by Owner or any other additional insured) which Contractor is required to purchase and maintain.
- B. ~~Owner shall deliver to Contractor, with copies to each additional insured and loss payee identified in the Supplementary Conditions, certificates of insurance (and other evidence of insurance requested by Contractor or any other additional insured) which Owner is required to purchase and maintain. Insurance policies written on a “Claims Made” form is not acceptable without Owner’s approval. (see SC-5.03.B)~~
- C. Failure of Owner to demand such certificates or other evidence of Contractor's full compliance with these insurance requirements or failure of Owner to identify a deficiency in compliance from the evidence provided shall not be construed as a waiver of Contractor’s obligation to maintain such insurance.
- D. Owner does not represent that insurance coverage and limits established in this Contract necessarily will be adequate to protect Contractor.
- E. The insurance and insurance limits required herein shall not be deemed as a limitation on Contractor’s liability under the indemnities granted to Owner in the Contract Documents.

- F. Umbrella Liability insurance is preferred, but an Excess Liability equivalent is acceptable. Whichever type of coverage is provided, it shall not be more restrictive than the underlying insurance policy coverages, including, but not limited to the coverage Trigger, defense, notice of occurrence/accident/circumstances, notice of claim and extended reporting period. (see SC-5.03.F)
- G. No work shall commence under this contract until the required Certificate(s) have been provided. Work shall not continue after expiration (or cancellation) until new Certificate(s) have been provided. Non-continuance of work after expiration (or cancellation) of Certificate(s) will not constitute a delay beyond Contractor's control as defined in paragraph 12.03. (see SC- 5.03.G)
- H. Contractor shall arrange for its insurers' policies to include, or be endorsed to include, a severability or interest/cross liability provision, so that Owner will be treated as if a separate policy were in existence, but without increasing the policy limits. (see SC-5.03.H)
- I. Contractor's deductibles/self-insured retentions shall be disclosed to Owner and may be disapproved by the latter. They shall be reduced or eliminated at the option of Owner. Contractor is responsible for the amount of any deductible or self-insured retention. (see SC- 6.03.I)
- J. These insurance requirements shall not relieve or limit the liability of Contractor. Owner does not in any way represent that these types or amounts of insurance are sufficient or adequate to protect Contractor's interests or liabilities, but are merely minimums. (see SC-5.03.J)
- K. Insurance required of Contractor or any other insurance of Contractor shall be considered primary, and insurance or self-insurance of Owner shall be considered excess, as may be applicable to claims that arise out of this contract. (see SC-5.03.K)
- L. Receipt of Certificates or other documentation of insurance or policies or copies of policies by Owner, or by any of its representatives, which indicate less coverage than required does not constitute a waiver of the Contractor's obligation to fulfill the insurance requirements herein. (see SC-5.03.L)
- M. The Contractor shall either (a) require each subcontractor to produce and maintain the same coverage as required of the Contractor, or (b) insure the activities of subcontractors in his own policy. (see SC-5.03.M)
- N. These insurance requirements are minimums and may not be adequate to cover Contractor exposures. (see SC-5.03.N)

5.04 Contractor's Insurance

- A. Contractor shall purchase and maintain such insurance as is appropriate for the Work being performed and as will provide protection from claims set forth below which may arise out of or result from Contractor's performance of the Work and Contractor's other obligations under the Contract Documents, whether it is to be performed by Contractor, any Subcontractor or Supplier, or by anyone directly or indirectly employed by any of them to perform any of the Work, or by anyone for whose acts any of them may be liable:

1. claims under workers' compensation, disability benefits, and other similar employee benefit acts;
 2. claims for damages because of bodily injury, occupational sickness or disease, or death of Contractor's employees;
 3. claims for damages because of bodily injury, sickness or disease, or death of any person other than Contractor's employees;
 4. claims for damages insured by reasonably available personal injury liability coverage which are sustained:
 - a. by any person as a result of an offense directly or indirectly related to the employment of such person by Contractor, or
 - b. by any other person for any other reason;
 5. claims for damages, other than to the Work itself, because of injury to or destruction of tangible property wherever located, including loss of use resulting therefrom; and
 6. claims for damages because of bodily injury or death of any person or property damage arising out of the ownership, maintenance or use of any motor vehicle.
- B. The policies of insurance required by this Paragraph 5.04 shall:
1. with respect to insurance required by Paragraphs 5.04.A.3 through 5.04.A.6 inclusive, be written on an occurrence basis, include as additional insureds (subject to any customary exclusion regarding professional liability) Owner and Engineer, and any other individuals or entities identified in the Supplementary Conditions, all of whom shall be listed as additional insureds, and include coverage for the respective officers, directors, members, partners, employees, agents, consultants, and subcontractors of each and any of all such additional insureds, and the insurance afforded to these additional insureds shall provide primary coverage for all claims covered thereby;
 2. include at least the specific coverages and be written for not less than the limits of liability provided in the Supplementary Conditions or required by Laws or Regulations, whichever is greater;
 3. include contractual liability insurance covering Contractor's indemnity obligations under Paragraphs 6.11 and 6.20;
 4. contain a provision or endorsement that the coverage afforded will not be canceled, materially changed or renewal refused until at least 30 days prior written notice has been given to Owner and Contractor and to each other additional insured identified in the Supplementary Conditions to whom a certificate of insurance has been issued (and the certificates of insurance furnished by the Contractor pursuant to Paragraph 5.03 will so provide);

5. remain in effect at least until final payment and at all times thereafter when Contractor may be correcting, removing, or replacing defective Work in accordance with Paragraph 13.07; and
 6. include completed operations coverage:
 - a. Such insurance shall remain in effect for two years after final payment.
 - b. Contractor shall furnish Owner and each other additional insured identified in the Supplementary Conditions, to whom a certificate of insurance has been issued, evidence satisfactory to Owner and any such additional insured of continuation of such insurance at final payment and one year thereafter.
- C. The limits of liability for the insurance required by paragraph 5.04 of the General Conditions shall provide coverage for not less than the amounts shown in Exhibit 1 of the contract documents, or greater where required by Laws and Regulations. (see SC-5.04.C)

5.05 *Owner's Liability Insurance*

- A. In addition to the insurance required to be provided by Contractor under Paragraph 5.04, Owner, at Owner's option, may purchase and maintain at Owner's expense Owner's own liability insurance as will protect Owner against claims which may arise from operations under the Contract Documents.

5.06 *Property Insurance*

- A. ~~Unless otherwise provided in the Supplementary Conditions, Owner shall purchase and maintain property insurance upon the Work at the Site in the amount of the full replacement cost thereof (subject to such deductible amounts as may be provided in the Supplementary Conditions or required by Laws and Regulations). This insurance shall:~~
 1. ~~include the interests of Owner, Contractor, Subcontractors, and Engineer, and any other individuals or entities identified in the Supplementary Conditions, and the officers, directors, members, partners, employees, agents, consultants, and subcontractors of each and any of them, each of whom is deemed to have an insurable interest and shall be listed as a loss payee;~~
 2. ~~be written on a Builder's Risk "all-risk" policy form that shall at least include insurance for physical loss or damage to the Work, temporary buildings, falsework, and materials and equipment in transit, and shall insure against at least the following perils or causes of loss: fire, lightning, extended coverage, theft, vandalism and malicious mischief, earthquake, collapse, debris removal, demolition occasioned by enforcement of Laws and Regulations, water damage (other than that caused by flood), and such other perils or causes of loss as may be specifically required by the Supplementary Conditions.~~
 3. ~~include expenses incurred in the repair or replacement of any insured property (including but not limited to fees and charges of engineers and architects);~~

- ~~4. cover materials and equipment stored at the Site or at another location that was agreed to in writing by Owner prior to being incorporated in the Work, provided that such materials and equipment have been included in an Application for Payment recommended by Engineer;~~
 - ~~5. allow for partial utilization of the Work by Owner;~~
 - ~~6. include testing and startup; and~~
 - ~~7. be maintained in effect until final payment is made unless otherwise agreed to in writing by Owner, Contractor, and Engineer with 30 days written notice to each other loss payee to whom a certificate of insurance has been issued.~~
- B. ~~Owner shall purchase and maintain such equipment breakdown insurance or additional property insurance as may be required by the Supplementary Conditions or Laws and Regulations which will include the interests of Owner, Contractor, Subcontractors, and Engineer, and any other individuals or entities identified in the Supplementary Conditions, and the officers, directors, members, partners, employees, agents, consultants and subcontractors of each and any of them, each of whom is deemed to have an insurable interest and shall be listed as a loss payee.~~
- C. ~~All the policies of insurance (and the certificates or other evidence thereof) required to be purchased and maintained in accordance with this Paragraph 5.06 will contain a provision or endorsement that the coverage afforded will not be canceled or materially changed or renewal refused until at least 30 days prior written notice has been given to Owner and Contractor and to each other loss payee to whom a certificate of insurance has been issued and will contain waiver provisions in accordance with Paragraph 5.07.~~
- D. ~~Owner shall not be responsible for purchasing and maintaining any property insurance specified in this Paragraph 5.06 to protect the interests of Contractor, Subcontractors, or others in the Work to the extent of any deductible amounts that are identified in the Supplementary Conditions. The risk of loss within such identified deductible amount will be borne by Contractor, Subcontractors, or others suffering any such loss, and if any of them wishes property insurance coverage within the limits of such amounts, each may purchase and maintain it at the purchaser's own expense.~~
- E. ~~If Contractor requests in writing that other special insurance be included in the property insurance policies provided under this Paragraph 5.06, Owner shall, if possible, include such insurance, and the cost thereof will be charged to Contractor by appropriate Change Order. Prior to commencement of the Work at the Site, Owner shall in writing advise Contractor whether or not such other insurance has been procured by Owner.~~

5.07 *Waiver of Rights*

- A. ~~Owner and Contractor intend that all policies purchased in accordance with Paragraph 5.06 will protect Owner, Contractor, Subcontractors, and Engineer, and all other individuals or entities identified in the Supplementary Conditions as loss payees (and the officers, directors, members, partners, employees, agents, consultants, and subcontractors of each and any of them) in such policies and will provide primary coverage for all losses and damages caused by the perils or causes of loss covered thereby. All such policies shall contain provisions to the effect that in the event of payment of any loss or damage the insurers will have no rights of recovery against any~~

~~of the insureds or loss payees thereunder. Owner and Contractor waive all rights against each other and their respective officers, directors, members, partners, employees, agents, consultants and subcontractors of each and any of them for all losses and damages caused by, arising out of or resulting from any of the perils or causes of loss covered by such policies and any other property insurance applicable to the Work; and, in addition, waive all such rights against Subcontractors and Engineer, and all other individuals or entities identified in the Supplementary Conditions as loss payees (and the officers, directors, members, partners, employees, agents, consultants, and subcontractors of each and any of them) under such policies for losses and damages so caused. None of the above waivers shall extend to the rights that any party making such waiver may have to the proceeds of insurance held by Owner as trustee or otherwise payable under any policy so issued.~~

- ~~B. Owner waives all rights against Contractor, Subcontractors, and Engineer, and the officers, directors, members, partners, employees, agents, consultants and subcontractors of each and any of them for:~~
- ~~1. loss due to business interruption, loss of use, or other consequential loss extending beyond direct physical loss or damage to Owner's property or the Work caused by, arising out of, or resulting from fire or other perils whether or not insured by Owner; and~~
 - ~~2. loss or damage to the completed Project or part thereof caused by, arising out of, or resulting from fire or other insured peril or cause of loss covered by any property insurance maintained on the completed Project or part thereof by Owner during partial utilization pursuant to Paragraph 14.05, after Substantial Completion pursuant to Paragraph 14.04, or after final payment pursuant to Paragraph 14.07.~~
- ~~C. Any insurance policy maintained by Owner covering any loss, damage or consequential loss referred to in Paragraph 5.07.B shall contain provisions to the effect that in the event of payment of any such loss, damage, or consequential loss, the insurers will have no rights of recovery against Contractor, Subcontractors, or Engineer, and the officers, directors, members, partners, employees, agents, consultants and subcontractors of each and any of them.~~

5.08 Receipt and Application of Insurance Proceeds

- ~~A. Any insured loss under the policies of insurance required by Paragraph 5.06 will be adjusted with Owner and made payable to Owner as fiduciary for the loss payees, as their interests may appear, subject to the requirements of any applicable mortgage clause and of Paragraph 5.08.B. Owner shall deposit in a separate account any money so received and shall distribute it in accordance with such agreement as the parties in interest may reach. If no other special agreement is reached, the damaged Work shall be repaired or replaced, the moneys so received applied on account thereof, and the Work and the cost thereof covered by an appropriate Change Order.~~
- ~~B. Owner as fiduciary shall have power to adjust and settle any loss with the insurers unless one of the parties in interest shall object in writing within 15 days after the occurrence of loss to Owner's exercise of this power. If such objection be made, Owner as fiduciary shall make settlement with the insurers in accordance with such agreement as the parties in interest may reach. If no such agreement among the parties in interest is reached, Owner as fiduciary shall~~

~~adjust and settle the loss with the insurers and, if required in writing by any party in interest, Owner as fiduciary shall give bond for the proper performance of such duties.~~

5.09 *Acceptance of Bonds and Insurance; Option to Replace*

- A. ~~If either Owner or Contractor has any objection to the coverage afforded by or other provisions of the bonds or insurance required to be purchased and maintained by the other party in accordance with Article 5 on the basis of non-conformance with the Contract Documents, the objecting party shall so notify the other party in writing within 10 days after receipt of the certificates (or other evidence requested) required by Paragraph 2.01.B. Owner and Contractor shall each provide to the other such additional information in respect of insurance provided as the other may reasonably request. If either party does not purchase or maintain all of the bonds and insurance required of such party by the Contract Documents, such party shall notify the other party in writing of such failure to purchase prior to the start of the Work, or of such failure to maintain prior to any change in the required coverage. Without prejudice to any other right or remedy, the other party may elect to obtain equivalent bonds or insurance to protect such other party's interests at the expense of the party who was required to provide such coverage, and a Change Order shall be issued to adjust the Contract Price accordingly. If Owner has any objection to the coverage afforded by or other provisions of Bonds or insurance required to be purchased and maintained by Contractor in accordance with Article 5 on the basis of non-conformance with the Contract Documents, Owner shall so notify Contractor in writing within ten days after receipt of the certificates (or other evidence requested) required by paragraph 2.05.C. Contractor shall provide to Owner such additional information in respect of insurance provided as Owner may reasonably request. (see SC-5.09.A)~~

5.10 *Partial Utilization, Acknowledgment of Property Insurer*

- A. ~~If Owner finds it necessary to occupy or use a portion or portions of the Work prior to Substantial Completion of all the Work as provided in Paragraph 14.05, no such use or occupancy shall commence before the insurers providing the property insurance pursuant to Paragraph 5.06 have acknowledged notice thereof and in writing effected any changes in coverage necessitated thereby. The insurers providing the property insurance shall consent by endorsement on the policy or policies, but the property insurance shall not be canceled or permitted to lapse on account of any such partial use or occupancy.~~

ARTICLE 6 – CONTRACTOR'S RESPONSIBILITIES

6.01 *Supervision and Superintendence*

- A. Contractor shall supervise, inspect, and direct the Work competently and efficiently, devoting such attention thereto and applying such skills and expertise as may be necessary to perform the Work in accordance with the Contract Documents. Contractor shall be solely responsible for the means, methods, techniques, sequences, and procedures of construction. Contractor shall not be responsible for the negligence of Owner or Engineer in the design or specification of a specific means, method, technique, sequence, or procedure of construction which is shown or indicated in and expressly required by the Contract Documents. Owner reserves the right to reject any means, methods, techniques, sequences or procedures proposed by Contractor which:

1. will constitute or create a hazard to the Work or to the persons or damage to property or existing utilities; or
2. will not produce finished work in accordance with the terms of the contract Documents.

Owner's failure to exercise his right to reject such means, methods, techniques, sequences or procedures shall not relieve the Contractor of his obligation to accomplish the result intended in the Contract Documents nor shall the exercise of such right create a cause of action for damages. (see SC-6.01.A)

- B. At all times during the progress of the Work, Contractor shall assign a competent resident superintendent who shall not be replaced without written notice to Owner and Engineer except under extraordinary circumstances.

6.02 *Labor; Working Hours*

- A. Contractor shall provide competent, suitably qualified personnel to survey and lay out the Work and perform construction as required by the Contract Documents. Contractor shall at all times maintain good discipline and order at the Site.
- B. Except as otherwise required for the safety or protection of persons or the Work or property at the Site or adjacent thereto, and except as otherwise stated in the Contract Documents, all Work at the Site shall be performed during regular working hours. Contractor will not permit the performance of Work on a Saturday, Sunday, or any legal holiday without Owner's written consent (~~which will not be unreasonably withheld~~) given after prior written notice to Engineer.
- C. Engineer shall record time and costs required by Engineer and Engineer's Consultants to provide inspection services due to Contractor's working beyond regular working hours as defined in the General Requirements. Owner's reimbursement for the charges shall be a deduction from Contractor's Partial Payment(s) in accordance with Section 01 11 00 Part 2.02. (see SC-6.02.C)

6.03 *Services, Materials, and Equipment*

- A. Unless otherwise specified in the Contract Documents, Contractor shall provide and assume full responsibility for all services, materials, equipment, labor, transportation, construction equipment and machinery, tools, appliances, fuel, power, light, heat, telephone, water, sanitary facilities, temporary facilities, and all other facilities and incidentals necessary for the performance, testing, start-up, and completion of the Work.
- B. All materials and equipment incorporated into the Work shall be as specified or, if not specified, shall be of good quality and new, except as otherwise provided in the Contract Documents. All special warranties and guarantees required by the Specifications shall expressly run to the benefit of Owner. If required by Engineer, Contractor shall furnish satisfactory evidence (including reports of required tests) as to the source, kind, and quality of materials and equipment.
- C. All materials and equipment shall be stored, applied, installed, connected, erected, protected, used, cleaned, and conditioned in accordance with instructions of the applicable Supplier, except as otherwise may be provided in the Contract Documents.

6.04 Progress Schedule

- A. Contractor shall adhere to the Progress Schedule established in accordance with Paragraph 2.07 as it may be adjusted from time to time as provided below.
1. Contractor shall submit to Engineer for acceptance (to the extent indicated in Paragraph 2.07) proposed adjustments in the Progress Schedule that will not result in changing the Contract Times. Such adjustments will comply with any provisions of the General Requirements applicable thereto.
 2. Proposed adjustments in the Progress Schedule that will change the Contract Times shall be submitted in accordance with the requirements of Article 12. Adjustments in Contract Times may only be made by a Change Order.

6.05 Substitutes and "Or-Equals"

- A. Whenever an item of material or equipment is specified or described in the Contract Documents by using the name of a proprietary item or the name of a particular Supplier, the specification or description is intended to establish the type, function, appearance, and quality required. Unless the specification or description contains or is followed by words reading that no like, equivalent, or "or-equal" item or no substitution is permitted, other items of material or equipment or material or equipment of other Suppliers may be submitted to Engineer for review under the circumstances described below.
1. "*Or-Equal*" Items: If in Engineer's sole discretion an item of material or equipment proposed by Contractor is functionally equal to that named and sufficiently similar so that no change in related Work will be required, it may be considered by Engineer as an "or-equal" item, in which case review and approval of the proposed item may, in Engineer's sole discretion, be accomplished without compliance with some or all of the requirements for approval of proposed substitute items. For the purposes of this Paragraph 6.05.A.1, a proposed item of material or equipment will be considered functionally equal to an item so named if:
 - a. in the exercise of reasonable judgment Engineer determines that:
 - 1) it is at least equal in materials of construction, quality, durability, appearance, strength, and design characteristics;
 - 2) it will reliably perform at least equally well the function and achieve the results imposed by the design concept of the completed Project as a functioning whole; and
 - 3) it has a proven record of performance and availability of responsive service.
 - b. Contractor certifies that, if approved and incorporated into the Work:
 - 1) there will be no increase in cost to the Owner or increase in Contract Times; and
 - 2) it will conform substantially to the detailed requirements of the item named in the Contract Documents.

2. *Substitute Items:*

- a. If in Engineer's sole discretion an item of material or equipment proposed by Contractor does not qualify as an "or-equal" item under Paragraph 6.05.A.1, it will be considered a proposed substitute item.
- b. Contractor shall submit sufficient information as provided below to allow Engineer to determine if the item of material or equipment proposed is essentially equivalent to that named and an acceptable substitute therefor. Requests for review of proposed substitute items of material or equipment will not be accepted by Engineer from anyone other than Contractor.
- c. The requirements for review by Engineer will be as set forth in Paragraph 6.05.A.2.d, as supplemented by the General Requirements, and as Engineer may decide is appropriate under the circumstances.
- d. Contractor shall make written application to Engineer for review of a proposed substitute item of material or equipment that Contractor seeks to furnish or use. The application:
 - 1) shall certify that the proposed substitute item will:
 - a) perform adequately the functions and achieve the results called for by the general design,
 - b) be similar in substance to that specified, and
 - c) be suited to the same use as that specified;
 - 2) will state:
 - a) the extent, if any, to which the use of the proposed substitute item will prejudice Contractor's achievement of Substantial Completion on time,
 - b) whether use of the proposed substitute item in the Work will require a change in any of the Contract Documents (or in the provisions of any other direct contract with Owner for other work on the Project) to adapt the design to the proposed substitute item, and
 - c) whether incorporation or use of the proposed substitute item in connection with the Work is subject to payment of any license fee or royalty;
 - 3) will identify:
 - a) all variations of the proposed substitute item from that specified, and
 - b) available engineering, sales, maintenance, repair, and replacement services; and
 - 4) shall contain an itemized estimate of all costs or credits that will result directly or indirectly from use of such substitute item, including costs of redesign and claims of other contractors affected by any resulting change.

- e. Each action mentioned above required for review of proposed substitute items of material or equipment shall be followed in the order given. Failure to do so shall be cause for rejection of the proposed substitution. (see SC-6.05.A.2.e)
 - f. Contractor shall reimburse Owner for the charges of Engineer or Engineer's Consultants for evaluation of substitutions. Owner's reimbursement for the charges shall be a deduction from the Contractor's Partial Payment(s). (see SC-6.05.A.2.f)
- B. *Substitute Construction Methods or Procedures:* If a specific means, method, technique, sequence, or procedure of construction is expressly required by the Contract Documents, Contractor may furnish or utilize a substitute means, method, technique, sequence, or procedure of construction approved by Engineer. Contractor shall submit sufficient information to allow Engineer, in Engineer's sole discretion, to determine that the substitute proposed is equivalent to that expressly called for by the Contract Documents. The requirements for review by Engineer will be similar to those provided in Paragraph 6.05.A.2.
- C. *Engineer's Evaluation:* Engineer will be allowed a reasonable time within which to evaluate each proposal or submittal made pursuant to Paragraphs 6.05.A and 6.05.B. Engineer may require Contractor to furnish additional data about the proposed substitute item. Engineer will be the sole judge of acceptability. No "or equal" or substitute will be ordered, installed or utilized until Engineer's review is complete, which will be evidenced by a Change Order in the case of a substitute and an approved Shop Drawing for an "or equal." Engineer will advise Contractor in writing of any negative determination.
- D. *Special Guarantee:* Owner may require Contractor to furnish at Contractor's expense a special performance guarantee or other surety with respect to any substitute.
- E. *Engineer's Cost Reimbursement:* Engineer will record Engineer's costs in evaluating a substitute proposed or submitted by Contractor pursuant to Paragraphs 6.05.A.2 and 6.05.B. Whether or not Engineer approves a substitute so proposed or submitted by Contractor, Contractor shall reimburse Owner for the reasonable charges of Engineer for evaluating each such proposed substitute. Contractor shall also reimburse Owner for the reasonable charges of Engineer for making changes in the Contract Documents (or in the provisions of any other direct contract with Owner) resulting from the acceptance of each proposed substitute.
- F. *Contractor's Expense:* Contractor shall provide all data in support of any proposed substitute or "or-equal" at Contractor's expense.

6.06 *Concerning Subcontractors, Suppliers, and Others*

- A. Contractor shall not employ any Subcontractor, Supplier, or other individual or entity (including those acceptable to Owner as indicated in Paragraph 6.06.B), whether initially or as a replacement, against whom Owner may have reasonable objection. Contractor shall not be required to employ any Subcontractor, Supplier, or other individual or entity to furnish or perform any of the Work against whom Contractor has reasonable objection. Contractor shall not subcontract part(s) or the work, the aggregate cost of which is greater than 50-40 percent of the contract price, without prior written approval by Owner. Contractor shall cause appropriate provisions to be inserted in all subcontracts relative to the Work that bind Subcontractors to Contractor by the terms of the Contract Documents insofar as applicable to the work of

Subcontractors and to give Contractor the same power as regards terminating any subcontract that Owner may exercise over Contractor under any provision of the Contract Documents. Nothing contained in the subcontract shall create any contractual relationship between Subcontractor and Owner. Each Subcontractor shall discharge all duties and responsibilities of Contractor to Owner covered by his subcontract. (see SC-6.06.A)

- B. If the Supplementary Conditions require the identity of certain Subcontractors, Suppliers, or other individuals or entities to be submitted to Owner in advance for acceptance by Owner by a specified date prior to the Effective Date of the Agreement, and if Contractor has submitted a list thereof in accordance with the Supplementary Conditions, Owner's acceptance (either in writing or by failing to make written objection thereto by the date indicated for acceptance or objection in the Bidding Documents or the Contract Documents) of any such Subcontractor, Supplier, or other individual or entity so identified may be revoked on the basis of reasonable objection after due investigation. Contractor shall submit an acceptable replacement for the rejected Subcontractor, Supplier, or other individual or entity, and the Contract Price will be adjusted by the difference in the cost occasioned by such replacement, and an appropriate Change Order will be issued. No acceptance by Owner of any such Subcontractor, Supplier, or other individual or entity, whether initially or as a replacement, shall constitute a waiver of any right of Owner or Engineer to reject defective Work. Subcontractors and Suppliers shall be identified on the form provided in the Bidding Requirements. (see SC-6.06.B)
- C. Contractor shall be fully responsible to Owner and Engineer for all acts and omissions of the Subcontractors, Suppliers, and other individuals or entities performing or furnishing any of the Work just as Contractor is responsible for Contractor's own acts and omissions. Nothing in the Contract Documents:
1. shall create for the benefit of any such Subcontractor, Supplier, or other individual or entity any contractual relationship between Owner or Engineer and any such Subcontractor, Supplier or other individual or entity; nor
 2. shall create any obligation on the part of Owner or Engineer to pay or to see to the payment of any moneys due any such Subcontractor, Supplier, or other individual or entity except as may otherwise be required by Laws and Regulations.
- D. Contractor shall be solely responsible for scheduling and coordinating the Work of Subcontractors, Suppliers, and other individuals or entities performing or furnishing any of the Work under a direct or indirect contract with Contractor.
- E. Contractor shall require all Subcontractors, Suppliers, and such other individuals or entities performing or furnishing any of the Work to communicate with Engineer through Contractor.
- F. The divisions and sections of the Specifications and the identifications of any Drawings shall not control Contractor in dividing the Work among Subcontractors or Suppliers or delineating the Work to be performed by any specific trade.
- G. All Work performed for Contractor by a Subcontractor or Supplier will be pursuant to an appropriate agreement between Contractor and the Subcontractor or Supplier which specifically binds the Subcontractor or Supplier to the applicable terms and conditions of the Contract Documents for the benefit of Owner and Engineer. Whenever any such agreement is with a

Subcontractor or Supplier who is listed as a loss payee on the property insurance provided in Paragraph 5.06, the agreement between the Contractor and the Subcontractor or Supplier will contain provisions whereby the Subcontractor or Supplier waives all rights against Owner, Contractor, Engineer, and all other individuals or entities identified in the Supplementary Conditions to be listed as insureds or loss payees (and the officers, directors, members, partners, employees, agents, consultants, and subcontractors of each and any of them) for all losses and damages caused by, arising out of, relating to, or resulting from any of the perils or causes of loss covered by such policies and any other property insurance applicable to the Work. If the insurers on any such policies require separate waiver forms to be signed by any Subcontractor or Supplier, Contractor will obtain the same.

6.07 *Patent Fees and Royalties*

- A. Contractor shall pay all license fees and royalties and assume all costs incident to the use in the performance of the Work or the incorporation in the Work of any invention, design, process, product, or device which is the subject of patent rights or copyrights held by others. If a particular invention, design, process, product, or device is specified in the Contract Documents for use in the performance of the Work and if, to the actual knowledge of Owner or Engineer, its use is subject to patent rights or copyrights calling for the payment of any license fee or royalty to others, the existence of such rights shall be disclosed by Owner in the Contract Documents.
- B. To the fullest extent permitted by Laws and Regulations, Owner shall indemnify and hold harmless Contractor, and its officers, directors, members, partners, employees, agents, consultants, and subcontractors from and against all claims, costs, losses, and damages (including but not limited to all fees and charges of engineers, architects, attorneys, and other professionals, and all court or arbitration or other dispute resolution costs) arising out of or relating to any infringement of patent rights or copyrights incident to the use in the performance of the Work or resulting from the incorporation in the Work of any invention, design, process, product, or device specified in the Contract Documents, but not identified as being subject to payment of any license fee or royalty to others required by patent rights or copyrights.
- C. To the fullest extent permitted by Laws and Regulations, Contractor shall indemnify and hold harmless Owner and Engineer, and the officers, directors, members, partners, employees, agents, consultants and subcontractors of each and any of them from and against all claims, costs, losses, and damages (including but not limited to all fees and charges of engineers, architects, attorneys, and other professionals and all court or arbitration or other dispute resolution costs) arising out of or relating to any infringement of patent rights or copyrights incident to the use in the performance of the Work or resulting from the incorporation in the Work of any invention, design, process, product, or device not specified in the Contract Documents.

6.08 *Permits*

- A. Unless otherwise provided in the Supplementary Conditions, Contractor shall obtain and pay for all construction permits and licenses. Owner shall assist Contractor, when necessary, in obtaining such permits and licenses. Contractor shall pay all governmental charges and inspection fees necessary for the prosecution of the Work which are applicable at the time of opening of Bids, or, if there are no Bids, on the Effective Date of the Agreement. Owner shall pay all charges of utility owners for connections for providing permanent service to the Work.

Permits, licenses, and easements for permanent structures or permanent changes in existing facilities shall be secured and paid for by Owner, unless otherwise specified. (see SC-6.08.A)

6.09 *Laws and Regulations*

- A. Contractor shall give all notices required by and shall comply with all Laws and Regulations applicable to the performance of the Work. Except where otherwise expressly required by applicable Laws and Regulations, neither Owner nor Engineer shall be responsible for monitoring Contractor's compliance with any Laws or Regulations. Contractor shall also cause all Subcontractors to comply with all federal, state, county, and municipal laws, ordinances, rules, and regulations bearing on the conduct of the Work. (see SC-6.09.A)
- B. If Contractor performs any Work knowing or having reason to know that it is contrary to Laws or Regulations, Contractor shall bear all claims, costs, losses, and damages (including but not limited to all fees and charges of engineers, architects, attorneys, and other professionals and all court or arbitration or other dispute resolution costs) arising out of or relating to such Work. However, it shall not be Contractor's responsibility to make certain that the Specifications and Drawings are in accordance with Laws and Regulations, but this shall not relieve Contractor of Contractor's obligations under Paragraph 3.03. If Contractor observes that the Contract Documents are at variance with said laws, ordinances, rates, or regulations, Contractor shall promptly notify Engineer of Record and the County in writing, and any necessary changes shall be adjusted as provided in the Contract Documents. Contractor shall not proceed with the Work until so instructed by Owner. (see SC-6.09.B)
- C. Changes in Laws or Regulations not known at the time of opening of Bids (or, on the Effective Date of the Agreement if there were no Bids) having an effect on the cost or time of performance of the Work shall be the subject of an adjustment in Contract Price or Contract Times. If Owner and Contractor are unable to agree on entitlement to or on the amount or extent, if any, of any such adjustment, a Claim may be made therefor as provided in Paragraph 10.05.

6.10 *Taxes*

- A. Contractor shall pay all sales, consumer, use, and other similar taxes required to be paid by Contractor in accordance with the Laws and Regulations of the place of the Project which are applicable during the performance of the Work.

6.11 *Use of Site and Other Areas*

A. Limitation on Use of Site and Other Areas:

1. Contractor shall confine construction equipment, the storage of materials and equipment, and the operations of workers to the Site and other areas permitted by Laws and Regulations, and shall not unreasonably encumber the Site and other areas with construction equipment or other materials or equipment. Contractor shall assume full responsibility for any damage to any such land or area, or to the owner or occupant thereof, or of any adjacent land or areas resulting from the performance of the Work.

2. Should any claim be made by any such owner or occupant because of the performance of the Work, Contractor shall promptly settle with such other party by negotiation or otherwise resolve the claim by arbitration or other dispute resolution proceeding or at law.
 3. To the fullest extent permitted by Laws and Regulations, Contractor shall indemnify and hold harmless Owner and Engineer, and the officers, directors, members, partners, employees, agents, consultants and subcontractors of each and any of them from and against all claims, costs, losses, and damages (including but not limited to all fees and charges of engineers, architects, attorneys, and other professionals and all court or arbitration or other dispute resolution costs) arising out of or relating to any claim or action, legal or equitable, brought by any such owner or occupant against Owner, Engineer, or any other party indemnified hereunder to the extent caused by or based upon Contractor's performance of the Work.
- B. *Removal of Debris During Performance of the Work:* During the progress of the Work Contractor shall keep the Site and other areas free from accumulations of waste materials, rubbish, and other debris. Removal and disposal of such waste materials, rubbish, and other debris shall conform to applicable Laws and Regulations.
- C. *Cleaning:* Prior to Substantial Completion of the Work Contractor shall clean the Site and the Work and make it ready for utilization by Owner. At the completion of the Work Contractor shall remove from the Site all tools, appliances, construction equipment and machinery, and surplus materials and shall restore to original condition all property not designated for alteration by the Contract Documents.
- D. *Loading Structures:* Contractor shall not load nor permit any part of any structure to be loaded in any manner that will endanger the structure, nor shall Contractor subject any part of the Work or adjacent property to stresses or pressures that will endanger it.

6.12 *Record Documents*

- A. Contractor shall maintain in a safe place at the Site one record copy of all Drawings, Specifications, Addenda, Change Orders, Work Change Directives, Field Orders, and written interpretations and clarifications in good order and annotated to show changes made during construction. These record documents together with all approved Samples and a counterpart of all approved Shop Drawings will be available to Engineer for reference. Upon completion of the Work, these record documents, Samples, and Shop Drawings will be delivered to Engineer for Owner. Annotations of record documents shall be legible, precise, and complete as determined by Engineer of Record and the County. (see SC-6.12.A)

6.13 *Safety and Protection*

- A. Contractor shall be solely responsible for initiating, maintaining and supervising all safety precautions and programs in connection with the Work. Such responsibility does not relieve Subcontractors of their responsibility for the safety of persons or property in the performance of their work, nor for compliance with applicable safety Laws and Regulations. Contractor shall take all necessary precautions for the safety of, and shall provide the necessary protection to prevent damage, injury or loss to:

1. all persons on the Site or who may be affected by the Work;
 2. all the Work and materials and equipment to be incorporated therein, whether in storage on or off the Site; and
 3. other property at the Site or adjacent thereto, including trees, shrubs, lawns, walks, pavements, roadways, structures, utilities, and Underground Facilities not designated for removal, relocation, or replacement in the course of construction.
- B. Contractor shall comply with all applicable Laws and Regulations relating to the safety of persons or property, or to the protection of persons or property from damage, injury, or loss; and shall erect and maintain all necessary safeguards for such safety and protection. Contractor shall notify owners of adjacent property and of Underground Facilities and other utility owners when prosecution of the Work may affect them, and shall cooperate with them in the protection, removal, relocation, and replacement of their property.
- C. Contractor shall comply with the applicable requirements of Owner's safety programs, if any. The Supplementary Conditions identify any Owner's safety programs that are applicable to the Work.
- D. Contractor shall inform Owner and Engineer of the specific requirements of Contractor's safety program with which Owner's and Engineer's employees and representatives must comply while at the Site.
- E. All damage, injury, or loss to any property referred to in Paragraph 6.13.A.2 or 6.13.A.3 caused, directly or indirectly, in whole or in part, by Contractor, any Subcontractor, Supplier, or any other individual or entity directly or indirectly employed by any of them to perform any of the Work, or anyone for whose acts any of them may be liable, shall be remedied by Contractor (except damage or loss attributable to the fault of Drawings or Specifications or to the acts or omissions of Owner or Engineer or anyone employed by any of them, or anyone for whose acts any of them may be liable, and not attributable, directly or indirectly, in whole or in part, to the fault or negligence of Contractor or any Subcontractor, Supplier, or other individual or entity directly or indirectly employed by any of them).
- F. Contractor's duties and responsibilities for safety and for protection of the Work shall continue until such time as all the Work is completed and Engineer has issued a notice to Owner and Contractor in accordance with Paragraph 14.07.B that the Work is acceptable (except as otherwise expressly provided in connection with Substantial Completion).
- G. Contractor shall be responsible at all times for precautions to achieve the protection of all persons, including employees and property. Contractor shall make special effort to detect hazardous conditions and shall take prompt action where necessary to avoid accident, injury, or property damage. OSHA and all other applicable safety laws and ordinances shall be followed as well as American National Standards Institute Safety Standards. All accidents, injuries, claims, or potential claims shall be reported promptly to Owner. (see SC-6.13.G)

6.14 *Safety Representative*

- A. Contractor shall designate a qualified and experienced safety representative at the Site whose duties and responsibilities shall be the prevention of accidents and the maintaining and supervising of safety precautions and programs.

6.15 *Hazard Communication Programs*

- A. Contractor shall be responsible for coordinating any exchange of material safety data sheets or other hazard communication information required to be made available to or exchanged between or among employers at the Site in accordance with Laws or Regulations.

6.16 *Emergencies*

- A. In emergencies affecting the safety or protection of persons or the Work or property at the Site or adjacent thereto, Contractor is obligated to act to prevent threatened damage, injury, or loss. Contractor shall give Engineer prompt written notice if Contractor believes that any significant changes in the Work or variations from the Contract Documents have been caused thereby or are required as a result thereof. If Engineer determines that a change in the Contract Documents is required because of the action taken by Contractor in response to such an emergency, a Work Change Directive or Change Order will be issued.

6.17 *Shop Drawings and Samples*

- A. Contractor shall submit Shop Drawings and Samples to Engineer for review and approval in accordance with the accepted Schedule of Submittals (as required by Paragraph 2.07). Each submittal will be identified as Engineer may require.

1. *Shop Drawings:*

- a. Submit number of copies specified in the General Requirements.
- b. Data shown on the Shop Drawings will be complete with respect to quantities, dimensions, specified performance and design criteria, materials, and similar data to show Engineer the services, materials, and equipment Contractor proposes to provide and to enable Engineer to review the information for the limited purposes required by Paragraph 6.17.D.

2. *Samples:*

- a. Submit number of Samples specified in the Specifications.
 - b. Clearly identify each Sample as to material, Supplier, pertinent data such as catalog numbers, the use for which intended and other data as Engineer may require to enable Engineer to review the submittal for the limited purposes required by Paragraph 6.17.D.
- B. Where a Shop Drawing or Sample is required by the Contract Documents or the Schedule of Submittals, any related Work performed prior to Engineer's review and approval of the pertinent submittal will be at the sole expense and responsibility of Contractor.

C. Submittal Procedures:

1. Before submitting each Shop Drawing or Sample, Contractor shall have:
 - a. reviewed and coordinated each Shop Drawing or Sample with other Shop Drawings and Samples and with the requirements of the Work and the Contract Documents;
 - b. determined and verified all field measurements, quantities, dimensions, specified performance and design criteria, installation requirements, materials, catalog numbers, and similar information with respect thereto;
 - c. determined and verified the suitability of all materials offered with respect to the indicated application, fabrication, shipping, handling, storage, assembly, and installation pertaining to the performance of the Work; and
 - d. determined and verified all information relative to Contractor's responsibilities for means, methods, techniques, sequences, and procedures of construction, and safety precautions and programs incident thereto.
2. Each submittal shall bear a stamp or specific written certification that Contractor has satisfied Contractor's obligations under the Contract Documents with respect to Contractor's review and approval of that submittal.
3. With each submittal, Contractor shall give Engineer specific written notice of any variations that the Shop Drawing or Sample may have from the requirements of the Contract Documents. This notice shall be both a written communication separate from the Shop Drawings or Sample submittal; and, in addition, by a specific notation made on each Shop Drawing or Sample submitted to Engineer for review and approval of each such variation.

D. Engineer's Review:

1. Engineer will provide timely review of Shop Drawings and Samples in accordance with the Schedule of Submittals acceptable to Engineer. Engineer's review and approval will be only to determine if the items covered by the submittals will, after installation or incorporation in the Work, conform to the information given in the Contract Documents and be compatible with the design concept of the completed Project as a functioning whole as indicated by the Contract Documents.
2. Engineer's review and approval will not extend to means, methods, techniques, sequences, or procedures of construction (except where a particular means, method, technique, sequence, or procedure of construction is specifically and expressly called for by the Contract Documents) or to safety precautions or programs incident thereto. The review and approval of a separate item as such will not indicate approval of the assembly in which the item functions.
3. Engineer's review and approval shall not relieve Contractor from responsibility for any variation from the requirements of the Contract Documents unless Contractor has complied with the requirements of Paragraph 6.17.C.3 and Engineer has given written approval of each such variation by specific written notation thereof incorporated in or accompanying the

Shop Drawing or Sample. Engineer's review and approval shall not relieve Contractor from responsibility for complying with the requirements of Paragraph 6.17.C.1.

E. Resubmittal Procedures:

1. Contractor shall make corrections required by Engineer and shall return the required number of corrected copies of Shop Drawings and submit, as required, new Samples for review and approval. Contractor shall direct specific attention in writing to revisions other than the corrections called for by Engineer on previous submittals.
2. Contractor shall reimburse Owner for the charges of the County and the County's Consultants for costs generated as a result of more than two submittals of any one Shop Drawing or Sample being required for evaluation due to rejection for noncompliance of the original submittal or lack of information required by the Contract Documents. Owner's reimbursement for the charges shall be a deduction from Contractor's Partial Payment(s). (see SC-6.17.E.2)

6.18 Continuing the Work

- A. Contractor shall carry on the Work and adhere to the Progress Schedule during all disputes or disagreements with Owner. No Work shall be delayed or postponed pending resolution of any disputes or disagreements, except as permitted by Paragraph 15.04 or as Owner and Contractor may otherwise agree in writing.

6.19 Contractor's General Warranty and Guarantee

- A. Contractor warrants and guarantees to Owner that all Work will be in accordance with the Contract Documents and will not be defective. Engineer and its officers, directors, members, partners, employees, agents, consultants, and subcontractors shall be entitled to rely on representation of Contractor's warranty and guarantee.
- B. Contractor's warranty and guarantee hereunder excludes defects or damage caused by:
 1. abuse, modification, or improper maintenance or operation by persons other than Contractor, Subcontractors, Suppliers, or any other individual or entity for whom Contractor is responsible; or
 2. normal wear and tear under normal usage.
- C. Contractor's obligation to perform and complete the Work in accordance with the Contract Documents shall be absolute. None of the following will constitute an acceptance of Work that is not in accordance with the Contract Documents or a release of Contractor's obligation to perform the Work in accordance with the Contract Documents:
 1. observations by Engineer;
 2. recommendation by Engineer or payment by Owner of any progress or final payment;
 3. the issuance of a certificate of Substantial Completion by Engineer or any payment related thereto by Owner;

4. use or occupancy of the Work or any part thereof by Owner;
5. any review and approval of a Shop Drawing or Sample submittal or the issuance of a notice of acceptability by Engineer;
6. any inspection, test, or approval by others; or
7. any correction of defective Work by Owner.

6.20 Indemnification

- A. To the fullest extent permitted by Laws and Regulations, Contractor shall indemnify and hold harmless Owner and Engineer, and the officers, directors, members, partners, employees, agents, consultants and subcontractors of each and any of them from and against all claims, costs, losses, and damages (including but not limited to all fees and charges of engineers, architects, attorneys, and other professionals and all court or arbitration or other dispute resolution costs) arising out of or relating to the performance of the Work, provided that any such claim, cost, loss, or damage is attributable to bodily injury, sickness, disease, or death, or to injury to or destruction of tangible property (other than the Work itself), including the loss of use resulting therefrom but only to the extent caused by any negligent act or omission of Contractor, any Subcontractor, any Supplier, or any individual or entity directly or indirectly employed by any of them to perform any of the Work or anyone for whose acts any of them may be liable. (see SC-6.20.A)
- B. In any and all claims against Owner or Engineer or any of their officers, directors, members, partners, employees, agents, consultants, or subcontractors by any employee (or the survivor or personal representative of such employee) of Contractor, any Subcontractor, any Supplier, or any individual or entity directly or indirectly employed by any of them to perform any of the Work, or anyone for whose acts any of them may be liable, the indemnification obligation under Paragraph 6.20.A shall not be limited in any way by any limitation on the amount or type of damages, compensation, or benefits payable by or for Contractor or any such Subcontractor, Supplier, or other individual or entity under workers' compensation acts, disability benefit acts, or other employee benefit acts.
- C. The indemnification obligations of Contractor under Paragraph 6.20.A shall not extend to the liability of Engineer and Engineer's officers, directors, members, partners, employees, agents, consultants and subcontractors arising out of:
 1. the preparation or approval of, or the failure to prepare or approve maps, Drawings, opinions, reports, surveys, Change Orders, designs, or Specifications; or
 2. giving directions or instructions, or failing to give them, if that is the primary cause of the injury or damage.
- D. Neither Contractor nor Owner shall sell, transfer, assign, or otherwise dispose of the contract or any portion thereof, or any right, title, or interest therein, or any obligations thereunder, without written consent of the other party. (see SC-6.20.D)

6.21 *Delegation of Professional Design Services*

- A. Contractor will not be required to provide professional design services unless such services are specifically required by the Contract Documents for a portion of the Work or unless such services are required to carry out Contractor's responsibilities for construction means, methods, techniques, sequences and procedures. Contractor shall not be required to provide professional services in violation of applicable law.
- B. If professional design services or certifications by a design professional related to systems, materials or equipment are specifically required of Contractor by the Contract Documents, Owner and Engineer will specify all performance and design criteria that such services must satisfy. Contractor shall cause such services or certifications to be provided by a properly licensed professional, whose signature and seal shall appear on all drawings, calculations, specifications, certifications, Shop Drawings and other submittals prepared by such professional. Shop Drawings and other submittals related to the Work designed or certified by such professional, if prepared by others, shall bear such professional's written approval when submitted to Engineer.
- C. Owner and Engineer shall be entitled to rely upon the adequacy, accuracy and completeness of the services, certifications or approvals performed by such design professionals, provided Owner and Engineer have specified to Contractor all performance and design criteria that such services must satisfy.
- D. Pursuant to this Paragraph 6.21, Engineer's review and approval of design calculations and design drawings will be only for the limited purpose of checking for conformance with performance and design criteria given and the design concept expressed in the Contract Documents. Engineer's review and approval of Shop Drawings and other submittals (except design calculations and design drawings) will be only for the purpose stated in Paragraph 6.17.D.1.
- E. Contractor shall not be responsible for the adequacy of the performance or design criteria required by the Contract Documents.

ARTICLE 7 – OTHER WORK AT THE SITE

7.01 *Related Work at Site*

- A. Owner may perform other work related to the Project at the Site with Owner's employees, or through other direct contracts therefor, or have other work performed by utility owners. If such other work is not noted in the Contract Documents, then:
 - 1. written notice thereof will be given to Contractor prior to starting any such other work; and
 - 2. if Owner and Contractor are unable to agree on entitlement to or on the amount or extent, if any, of any adjustment in the Contract Price or Contract Times that should be allowed as a result of such other work, a Claim may be made therefor as provided in Paragraph 10.05.
- B. Contractor shall afford each other contractor who is a party to such a direct contract, each utility owner, and Owner, if Owner is performing other work with Owner's employees, proper and safe

access to the Site, provide a reasonable opportunity for the introduction and storage of materials and equipment and the execution of such other work, and properly coordinate the Work with theirs. Contractor shall do all cutting, fitting, and patching of the Work that may be required to properly connect or otherwise make its several parts come together and properly integrate with such other work. Contractor shall not endanger any work of others by cutting, excavating, or otherwise altering such work; provided, however, that Contractor may cut or alter others' work with the written consent of Engineer and the others whose work will be affected. The duties and responsibilities of Contractor under this Paragraph are for the benefit of such utility owners and other contractors to the extent that there are comparable provisions for the benefit of Contractor in said direct contracts between Owner and such utility owners and other contractors.

- C. If the proper execution or results of any part of Contractor's Work depends upon work performed by others under this Article 7, Contractor shall inspect such other work and promptly report to Engineer in writing any delays, defects, or deficiencies in such other work that render it unavailable or unsuitable for the proper execution and results of Contractor's Work. Contractor's failure to so report will constitute an acceptance of such other work as fit and proper for integration with Contractor's Work except for latent defects and deficiencies in such otherwork.

7.02 *Coordination*

- A. If Owner intends to contract with others for the performance of other work on the Project at the Site, the following will be set forth in Supplementary Conditions:
 - 1. the individual or entity who will have authority and responsibility for coordination of the activities among the various contractors will be identified;
 - 2. the specific matters to be covered by such authority and responsibility will be itemized; and
 - 3. the extent of such authority and responsibilities will be provided.
- B. Unless otherwise provided in the Supplementary Conditions, Owner shall have sole authority and responsibility for such coordination.

7.03 *Legal Relationships*

- A. Paragraphs 7.01.A and 7.02 are not applicable for utilities not under the control of Owner.
- B. Each other direct contract of Owner under Paragraph 7.01.A shall provide that the other contractor is liable to Owner and Contractor for the reasonable direct delay and disruption costs incurred by Contractor as a result of the other contractor's wrongful actions or inactions.
- C. Contractor shall be liable to Owner and any other contractor under direct contract to Owner for the reasonable direct delay and disruption costs incurred by such other contractor as a result of Contractor's wrongful action or inactions.

ARTICLE 8 – OWNER’S RESPONSIBILITIES**8.01 Communications to Contractor**

- A. Except as otherwise provided in these General Conditions, Owner shall issue all communications to Contractor through Engineer.

8.02 Replacement of Engineer

- A. In case of termination of the employment of Engineer, Owner shall appoint an engineer to whom Contractor makes no reasonable objection, whose status under the Contract Documents shall be that of the former Engineer. (see SC-8.02)

8.03 Furnish Data

- A. Owner shall promptly furnish the data required of Owner under the Contract Documents.

8.04 Pay When Due

- A. Owner shall make payments to Contractor when they are due as provided in Paragraphs 14.02.C and 14.07.C.

8.05 Lands and Easements; Reports and Tests

- A. Owner’s duties with respect to providing lands and easements and providing engineering surveys to establish reference points are set forth in Paragraphs 4.01 and 4.05. Paragraph 4.02 refers to Owner’s identifying and making available to Contractor copies of reports of explorations and tests of subsurface conditions and drawings of physical conditions relating to existing surface or subsurface structures at the Site.

8.06 Insurance

- A. Owner’s responsibilities, if any, with respect to purchasing and maintaining liability and property insurance are set forth in Article 5.

8.07 Change Orders

- A. Owner is obligated to execute Change Orders as indicated in Paragraph 10.03.

8.08 Inspections, Tests, and Approvals

- A. Owner’s responsibility with respect to certain inspections, tests, and approvals is set forth in Paragraph 13.03.B.

8.09 Limitations on Owner’s Responsibilities

- A. The Owner shall not supervise, direct, or have control or authority over, nor be responsible for, Contractor’s means, methods, techniques, sequences, or procedures of construction, or the safety precautions and programs incident thereto, or for any failure of Contractor to comply with Laws

and Regulations applicable to the performance of the Work. Owner will not be responsible for Contractor's failure to perform the Work in accordance with the Contract Documents.

8.10 Undisclosed Hazardous Environmental Condition

- A. Owner's responsibility in respect to an undisclosed Hazardous Environmental Condition is set forth in Paragraph 4.06.

8.11 Evidence of Financial Arrangements

- A. Upon request of Contractor, Owner shall furnish Contractor reasonable evidence that financial arrangements have been made to satisfy Owner's obligations under the Contract Documents.

8.12 Compliance with Safety Program

- A. While at the Site, Owner's employees and representatives shall comply with the specific applicable requirements of Contractor's safety programs of which Owner has been informed pursuant to Paragraph 6.13.D.

ARTICLE 9 – ENGINEER'S STATUS DURING CONSTRUCTION

9.01 Owner's Representative

- A. Engineer will be Owner's representative during the construction period. The duties and responsibilities and the limitations of authority of Engineer as Owner's representative during construction are set forth in the Contract Documents.

9.02 Visits to Site

- A. Engineer will make visits to the Site at intervals appropriate to the various stages of construction as Engineer deems necessary in order to observe as an experienced and qualified design professional the progress that has been made and the quality of the various aspects of Contractor's executed Work. Based on information obtained during such visits and observations, Engineer, for the benefit of Owner, will determine, in general, if the Work is proceeding in accordance with the Contract Documents. Engineer will not be required to make exhaustive or continuous inspections on the Site to check the quality or quantity of the Work. Engineer's efforts will be directed toward providing for Owner a greater degree of confidence that the completed Work will conform generally to the Contract Documents. On the basis of such visits and observations, Engineer will keep Owner informed of the progress of the Work and will endeavor to guard Owner against defective Work.
- B. Engineer's visits and observations are subject to all the limitations on Engineer's authority and responsibility set forth in Paragraph 9.09. Particularly, but without limitation, during or as a result of Engineer's visits or observations of Contractor's Work, Engineer will not supervise, direct, control, or have authority over or be responsible for Contractor's means, methods, techniques, sequences, or procedures of construction, or the safety precautions and programs incident thereto, or for any failure of Contractor to comply with Laws and Regulations applicable to the performance of the Work.

9.03 *Project Representative*

- A. If Owner and Engineer agree, Engineer will furnish a Resident Project Representative to assist Engineer in providing more extensive observation of the Work. The authority and responsibilities of any such Resident Project Representative and assistants will be as provided in the Supplementary Conditions, and limitations on the responsibilities thereof will be as provided in Paragraph 9.09. If Owner designates another representative or agent to represent Owner at the Site who is not Engineer's consultant, agent or employee, the responsibilities and authority and limitations thereon of such other individual or entity will be as provided in the Supplementary Conditions.

9.04 *Authorized Variations in Work*

- A. Engineer may authorize minor variations in the Work from the requirements of the Contract Documents which do not involve an adjustment in the Contract Price or the Contract Times and are compatible with the design concept of the completed Project as a functioning whole as indicated by the Contract Documents. These may be accomplished by a Field Order and will be binding on Owner and also on Contractor, who shall perform the Work involved promptly. If Owner or Contractor believes that a Field Order justifies an adjustment in the Contract Price or Contract Times, or both, and the parties are unable to agree on entitlement to or on the amount or extent, if any, of any such adjustment, a Claim may be made therefor as provided in Paragraph 10.05.

9.05 *Rejecting Defective Work*

- A. Engineer will have authority to reject Work which Engineer believes to be defective, or that Engineer believes will not produce a completed Project that conforms to the Contract Documents or that will prejudice the integrity of the design concept of the completed Project as a functioning whole as indicated by the Contract Documents. Engineer will also have authority to require special inspection or testing of the Work as provided in Paragraph 13.04, whether or not the Work is fabricated, installed, or completed.
- B. Contractor shall reimburse the Owner for the charges of Engineer and Engineer's Consultants for any additional field observations, engineering analysis, correspondence, meetings, or other work due to non-complying or defective construction, materials, or equipment performed or furnished by the Contractor, Subcontractors, or Suppliers. Owner's reimbursement for the charges shall be a deduction from the Contractor's Partial Payment(s). (see SC-9.05.B)

9.06 *Shop Drawings, Change Orders and Payments*

- A. In connection with Engineer's authority, and limitations thereof, as to Shop Drawings and Samples, see Paragraph 6.17.
- B. In connection with Engineer's authority, and limitations thereof, as to design calculations and design drawings submitted in response to a delegation of professional design services, if any, see Paragraph 6.21.
- C. In connection with Engineer's authority as to Change Orders, see Articles 10, 11, and 12.

D. In connection with Engineer's authority as to Applications for Payment, see Article 14.

9.07 Determinations for Unit Price Work

A. Engineer will determine the actual quantities and classifications of Unit Price Work performed by Contractor. Engineer will review with Contractor the Engineer's preliminary determinations on such matters before rendering a written decision thereon (by recommendation of an Application for Payment or otherwise). Engineer's written decision thereon will be final and binding (except as modified by Engineer to reflect changed factual conditions or more accurate data) upon Owner and Contractor, subject to the provisions of Paragraph 10.05.

9.08 Decisions on Requirements of Contract Documents and Acceptability of Work

A. Engineer will be the initial interpreter of the requirements of the Contract Documents and judge of the acceptability of the Work thereunder. All matters in question and other matters between Owner and Contractor arising prior to the date final payment is due relating to the acceptability of the Work, and the interpretation of the requirements of the Contract Documents pertaining to the performance of the Work, will be referred initially to Engineer in writing within 30 days of the event giving rise to the question.

B. Engineer will, with reasonable promptness, render a written decision on the issue referred. If Owner or Contractor believes that any such decision entitles them to an adjustment in the Contract Price or Contract Times or both, a Claim may be made under Paragraph 10.05. The date of Engineer's decision shall be the date of the event giving rise to the issues referenced for the purposes of Paragraph 10.05.B.

C. Engineer's written decision on the issue referred will be final and binding on Owner and Contractor, subject to the provisions of Paragraph 10.05.

D. When functioning as interpreter and judge under this Paragraph 9.08, Engineer will not show partiality to Owner or Contractor and will not be liable in connection with any interpretation or decision rendered in good faith in such capacity.

9.09 Limitations on Engineer's Authority and Responsibilities

A. Neither Engineer's authority or responsibility under this Article 9 or under any other provision of the Contract Documents nor any decision made by Engineer in good faith either to exercise or not exercise such authority or responsibility or the undertaking, exercise, or performance of any authority or responsibility by Engineer shall create, impose, or give rise to any duty in contract, tort, or otherwise owed by Engineer to Contractor, any Subcontractor, any Supplier, any other individual or entity, or to any surety for or employee or agent of any of them.

B. Engineer will not supervise, direct, control, or have authority over or be responsible for Contractor's means, methods, techniques, sequences, or procedures of construction, or the safety precautions and programs incident thereto, or for any failure of Contractor to comply with Laws and Regulations applicable to the performance of the Work. Engineer will not be responsible for Contractor's failure to perform the Work in accordance with the Contract Documents.

- C. Engineer will not be responsible for the acts or omissions of Contractor or of any Subcontractor, any Supplier, or of any other individual or entity performing any of the Work.
- D. Engineer's review of the final Application for Payment and accompanying documentation and all maintenance and operating instructions, schedules, guarantees, bonds, certificates of inspection, tests and approvals, and other documentation required to be delivered by Paragraph 14.07.A will only be to determine generally that their content complies with the requirements of, and in the case of certificates of inspections, tests, and approvals that the results certified indicate compliance with, the Contract Documents.
- E. The limitations upon authority and responsibility set forth in this Paragraph 9.09 shall also apply to the Resident Project Representative, if any, and assistants, if any.

9.10 *Compliance with Safety Program*

- A. While at the Site, Engineer's employees and representatives shall comply with the specific applicable requirements of Contractor's safety programs of which Engineer has been informed pursuant to Paragraph 6.13.D.

ARTICLE 10 – CHANGES IN THE WORK; CLAIMS

10.01 *Authorized Changes in the Work*

- A. Without invalidating the Contract and without notice to any surety, Owner may, at any time or from time to time, order additions, deletions, or revisions in the Work ~~by a Change Order, or a Work Change Directive pursuant to the Florida Department of Transportation (FDOT) Supplemental LAP Specifications. Upon receipt of any such document, Contractor shall promptly proceed with the Work involved which will be performed under the applicable conditions of the Contract Documents (except as otherwise specifically provided).~~
- B. If Owner and Contractor are unable to agree on entitlement to, or on the amount or extent, if any, of an adjustment in the Contract Price or Contract Times, or both, that should be allowed as a result of a Work Change Directive, a Claim may be made ~~therefor as provided in Paragraph 10.05~~ pursuant to the Florida Department of Transportation (FDOT) Supplemental LAP Specifications.

10.02 *Unauthorized Changes in the Work*

- A. Contractor shall not be entitled to an increase in the Contract Price or an extension of the Contract Times with respect to any work performed that is not required by the Contract Documents as amended, modified, or supplemented as provided in Paragraph 3.04, except in the case of an emergency as provided in Paragraph 6.16 or in the case of uncovering Work as provided in Paragraph 13.04.D.

10.03 *Execution of Change Orders*

- A. Owner and Contractor shall execute appropriate Change Orders pursuant to the Florida Department of Transportation (FDOT) Supplemental LAP Specifications. ~~recommended by Engineer covering:~~

- ~~1. changes in the Work which are: (i) ordered by Owner pursuant to Paragraph 10.01.A, (ii) required because of acceptance of defective Work under Paragraph 13.08.A or Owner's correction of defective Work under Paragraph 13.09, or (iii) agreed to by the parties;~~
- ~~2. changes in the Contract Price or Contract Times which are agreed to by the parties, including any undisputed sum or amount of time for Work actually performed in accordance with a Work Change Directive; and~~
- ~~3. changes in the Contract Price or Contract Times which embody the substance of any written decision rendered by Engineer pursuant to Paragraph 10.05; provided that, in lieu of executing any such Change Order, an appeal may be taken from any such decision in accordance with the provisions of the Contract Documents and applicable Laws and Regulations, but during any such appeal, Contractor shall carry on the Work and adhere to the Progress Schedule as provided in Paragraph 6.18.A.~~

10.04 Notification to Surety

- A. If the provisions of any bond require notice to be given to a surety of any change affecting the general scope of the Work or the provisions of the Contract Documents (including, but not limited to, Contract Price or Contract Times), the giving of any such notice will be Contractor's responsibility. The amount of each applicable bond will be adjusted to reflect the effect of any such change.

10.05 Claims

- A. ~~*Engineer's Decision Required:* All Claims, except those waived pursuant to Paragraph 14.09, shall be handled pursuant to the Florida Department of Transportation (FDOT) Supplement LAP Specifications, referred to the Engineer for decision. A decision by Engineer shall be required as a condition precedent to any exercise by Owner or Contractor of any rights or remedies either may otherwise have under the Contract Documents or by Laws and Regulations in respect of such Claims.~~
- B. ~~*Notice:* Written notice stating the general nature of each Claim shall be delivered by the claimant to Engineer and the other party to the Contract promptly (but in no event later than 30 15 days) after the start of the event giving rise thereto. The responsibility to substantiate a Claim shall rest with the party making the Claim. Notice of the amount or extent of the Claim, with supporting data shall be delivered to the Engineer and the other party to the Contract within 60 days after the start of such event (unless Engineer allows additional time for claimant to submit additional or more accurate data in support of such Claim). A Claim for an adjustment in Contract Price shall be prepared in accordance with the provisions of Paragraph 12.01.B. A Claim for an adjustment in Contract Times shall be prepared in accordance with the provisions of Paragraph 12.02.B. Each Claim shall be accompanied by claimant's written statement that the adjustment claimed is the entire adjustment to which the claimant believes it is entitled as a result of said event. The opposing party shall submit any response to Engineer and the claimant within 30 days after receipt of the claimant's last submittal (unless Engineer allows additional time). (see SC-10.05.B)~~
- C. ~~*Engineer's Action:* Engineer will review each Claim and, within 30 days after receipt of the last submittal of the claimant or the last submittal of the opposing party, if any, take one of the following actions in writing:~~

- ~~1. deny the Claim in whole or in part;~~
 - ~~2. approve the Claim; or~~
 - ~~3. notify the parties that the Engineer is unable to resolve the Claim if, in the Engineer's sole discretion, it would be inappropriate for the Engineer to do so. For purposes of further resolution of the Claim, such notice shall be deemed a denial.~~
- ~~D. In the event that Engineer does not take action on a Claim within said 30 days, the Claim shall be deemed denied.~~
- ~~E. Engineer's written action under Paragraph 10.05.C or denial pursuant to Paragraphs 10.05.C.3 or 10.05.D will be final and binding upon Owner and Contractor, unless Owner or Contractor invoke the dispute resolution procedure set forth in Article 16 within 30 days of such action or denial.~~
- ~~F. No Claim for an adjustment in Contract Price or Contract Times will be valid if not submitted in accordance with this Paragraph 10.05.~~

ARTICLE 11 – COST OF THE WORK; ALLOWANCES; UNIT PRICE WORK

11.01 Cost of the Work

- A. *Costs Included:* The term Cost of the Work means the sum of all costs, except those excluded in Paragraph 11.01.B, necessarily incurred and paid by Contractor in the proper performance of the Work. When the value of any Work covered by a Change Order or when a Claim for an adjustment in Contract Price is determined on the basis of Cost of the Work, the costs to be reimbursed to Contractor will be only those additional or incremental costs required because of the change in the Work or because of the event giving rise to the Claim. Except as otherwise may be agreed to in writing by Owner, such costs shall be in amounts no higher than those prevailing in the locality of the Project, shall not include any of the costs itemized in Paragraph 11.01.B, and shall include only the following items:
1. Payroll costs for employees in the direct employ of Contractor in the performance of the Work under schedules of job classifications agreed upon by Owner and Contractor. Such employees shall include, without limitation, superintendents, foremen, and other personnel employed full time on the Work. Payroll costs for employees not employed full time on the Work shall be apportioned on the basis of their time spent on the Work. Payroll costs shall include, but not be limited to, salaries and wages plus the cost of fringe benefits, which shall include social security contributions, unemployment, excise, and payroll taxes, workers' compensation, health and retirement benefits, bonuses, sick leave, vacation and holiday pay applicable thereto. The expenses of performing Work outside of regular working hours, on Saturday, Sunday, or legal holidays, shall be included in the above to the extent authorized by Owner.
 2. Cost of all materials and equipment furnished and incorporated in the Work, including costs of transportation and storage thereof, and Suppliers' field services required in connection therewith. All cash discounts shall accrue to Contractor unless Owner deposits funds with Contractor with which to make payments, in which case the cash discounts shall accrue to

Owner. All trade discounts, rebates and refunds and returns from sale of surplus materials and equipment shall accrue to Owner, and Contractor shall make provisions so that they may be obtained.

3. Payments made by Contractor to Subcontractors for Work performed by Subcontractors. If required by Owner, Contractor shall obtain competitive bids from subcontractors acceptable to Owner and Contractor and shall deliver such bids to Owner, who will then determine, with the advice of Engineer, which bids, if any, will be acceptable. If any subcontract provides that the Subcontractor is to be paid on the basis of Cost of the Work plus a fee, the Subcontractor's Cost of the Work and fee shall be determined in the same manner as Contractor's Cost of the Work and fee as provided in this Paragraph 11.01.
4. Costs of special consultants (including but not limited to engineers, architects, testing laboratories, surveyors, attorneys, and accountants) employed for services specifically related to the Work.
5. Supplemental costs including the following:
 - a. The proportion of necessary transportation, travel, and subsistence expenses of Contractor's employees incurred in discharge of duties connected with the Work.
 - b. Cost, including transportation and maintenance, of all materials, supplies, equipment, machinery, appliances, office, and temporary facilities at the Site, and hand tools not owned by the workers, which are consumed in the performance of the Work, and cost, less market value, of such items used but not consumed which remain the property of Contractor.
 - c. Rentals of all construction equipment and machinery, and the parts thereof whether rented from Contractor or others in accordance with rental agreements approved by Owner with the advice of Engineer, and the costs of transportation, loading, unloading, assembly, dismantling, and removal thereof. All such costs shall be in accordance with the terms of said rental agreements. The rental of any such equipment, machinery, or parts shall cease when the use thereof is no longer necessary for the Work. In no case shall rates exceed those published by the current edition of Data Quest Incorporated titled, Rental Rate Blue Book for Construction Equipment, and other procedures established by Florida Department of Transportation. (see SC-11.01.A.5.c)
 - d. Sales, consumer, use, and other similar taxes related to the Work, and for which Contractor is liable, as imposed by Laws and Regulations.
 - e. Deposits lost for causes other than negligence of Contractor, any Subcontractor, or anyone directly or indirectly employed by any of them or for whose acts any of them may be liable, and royalty payments and fees for permits and licenses.
 - f. Losses and damages (and related expenses) caused by damage to the Work, not compensated by insurance or otherwise, sustained by Contractor in connection with the performance of the Work (~~except losses and damages within the deductible amounts of property insurance established in accordance with Paragraph 5.06.D~~), provided such losses and damages have resulted from causes other than the negligence of Contractor,

any Subcontractor, or anyone directly or indirectly employed by any of them or for whose acts any of them may be liable. Such losses shall include settlements made with the written consent and approval of Owner. No such losses, damages, and expenses shall be included in the Cost of the Work for the purpose of determining Contractor's fee. (see SC-11.01.A.5.f)

- g. The cost of utilities, fuel, and sanitary facilities at the Site.
- h. Minor expenses such as telegrams, long distance telephone calls, telephone service at the Site, express and courier services, and similar petty cash items in connection with the Work.
- i. The costs of premiums for all bonds and insurance Contractor is required by the Contract Documents to purchase and maintain.
- j. The cost of specific consideration for the indemnifications set forth in paragraph 6.20. (see SC-11.01.A.5.j)
- k. The cost of compliance with current local, state and federal safety regulations. (see SC-11.01.A.5.k)

B. *Costs Excluded:* The term Cost of the Work shall not include any of the following items:

- 1. Payroll costs and other compensation of Contractor's officers, executives, principals (of partnerships and sole proprietorships), general managers, safety managers, engineers, architects, estimators, attorneys, auditors, accountants, purchasing and contracting agents, expeditors, timekeepers, clerks, and other personnel employed by Contractor, whether at the Site or in Contractor's principal or branch office for general administration of the Work and not specifically included in the agreed upon schedule of job classifications referred to in Paragraph 11.01.A.1 or specifically covered by Paragraph 11.01.A.4, all of which are to be considered administrative costs covered by the Contractor's fee.
- 2. Expenses of Contractor's principal and branch offices other than Contractor's office at the Site.
- 3. Any part of Contractor's capital expenses, including interest on Contractor's capital employed for the Work and charges against Contractor for delinquent payments.
- 4. Costs due to the negligence of Contractor, any Subcontractor, or anyone directly or indirectly employed by any of them or for whose acts any of them may be liable, including but not limited to, the correction of defective Work, disposal of materials or equipment wrongly supplied, and making good any damage to property.
- 5. Other overhead or general expense costs of any kind and the costs of any item not specifically and expressly included in Paragraphs 11.01.A.

C. *Contractor's Fee:* When all the Work is performed on the basis of cost-plus, Contractor's fee shall be determined as set forth in the Agreement. When the value of any Work covered by a

Change Order or when a Claim for an adjustment in Contract Price is determined on the basis of Cost of the Work, Contractor's fee shall be determined as set forth in Paragraph 12.01.C.

- D. *Documentation:* Whenever the Cost of the Work for any purpose is to be determined pursuant to Paragraphs 11.01.A and 11.01.B, Contractor will establish and maintain records thereof in accordance with generally accepted accounting practices and submit in a form acceptable to Engineer an itemized cost breakdown together with supporting data.

11.02 Allowances

- A. It is understood that Contractor has included in the Contract Price all allowances so named in the Contract Documents and shall cause the Work so covered to be performed for such sums and by such persons or entities as may be acceptable to Owner and Engineer.

B. *Cash Allowances:*

1. Contractor agrees that:

- a. the cash allowances include the cost to Contractor (less any applicable trade discounts) of materials and equipment required by the allowances to be delivered at the Site, and all applicable taxes; and
- b. Contractor's costs for unloading and handling on the Site, labor, installation, overhead, profit, and other expenses contemplated for the cash allowances have been included in the Contract Price and not in the allowances, and no demand for additional payment on account of any of the foregoing will be valid.

~~C. *Contingency Allowance:*~~

- ~~1. Contractor agrees that a contingency allowance, if any, is for the sole use of Owner to cover unanticipated costs.~~

- D. Prior to final payment, an appropriate Change Order will be issued as recommended by Engineer to reflect actual amounts due Contractor on account of Work covered by allowances, and the Contract Price shall be correspondingly adjusted.

11.03 Unit Price Work

- A. Where the Contract Documents provide that all or part of the Work is to be Unit Price Work, initially the Contract Price will be deemed to include for all Unit Price Work an amount equal to the sum of the unit price for each separately identified item of Unit Price Work times the estimated quantity of each item as indicated in the Agreement.
- B. The estimated quantities of items of Unit Price Work are not guaranteed and are solely for the purpose of comparison of Bids and determining an initial Contract Price. Determinations of the actual quantities and classifications of Unit Price Work performed by Contractor will be made by Engineer subject to the provisions of Paragraph 9.07.
- C. Each unit price will be deemed to include an amount considered by Contractor to be adequate to cover Contractor's overhead and profit for each separately identified item.

- D. Owner or Contractor may make a Claim for an adjustment in the Contract Price in accordance with Paragraph 10.05 if:
1. the quantity of any item of Unit Price Work performed by Contractor differs materially and significantly from the estimated quantity of such item indicated in the Agreement; and
 2. there is no corresponding adjustment with respect to any other item of Work; and
 3. Contractor believes that Contractor is entitled to an increase in Contract Price as a result of having incurred additional expense or Owner believes that Owner is entitled to a decrease in Contract Price and the parties are unable to agree as to the amount of any such increase or decrease.
- E. If Owner objects to Contractor's quoted adjustment in Unit Price Work set forth in paragraph 11.03.D, Owner may assign such work to its own forces or another contractor.
- F. Owner reserves the right to delete any Unit Price Work without financial penalty incurred from Contractor.

ARTICLE 12 – CHANGE OF CONTRACT PRICE; CHANGE OF CONTRACT TIMES

12.01 Change of Contract Price

- A. ~~The Contract Price may only be changed pursuant to the Florida Department of Transportation (FDOT) Supplement LAP Specifications by a Change Order. Any Claim for an adjustment in the Contract Price shall be based on written notice submitted by the party making the Claim to the Engineer and the other party to the Contract in accordance with the provisions of Paragraph 10.05.~~
- B. ~~The value of any Work covered by a Change Order or of any Claim for an adjustment in the Contract Price will be determined as follows:~~
1. ~~where the Work involved is covered by unit prices contained in the Contract Documents, by application of such unit prices to the quantities of the items involved (subject to the provisions of Paragraph 11.03); or~~
 2. ~~where the Work involved is not covered by unit prices contained in the Contract Documents, by a mutually agreed lump sum (which may include an allowance for overhead and profit not necessarily in accordance with Paragraph 12.01.C.2); or~~
 3. ~~where the Work involved is not covered by unit prices contained in the Contract Documents and agreement to a lump sum is not reached under Paragraph 12.01.B.2, on the basis of the Cost of the Work (determined as provided in Paragraph 11.01) plus a Contractor's fee for overhead and profit (determined as provided in Paragraph 12.01.C).~~
- C. *Contractor's Fee:* The Contractor's fee for overhead and profit shall be determined as follows:
1. a mutually acceptable fixed fee; or
 2. if a fixed fee is not agreed upon, then a fee based on the following percentages of the various portions of the Cost of the Work:

- a. for costs incurred under Paragraphs 11.01.A.1 and 11.01.A.2, the Contractor's fee shall be 15 percent;
- b. for costs incurred under Paragraph 11.01.A.3, the Contractor's fee shall be five percent;
- c. where one or more tiers of subcontracts are on the basis of Cost of the Work plus a fee and no fixed fee is agreed upon, the intent of Paragraphs 12.01.C.2.a and 12.01.C.2.b is that the Subcontractor who actually performs the Work, at whatever tier, will be paid a fee of 15 percent of the costs incurred by such Subcontractor under Paragraphs 11.01.A.1 and 11.01.A.2 and that any higher tier Subcontractor and Contractor will each be paid a fee of five percent of the amount paid to the next lower tier Subcontractor;
- d. no fee shall be payable on the basis of costs itemized under Paragraphs 11.01.A.4, 11.01.A.5, and 11.01.B;
- e. the amount of credit to be allowed by Contractor to Owner for any change which results in a net decrease in cost will be the amount of the actual net decrease in cost plus a deduction in Contractor's fee by an amount equal to five percent of such net decrease; and
- f. when both additions and credits are involved in any one change, the adjustment in Contractor's fee shall be computed on the basis of the net change in accordance with Paragraphs 12.01.C.2.a through 12.01.C.2.e, inclusive.
- g. Allowable cost for Rental equipment associated with extra work shall be in accordance with Section 4-3 of the of the LAP Supplemental Specifications. (see SC-12.01 C.2.g)

12.02 *Change of Contract Times*

- A. The Contract Times may only be changed pursuant to the Florida Department of Transportation (FDOT) Supplement LAP Specifications by a Change Order. Any Claim for an adjustment in the Contract Times shall be based on written notice submitted by the party making the Claim to the Engineer and the other party to the Contract in accordance with the provisions of Paragraph 10.05.
- ~~B. Any adjustment of the Contract Times covered by a Change Order or any Claim for an adjustment in the Contract Times will be determined in accordance with the provisions of this Article 12.~~
- C. On the 21st of each month, or the next following business day, the Contractor shall submit to the Owner and Engineer a request for weather days. Failure to submit the request forfeits the right to claim weather days for that period and any previous period. The Owner will grant time extensions, on a day for day basis, for delays caused by the effects of rains or other inclement weather conditions or related adverse soil conditions that prevent the Contractor from productively performing controlling items of work resulting in:
 - (1) The Contractor being unable to work at least 50% of the normal work day on pre-determined controlling work items due to adverse weather conditions.

No additional compensation will be made for delays caused by the effects of inclement weather.
(see SC-12.02.C)

12.03 Delays

- A. Where Contractor is prevented from completing any part of the Work within the Contract Times due to delay beyond the control of Contractor, the Contract Times will be extended in an amount equal to the time lost due to such delay if a Claim is made therefor as provided in Paragraph 12.02.A. Delays beyond the control of Contractor shall include, but not be limited to, acts or neglect by Owner, acts or neglect of utility owners or other contractors performing other work as contemplated by Article 7, fires, floods, epidemics, abnormal weather conditions, or acts of God.
- B. If Owner, Engineer, or other contractors or utility owners performing other work for Owner as contemplated by Article 7, or anyone for whom Owner is responsible, delays, disrupts, or interferes with the performance or progress of the Work, then Contractor shall be entitled to an equitable adjustment in the Contract Price or the Contract Times, or both. Contractor's entitlement to an adjustment of the Contract Times is conditioned on such adjustment being essential to Contractor's ability to complete the Work within the Contract Times.
- C. If Contractor is delayed in the performance or progress of the Work by fire, flood, epidemic, abnormal weather conditions, acts of God, acts or failures to act of utility owners not under the control of Owner, or other causes not the fault of and beyond control of Owner and Contractor, then Contractor shall be entitled to an equitable adjustment in Contract Times, if such adjustment is essential to Contractor's ability to complete the Work within the Contract Times. Such an adjustment shall be Contractor's sole and exclusive remedy for the delays described in this Paragraph 12.03.C.
- D. Owner, Engineer, and their officers, directors, members, partners, employees, agents, consultants, or subcontractors shall not be liable to Contractor for any claims, costs, losses, or damages (including but not limited to all fees and charges of engineers, architects, attorneys, and other professionals and all court or arbitration or other dispute resolution costs) sustained by Contractor on or in connection with any other project or anticipated project.
- E. Contractor shall not be entitled to an adjustment in Contract Price or Contract Times for delays within the control of Contractor. Delays attributable to and within the control of a Subcontractor or Supplier shall be deemed to be delays within the control of Contractor.

ARTICLE 13 – TESTS AND INSPECTIONS; CORRECTION, REMOVAL OR ACCEPTANCE OF DEFECTIVE WORK

13.01 Notice of Defects

- A. Prompt notice of all defective Work of which Owner or Engineer has actual knowledge will be given to Contractor. Defective Work may be rejected, corrected, or accepted as provided in this Article 13.

13.02 Access to Work

- A. Owner, Engineer, their consultants and other representatives and personnel of Owner, independent testing laboratories, and governmental agencies with jurisdictional interests will have access to the Site and the Work at reasonable times for their observation, inspection, and testing. Contractor shall provide them proper and safe conditions for such access and advise them of Contractor's safety procedures and programs so that they may comply therewith as applicable.

13.03 Tests and Inspections

- A. ~~Contractor shall refer to the Florida Department of Transportation (FDOT) Supplement LAP Specifications for all test and inspection requirements give Engineer timely notice of readiness of the Work for all required inspections, tests, or approvals and shall cooperate with inspection and testing personnel to facilitate required inspections or tests. Contractor shall reimburse Owner for the charges of Engineer and Engineer's Consultants for all costs due to work not being ready for tests and/or inspections when the Contractor has notified Engineer that work is ready for tests and/or inspections. Contractor shall reimburse Owner for all failed tests and subsequent retests. Reimbursement for the charges shall be a deduction from the Contractor's Partial Payment(s). (see SC 13.03.A)~~
- B. Owner shall employ and pay for the services of an independent testing laboratory to perform all inspections, tests, or approvals required by the Contract Documents except:
- ~~1. for inspections, tests, or approvals covered by Paragraphs 13.03.C and 13.03.D below;~~
 - ~~2. that costs incurred in connection with tests or inspections conducted pursuant to Paragraph 13.04.B shall be paid as provided in Paragraph 13.04.C; and~~
 - ~~3. as otherwise specifically provided in the Contract Documents.~~
- B. ~~The Contractor shall obtain and employ an independent testing laboratory to provide the services specified herein and shall include all costs for these services in the contract price. The Contractor shall submit for approval by the Owner and Engineer, the independent testing laboratory, including qualifications.~~
- ~~Copies of all testing agency invoices submitted to the Contractor for payment shall be forwarded with the Contractor's request for partial payment. Invoices shall be submitted routinely throughout the project and shall be pertinent to the partial payment period under consideration. Testing agency invoices in excess of sixty (60) days old shall not be considered for payment. Invoices shall clearly indicate type and amount of test performed, unit and total cost, and shall indicate if the invoiced testing cost is a result of retests required due to the Contractor's failure to achieve specified requirements. The cost of retesting due to test failure will be borne by the Contractor. Payment to Contractor for testing shall not be made without the required itemized invoicing. (see SC 13.03.B)~~
- C. ~~If Laws or Regulations of any public body having jurisdiction require any Work (or part thereof) specifically to be inspected, tested, or approved by an employee or other representative of such public body, Contractor shall assume full responsibility for arranging and obtaining such~~

~~inspections, tests, or approvals, pay all costs in connection therewith, and furnish Engineer the required certificates of inspection or approval.~~

- ~~D. Contractor shall be responsible for arranging and obtaining and shall pay all costs in connection with any inspections, tests, or approvals required for Owner's and Engineer's acceptance of materials or equipment to be incorporated in the Work; or acceptance of materials, mix designs, or equipment submitted for approval prior to Contractor's purchase thereof for incorporation in the Work. Such inspections, tests, or approvals shall be performed by organizations acceptable to Owner and Engineer.~~
- ~~E. If any Work (or the work of others) that is to be inspected, tested, or approved is covered by Contractor without written concurrence of Engineer, Contractor shall, if requested by Engineer, uncover such Work for observation.~~
- ~~F. Uncovering Work as provided in Paragraph 13.03.E shall be at Contractor's expense unless Contractor has given Engineer timely notice of Contractor's intention to cover the same and Engineer has not acted with reasonable promptness in response to such notice.~~

13.04 *Uncovering Work*

- A. If any Work is covered contrary to the written request of Engineer, it must, if requested by Engineer, be uncovered for Engineer's observation and replaced at Contractor's expense.
- B. If Engineer considers it necessary or advisable that covered Work be observed by Engineer or inspected or tested by others, Contractor, at Engineer's request, shall uncover, expose, or otherwise make available for observation, inspection, or testing as Engineer may require, that portion of the Work in question, furnishing all necessary labor, material, and equipment.
- C. If it is found that the uncovered Work is defective, Contractor shall pay all claims, costs, losses, and damages (including but not limited to all fees and charges of engineers, architects, attorneys, and other professionals and all court or arbitration or other dispute resolution costs) arising out of or relating to such uncovering, exposure, observation, inspection, and testing, and of satisfactory replacement or reconstruction (including but not limited to all costs of repair or replacement of work of others); and Owner shall be entitled to an appropriate decrease in the Contract Price. If the parties are unable to agree as to the amount thereof, Owner may make a Claim therefor as provided in Paragraph 10.05.
- D. If the uncovered Work is not found to be defective, Contractor shall be allowed an increase in the Contract Price or an extension of the Contract Times, or both, directly attributable to such uncovering, exposure, observation, inspection, testing, replacement, and reconstruction. If the parties are unable to agree as to the amount or extent thereof, Contractor may make a Claim therefor as provided in Paragraph 10.05.

13.05 *Owner May Stop the Work*

- A. If the Work is defective, or Contractor fails to supply sufficient skilled workers or suitable materials or equipment, or fails to perform the Work in such a way that the completed Work will conform to the Contract Documents, Owner may order Contractor to stop the Work, or any portion thereof, until the cause for such order has been eliminated; however, this right of Owner

to stop the Work shall not give rise to any duty on the part of Owner to exercise this right for the benefit of Contractor, any Subcontractor, any Supplier, any other individual or entity, or any surety for, or employee or agent of any of them.

13.06 Correction or Removal of Defective Work

- A. Promptly after receipt of written notice, Contractor shall correct all defective Work, whether or not fabricated, installed, or completed, or, if the Work has been rejected by Engineer, remove it from the Project and replace it with Work that is not defective. Contractor shall pay all claims, costs, losses, and damages (including but not limited to all fees and charges of engineers, architects, attorneys, and other professionals and all court or arbitration or other dispute resolution costs) arising out of or relating to such correction or removal (including but not limited to all costs of repair or replacement of work of others).
- B. When correcting defective Work under the terms of this Paragraph 13.06 or Paragraph 13.07, Contractor shall take no action that would void or otherwise impair Owner's special warranty and guarantee, if any, on said Work.

13.07 Correction Period

- A. If within one year after the date of Substantial Completion (or such longer period of time as may be prescribed by the terms of any applicable special guarantee required by the Contract Documents) or by any specific provision of the Contract Documents, any Work is found to be defective, or if the repair of any damages to the land or areas made available for Contractor's use by Owner or permitted by Laws and Regulations as contemplated in Paragraph 6.11.A is found to be defective, Contractor shall promptly, without cost to Owner and in accordance with Owner's written instructions:
 - 1. repair such defective land or areas; or
 - 2. correct such defective Work; or
 - 3. if the defective Work has been rejected by Owner, remove it from the Project and replace it with Work that is not defective, and
 - 4. satisfactorily correct or repair or remove and replace any damage to other Work, to the work of others or other land or areas resulting therefrom.
- B. If Contractor does not promptly comply with the terms of Owner's written instructions, or in an emergency where delay would cause serious risk of loss or damage, Owner may have the defective Work corrected or repaired or may have the rejected Work removed and replaced. All claims, costs, losses, and damages (including but not limited to all fees and charges of engineers, architects, attorneys, and other professionals and all court or arbitration or other dispute resolution costs) arising out of or relating to such correction or repair or such removal and replacement (including but not limited to all costs of repair or replacement of work of others) will be paid by Contractor.

- ~~4. Neither Engineer's review of Contractor's Work for the purposes of recommending payments nor Engineer's recommendation of any payment, including final payment, will impose responsibility on Engineer:~~
- ~~a. to supervise, direct, or control the Work, or~~
 - ~~b. for the means, methods, techniques, sequences, or procedures of construction, or the safety precautions and programs incident thereto, or~~
 - ~~c. for Contractor's failure to comply with Laws and Regulations applicable to Contractor's performance of the Work, or~~
 - ~~d. to make any examination to ascertain how or for what purposes Contractor has used the moneys paid on account of the Contract Price, or~~
 - ~~e. to determine that title to any of the Work, materials, or equipment has passed to Owner free and clear of any Liens.~~
- ~~5. Engineer may refuse to recommend the whole or any part of any payment if, in Engineer's opinion, it would be incorrect to make the representations to Owner stated in Paragraph 14.02.B.2. Engineer may also refuse to recommend any such payment or, because of subsequently discovered evidence or the results of subsequent inspections or tests, revise or revoke any such payment recommendation previously made, to such extent as may be necessary in Engineer's opinion to protect Owner from loss because:~~
- ~~a. the Work is defective, or completed Work has been damaged, requiring correction or replacement;~~
 - ~~b. the Contract Price has been reduced by Change Orders;~~
 - ~~c. Owner has been required to correct defective Work or complete Work in accordance with Paragraph 13.09; or~~
 - ~~d. Engineer has actual knowledge of the occurrence of any of the events enumerated in Paragraph 15.02.A.~~

~~C. Payment Becomes Due:~~

- ~~1. Ten days after presentation of the Application for Payment to Owner with Engineer's recommendation, the amount recommended will (subject to the provisions of Paragraph 14.02.D) become due, and when due will be paid by Owner to Contractor.~~

~~D. Reduction in Payment:~~

- ~~1. Owner may refuse to make payment of the full amount recommended by Engineer because:~~
- ~~a. claims have been made against Owner on account of Contractor's performance or furnishing of the Work;~~

- ~~b. Liens have been filed in connection with the Work, except where Contractor has delivered a specific bond satisfactory to Owner to secure the satisfaction and discharge of such Liens;~~
 - ~~e. there are other items entitling Owner to a set-off against the amount recommended; or~~
 - ~~d. Owner has actual knowledge of the occurrence of any of the events enumerated in Paragraphs 14.02.B.5.a through 14.02.B.5.e or Paragraph 15.02.A.~~
- ~~2. If Owner refuses to make payment of the full amount recommended by Engineer, Owner will give Contractor immediate written notice (with a copy to Engineer) stating the reasons for such action and promptly pay Contractor any amount remaining after deduction of the amount so withheld. Owner shall promptly pay Contractor the amount so withheld, or any adjustment thereto agreed to by Owner and Contractor, when Contractor remedies the reasons for such action.~~
- ~~3. Upon a subsequent determination that Owner's refusal of payment was not justified, the amount wrongfully withheld shall be treated as an amount due as determined by Paragraph 14.02.C.1 and subject to interest as provided in the Agreement.~~

14.03 Contractor's Warranty of Title

- A. Contractor warrants and guarantees that title to all Work, materials, and equipment covered by any Application for Payment, whether incorporated in the Project or not, will pass to Owner no later than the time of payment free and clear of all Liens.

14.04 Substantial Completion

- A. When Contractor considers the entire Work ready for its intended use Contractor shall notify Owner and Engineer in writing that the entire Work is substantially complete (except for items specifically listed by Contractor as incomplete) and request that Engineer issue a certificate of Substantial Completion.
- B. Promptly after Contractor's notification, Owner, Contractor, and Engineer shall make an inspection of the Work to determine the status of completion. If Engineer does not consider the Work substantially complete, Engineer will notify Contractor in writing giving the reasons therefor.
- C. If Engineer considers the Work substantially complete, Engineer will deliver to Owner a tentative certificate of Substantial Completion which shall fix the date of Substantial Completion. There shall be attached to the certificate a tentative list of items to be completed or corrected before final payment. Owner shall have seven days after receipt of the tentative certificate during which to make written objection to Engineer as to any provisions of the certificate or attached list. If, after considering such objections, Engineer concludes that the Work is not substantially complete, Engineer will, within 14 days after submission of the tentative certificate to Owner, notify Contractor in writing, stating the reasons therefor. If, after consideration of Owner's objections, Engineer considers the Work substantially complete, Engineer will, within said 14 days, execute and deliver to Owner and Contractor a definitive certificate of Substantial Completion (with a revised tentative list of items to be completed or

corrected) reflecting such changes from the tentative certificate as Engineer believes justified after consideration of any objections from Owner.

- D. At the time of delivery of the tentative certificate of Substantial Completion, Engineer will deliver to Owner and Contractor a written recommendation as to division of responsibilities pending final payment between Owner and Contractor with respect to security, operation, safety, and protection of the Work, maintenance, heat, utilities, insurance, and warranties and guarantees. Unless Owner and Contractor agree otherwise in writing and so inform Engineer in writing prior to Engineer's issuing the definitive certificate of Substantial Completion, Engineer's aforesaid recommendation will be binding on Owner and Contractor until final payment.
- E. Owner shall have the right to exclude Contractor from the Site after the date of Substantial Completion subject to allowing Contractor reasonable access to remove its property and complete or correct items on the tentative list.

14.05 Partial Utilization

- A. Prior to Substantial Completion of all the Work, Owner may use or occupy any substantially completed part of the Work which has specifically been identified in the Contract Documents, or which Owner, Engineer, and Contractor agree constitutes a separately functioning and usable part of the Work that can be used by Owner for its intended purpose without significant interference with Contractor's performance of the remainder of the Work, subject to the following conditions:
 - 1. Owner at any time may request Contractor in writing to permit Owner to use or occupy any such part of the Work which Owner believes to be ready for its intended use and substantially complete. If and when Contractor agrees that such part of the Work is substantially complete, Contractor, Owner, and Engineer will follow the procedures of Paragraph 14.04.A through D for that part of the Work.
 - 2. Contractor at any time may notify Owner and Engineer in writing that Contractor considers any such part of the Work ready for its intended use and substantially complete and request Engineer to issue a certificate of Substantial Completion for that part of the Work.
 - 3. Within a reasonable time after either such request, Owner, Contractor, and Engineer shall make an inspection of that part of the Work to determine its status of completion. If Engineer does not consider that part of the Work to be substantially complete, Engineer will notify Owner and Contractor in writing giving the reasons therefor. If Engineer considers that part of the Work to be substantially complete, the provisions of Paragraph 14.04 will apply with respect to certification of Substantial Completion of that part of the Work and the division of responsibility in respect thereof and access thereto.
 - 4. ~~No use or occupancy or separate operation of part of the Work may occur prior to compliance with the requirements of Paragraph 5.10 regarding property insurance. (see SC.14.5.A.4)~~

14.06 Final Inspection

- A. Upon written notice from Contractor that the entire Work or an agreed portion thereof is complete, Engineer will promptly make a final inspection with Owner and Contractor and will notify Contractor in writing of all particulars in which this inspection reveals that the Work is incomplete or defective. Contractor shall immediately take such measures as are necessary to complete such Work or remedy such deficiencies.

14.07 Final Payment

- A. Contractor shall refer to the Florida Department of Transportation (FDOT) Supplement LAP Specifications for Final Payment requirements *Application for Payment*:

- ~~1. After Contractor has, in the opinion of Engineer, satisfactorily completed all corrections identified during the final inspection and has delivered, in accordance with the Contract Documents, all maintenance and operating instructions, schedules, guarantees, bonds, certificates or other evidence of insurance, certificates of inspection, marked-up record documents (as provided in Paragraph 6.12), and other documents, Contractor may make application for final payment following the procedure for progress payments.~~
- ~~2. The final Application for Payment shall be accompanied (except as previously delivered) by:

 - ~~a. all documentation called for in the Contract Documents, including but not limited to the evidence of insurance required by Paragraph 5.04.B.6;~~
 - ~~b. consent of the surety, if any, to final payment;~~
 - ~~c. a list of all Claims against Owner that Contractor believes are unsettled; and~~
 - ~~d. complete and legally effective releases or waivers (satisfactory to Owner) of all Lien rights arising out of or Liens filed in connection with the Work.~~~~
- ~~3. In lieu of the releases or waivers of Liens specified in Paragraph 14.07.A.2 and as approved by Owner, Contractor may furnish receipts or releases in full and an affidavit of Contractor that: (i) the releases and receipts include all labor, services, material, and equipment for which a Lien could be filed; and (ii) all payrolls, material and equipment bills, and other indebtedness connected with the Work for which Owner might in any way be responsible, or which might in any way result in liens or other burdens on Owner's property, have been paid or otherwise satisfied. If any Subcontractor or Supplier fails to furnish such a release or receipt in full, Contractor may furnish a bond or other collateral satisfactory to Owner to indemnify Owner against any Lien.~~

- ~~B. *Engineer's Review of Application and Acceptance:*~~

- ~~1. If, on the basis of Engineer's observation of the Work during construction and final inspection, and Engineer's review of the final Application for Payment and accompanying documentation as required by the Contract Documents, Engineer is satisfied that the Work has been completed and Contractor's other obligations under the Contract Documents have been fulfilled, Engineer will, within ten days after receipt of the final Application for Payment, indicate in writing Engineer's recommendation of payment and present the~~

~~Application for Payment to Owner for payment. At the same time Engineer will also give written notice to Owner and Contractor that the Work is acceptable subject to the provisions of Paragraph 14.09. Otherwise, Engineer will return the Application for Payment to Contractor, indicating in writing the reasons for refusing to recommend final payment, in which case Contractor shall make the necessary corrections and resubmit the Application for Payment.~~

~~C. Payment Becomes Due:~~

- ~~1. Thirty days after the presentation to Owner of the Application for Payment and accompanying documentation, the amount recommended by Engineer, less any sum Owner is entitled to set off against Engineer's recommendation, including but not limited to liquidated damages, will become due and will be paid by Owner to Contractor.~~

14.08 *Final Completion Delayed*

- A. If, through no fault of Contractor, final completion of the Work is significantly delayed, and if Engineer so confirms, Owner shall, upon receipt of Contractor's final Application for Payment (for Work fully completed and accepted) and recommendation of Engineer, and without terminating the Contract, make payment of the balance due for that portion of the Work fully completed and accepted. If the remaining balance to be held by Owner for Work not fully completed or corrected is less than the retainage stipulated in the Agreement, and if bonds have been furnished as required in Paragraph 5.01, the written consent of the surety to the payment of the balance due for that portion of the Work fully completed and accepted shall be submitted by Contractor to Engineer with the Application for such payment. Such payment shall be made under the terms and conditions governing final payment, except that it shall not constitute a waiver of Claims.

14.09 *Waiver of Claims*

- A. The making and acceptance of final payment will be pursuant to the Florida Department of Transportation (FDOT) Supplement LAP Specifications constitute:

- ~~1. a waiver of all Claims by Owner against Contractor, except Claims arising from unsettled Liens, from defective Work appearing after final inspection pursuant to Paragraph 14.06, from failure to comply with the Contract Documents or the terms of any special guarantees specified therein, or whenever said failure occurs from Contractor's continuing obligations under the Contract Documents; and (see SC-14.09.A.1)~~
- ~~2. a waiver of all Claims by Contractor against Owner other than those previously made in accordance with the requirements herein and expressly acknowledged by Owner in writing as still unsettled.~~
- ~~3. The acceptance of final payment by Contractor designated and identified by Engineer as final payment shall be and shall operate as a release to Owner of all claims and all liability to Contractor other than claims in stated amounts as may be specifically excepted by Contractor for all things done or finished in connection with the Work and for every act of Owner and others relating to or arising out of the Work. Any payment, however, final or otherwise, shall not release Contractor or Contractor's Surety(ies) from any obligations under the Contract Documents or Bonds. (see SC-14.09.A.3)~~

ARTICLE 15 – SUSPENSION OF WORK AND TERMINATION~~15.01 Owner May Suspend Work~~

~~A. At any time and without cause, Owner may suspend the Work or any portion thereof for a period of not more than 90 consecutive days by notice in writing to Contractor and Engineer which will fix the date on which Work will be resumed. Contractor shall resume the Work on the date so fixed. Contractor shall be granted an adjustment in the Contract Price or an extension of the Contract Times, or both, directly attributable to any such suspension if Contractor makes a Claim therefor as provided in Paragraph 10.05.~~

15.02 Owner May Terminate for Cause

- A. The occurrence of any one or more of the following events will justify termination for cause:
1. Contractor's start the work in accordance with the Notice to Proceed or Contractor's persistent failure to perform the Work in accordance with the Contract Documents (including, but not limited to, failure to supply sufficient skilled workers or suitable materials or equipment or failure to adhere to the Progress Schedule established under Paragraph 2.07 as adjusted from time to time pursuant to Paragraph 6.04) (see SC-15.02.A.1);
 2. Contractor's disregard of Laws or Regulations of any public body having jurisdiction;
 3. Contractor's repeated disregard of the authority of Engineer; or
 4. Contractor's violation in any substantial way of any provisions of the Contract Documents.
- B. If one or more of the events identified in Paragraph 15.02.A occur, Owner may, after giving Contractor (and surety) seven days written notice of its intent to terminate the services of Contractor:
1. exclude Contractor from the Site, and take possession of the Work and of all Contractor's tools, appliances, construction equipment, and machinery at the Site, and use the same to the full extent they could be used by Contractor (without liability to Contractor for trespass or conversion);
 2. incorporate in the Work all materials and equipment stored at the Site or for which Owner has paid Contractor but which are stored elsewhere; and
 3. complete the Work as Owner may deem expedient.
- C. If Owner proceeds as provided in Paragraph 15.02.B, Contractor shall not be entitled to receive any further payment until the Work is completed. If the unpaid balance of the Contract Price exceeds all claims, costs, losses, and damages (including but not limited to all fees and charges of engineers, architects, attorneys, and other professionals and all court or arbitration or other dispute resolution costs) sustained by Owner arising out of or relating to completing the Work, such excess will be paid to Contractor. If such claims, costs, losses, and damages exceed such unpaid balance, Contractor shall pay the difference to Owner. Such claims, costs, losses, and damages incurred by Owner will be reviewed by Engineer as to their reasonableness and, when

so approved by Engineer, incorporated in a Change Order. When exercising any rights or remedies under this Paragraph, Owner shall not be required to obtain the lowest price for the Work performed.

- D. Notwithstanding Paragraphs 15.02.B and 15.02.C, Contractor's services will not be terminated if Contractor begins within seven days of receipt of notice of intent to terminate to correct its failure to perform and proceeds diligently to cure such failure within no more than 30 days of receipt of said notice.
- E. Where Contractor's services have been so terminated by Owner, the termination will not affect any rights or remedies of Owner against Contractor then existing or which may thereafter accrue. Any retention or payment of moneys due Contractor by Owner will not release Contractor from liability.
- F. If and to the extent that Contractor has provided a performance bond under the provisions of Paragraph 5.01.A, the termination procedures of that bond shall supersede the provisions of Paragraphs 15.02.B and 15.02.C.

15.03 Owner May Terminate For Convenience

- A. Upon seven days written notice to Contractor and Engineer, Owner may, without cause and without prejudice to any other right or remedy of Owner, terminate the Contract. In such case, Contractor shall be paid for (without duplication of any items):
 - 1. completed and acceptable Work executed in accordance with the Contract Documents prior to the effective date of termination, including fair and reasonable sums for overhead and profit on such Work;
 - 2. expenses sustained prior to the effective date of termination in performing services and furnishing labor, materials, or equipment as required by the Contract Documents in connection with uncompleted Work, plus fair and reasonable sums for overhead and profit on such expenses;
 - 3. all claims, costs, losses, and damages (including but not limited to all fees and charges of engineers, architects, attorneys, and other professionals and all court or arbitration or other dispute resolution costs) incurred in settlement of terminated contracts with Subcontractors, Suppliers, and others; and
 - 4. reasonable expenses directly attributable to termination.
- B. Contractor shall not be paid on account of loss of anticipated profits or revenue or other economic loss arising out of or resulting from such termination.

15.04 Contractor May Stop Work or Terminate

- A. If, through no act or fault of Contractor, (i) the Work is suspended for more than 90 consecutive days by Owner or under an order of court or other public authority, or (ii) Engineer fails to act on any Application for Payment within 30 days after it is submitted, or (iii) Owner fails for 30 days to pay Contractor any sum finally determined to be due, then Contractor may, upon seven days

written notice to Owner and Engineer, and provided Owner or Engineer do not remedy such suspension or failure within that time, terminate the Contract and recover from Owner payment on the same terms as provided in Paragraph 15.03.

- B. In lieu of terminating the Contract and without prejudice to any other right or remedy, if Engineer has failed to act on an Application for Payment within 30 days after it is submitted, or Owner has failed for 30 days to pay Contractor any sum finally determined to be due, Contractor may, seven days after written notice to Owner and Engineer, stop the Work until payment is made of all such amounts due Contractor, including interest thereon. The provisions of this Paragraph 15.04 are not intended to preclude Contractor from making a Claim under Paragraph 10.05 for an adjustment in Contract Price or Contract Times or otherwise for expenses or damage directly attributable to Contractor's stopping the Work as permitted by this Paragraph.

ARTICLE 16 – DISPUTE RESOLUTION

16.01 *Methods and Procedures*

- A. Either Owner or Contractor may request mediation of any Claim submitted to Engineer for a decision under Paragraph 10.05 before such decision becomes final and binding. The mediation will be governed by the Construction Industry Mediation Rules of the American Arbitration Association in effect as of the Effective Date of the Agreement. The request for mediation shall be submitted in writing to the American Arbitration Association and the other party to the Contract. Timely submission of the request shall stay the effect of Paragraph 10.05.E.
- B. Owner and Contractor shall participate in the mediation process in good faith. The process shall be concluded within 60 days of filing of the request. The date of termination of the mediation shall be determined by application of the mediation rules referenced above.
- C. If the Claim is not resolved by mediation, Engineer's action under Paragraph 10.05.C or a denial pursuant to Paragraphs 10.05.C.3 or 10.05.D shall become final and binding 30 days after termination of the mediation unless, within that time period, Owner or Contractor:
1. elects in writing to invoke any dispute resolution process provided for in the Supplementary Conditions; or
 2. agrees with the other party to submit the Claim to another dispute resolution process; or
 3. gives written notice to the other party of the intent to submit the Claim to a court of competent jurisdiction.
- D. Venue for any mediation shall be in Nassau County, Florida. Venue for any litigation shall be in state court in Nassau County, Florida.

ARTICLE 17 – MISCELLANEOUS

17.01 *Giving Notice*

- A. Whenever any provision of the Contract Documents requires the giving of written notice, it will be deemed to have been validly given if:

1. delivered in person to the individual or to a member of the firm or to an officer of the corporation for whom it is intended; or
2. delivered at or sent by registered or certified mail, postage prepaid, to the last business address known to the giver of the notice.

17.02 Computation of Times

- A. When any period of time is referred to in the Contract Documents by days, it will be computed to exclude the first and include the last day of such period. If the last day of any such period falls on a Saturday or Sunday or on a day made a legal holiday by the law of the applicable jurisdiction, such day will be omitted from the computation.

17.03 Cumulative Remedies

- A. The duties and obligations imposed by these General Conditions and the rights and remedies available hereunder to the parties hereto are in addition to, and are not to be construed in any way as a limitation of, any rights and remedies available to any or all of them which are otherwise imposed or available by Laws or Regulations, by special warranty or guarantee, or by other provisions of the Contract Documents. The provisions of this Paragraph will be as effective as if repeated specifically in the Contract Documents in connection with each particular duty, obligation, right, and remedy to which they apply.

17.04 Survival of Obligations

- A. All representations, indemnifications, warranties, and guarantees made in, required by, or given in accordance with the Contract Documents, as well as all continuing obligations indicated in the Contract Documents, will survive final payment, completion, and acceptance of the Work or termination or completion of the Contract or termination of the services of Contractor.

17.05 Controlling Law

- A. This Contract is to be governed by the law of the state in which the Project is located.

17.06 Headings

- A. Article and paragraph headings are inserted for convenience only and do not constitute parts of these General Conditions.

SECTION 00 73 15**SUPPLEMENTARY CONDITIONS**

These Supplementary Conditions amend or supplement the Standard General Conditions of the Construction Contract (EJCDC C-700, 2007 Edition). All provisions which are not so amended or supplemented remain in full force and effect.

The terms used in these Supplementary Conditions which are defined in the Standard General Conditions of the Construction Contract have the meanings assigned to them in the General Conditions.

Local Agency Program Agreement 439496-1-58-01**Section 14.f**

Neither the Recipient nor any of its contractors or their subcontractors shall enter into any contract, subcontract or arrangement in connection with the Project or any property included or planned to be included in the Project in which any member, officer or employee of the Recipient or the locality during tenure or for 2 years thereafter has any interest, direct or indirect. If any such present or former member, officer or employee involuntarily acquires or had acquired prior to the beginning of tenure any such interest, and if such interest is immediately disclosed to the Recipient, the Recipient, with prior approval of the Department, may waive the prohibition contained in this paragraph provided that any such present member, officer or employee shall not participate in any action by the Recipient or the locality relating to such contract, subcontract or arrangement. The Recipient shall insert in all contracts entered into in connection with the Project or any property included or planned to be included in any Project, and shall require its contractors to insert in each of their subcontracts, the following provision:

"No member, officer or employee of the Recipient or of the locality during his tenure or for 2 years thereafter shall have any interest, direct or indirect, in this contract or the proceeds thereof."

The provisions of this paragraph shall not be applicable to any agreement between the Recipient and its fiscal depositories or to any agreement for utility services the rates for which are fixed or controlled by a governmental agency.

Local Agency Program Agreement 439496-1-58-01**Section 15.c**

Recipient agrees to include the following indemnification in all contracts with contractors, subcontractors, consultants, or subconsultants (each referred to as "Entity" for the purposes of the below indemnification) who perform work in connection with this Agreement:

"To the extent provided by law, [ENTITY] shall indemnify, defend, and hold harmless the

[RECIPIENT] and the State of Florida, Department of Transportation, Including the Department's officers, agents, and employees, against any actions, claims, or damages arising out of, relating to, or resulting from negligent or wrongful act(s) of [ENTITY], or any of its officers, agents, or employees, acting within the scope of their office or employment, in connection with the rights granted to or exercised by [ENTITY] hereunder, to the extent and within the limitations of Section 768.28, Florida Statutes.

The foregoing indemnification shall not constitute a waiver of sovereign Immunity beyond the limits set forth in Florida Statutes, Section 768.28. Nor shall the same be construed to constitute agreement by [ENTITY] to indemnify [RECIPIENT] for the negligent acts or omissions of [RECIPIENT], its officers, agents, or employees, or third parties. Nor shall the same be construed to constitute agreement by [ENTITY] to indemnify the Department for the negligent acts or omissions of the Department, its officers, agents, or employees, or third parties. This Indemnification shall survive the termination of this Agreement.”

Local Agency Program Agreement 439496-1-58-01

Section 17.o

The Parties agree to comply with s.20.055(5), Florida Statutes, and to Incorporate in all subcontracts the obligation to comply with s.20.055(5), Florida Statutes.

D. PLANS AND TECHNICAL
SPECIFICATIONS

CONTRACT PLANS COMPONENTS
SIGNING AND PAVEMENT MARKING PLANS

INDEX OF SIGNING AND PAVEMENT MARKING PLANS

SHEET NO.	SHEET DESCRIPTION
S-1	KEY SHEET
S-2	KEY MAP SHEET
S-3	SIGNATURE SHEET
S-4 - S-7	TABULATION OF QUANTITIES
S-8	GENERAL NOTES
S-9 - S-44	SIGNING AND PAVEMENT MARKING PLAN
S-45	TEMPORARY TRAFFIC CONTROL PLAN
SQ-1 TO SQ-2	SUMMARY OF QUANTITIES

STATE OF FLORIDA
DEPARTMENT OF TRANSPORTATION

CONTRACT PLANS

FINANCIAL PROJECT ID 441217-1-52-01

NASSAU COUNTY (74000021, 74000033,
74150500, 74530, 74550 & 74600)

COUNTY ROAD NO. 121
S 14TH STREET
CHESTER ROAD
SADLER ROAD
AMELIA CONCOURSE

SIGNING AND PAVEMENT MARKING PLANS

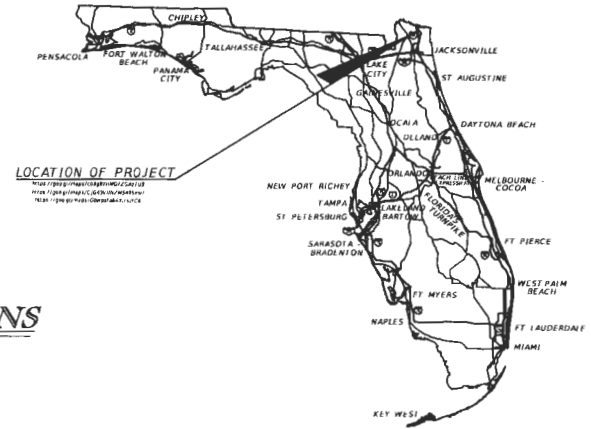

SEE SHEET S-2 FOR KEY MAP

SIGNING AND PAVEMENT MARKING PLANS
ENGINEER OF RECORD:

ERNEST LEE HERBERT IV, P.E. NO. 79413
COMPREHENSIVE ENGINEERING SERVICES, INC.
201 S. ORANGE AVENUE, SUITE 1300
ORLANDO, FL 32801
Phone: (407) 423-1600
Fax: (407) 423-9614
VENDOR NO. F59347222001
CONTRACT NO. C-9J15

FDOT PROJECT MANAGER:
RENEE BRINKLEY

GOVERNING STANDARD PLANS:

Florida Department of Transportation, FY 2020-21 Standard Plans for Road and Bridge Construction and applicable Interim Revisions (IRs).

Standard Plans for Road Construction and associated IRs are available at the following website: <http://www.fdot.gov/design/standardplans>

GOVERNING STANDARD SPECIFICATIONS:

Florida Department of Transportation, July 2020 Standard Specifications for Road and Bridge Construction at the following website: <http://www.fdot.gov/programmanagement/implemented/specbooks>

CONSTRUCTION CONTRACT NO.	FISCAL YEAR	SHEET NO.
C-9773	21	S-1

Contract No. CM3150
BIG BOX 02/21/2021
THIS SHEET IS THE ELECTRONIC FILE DIGITALLY SIGNED AND SEALED UNDER RULE 61G15-23.004, F.A.C.

NASSAU COUNTY (74550)

CR 121
LOCATION I

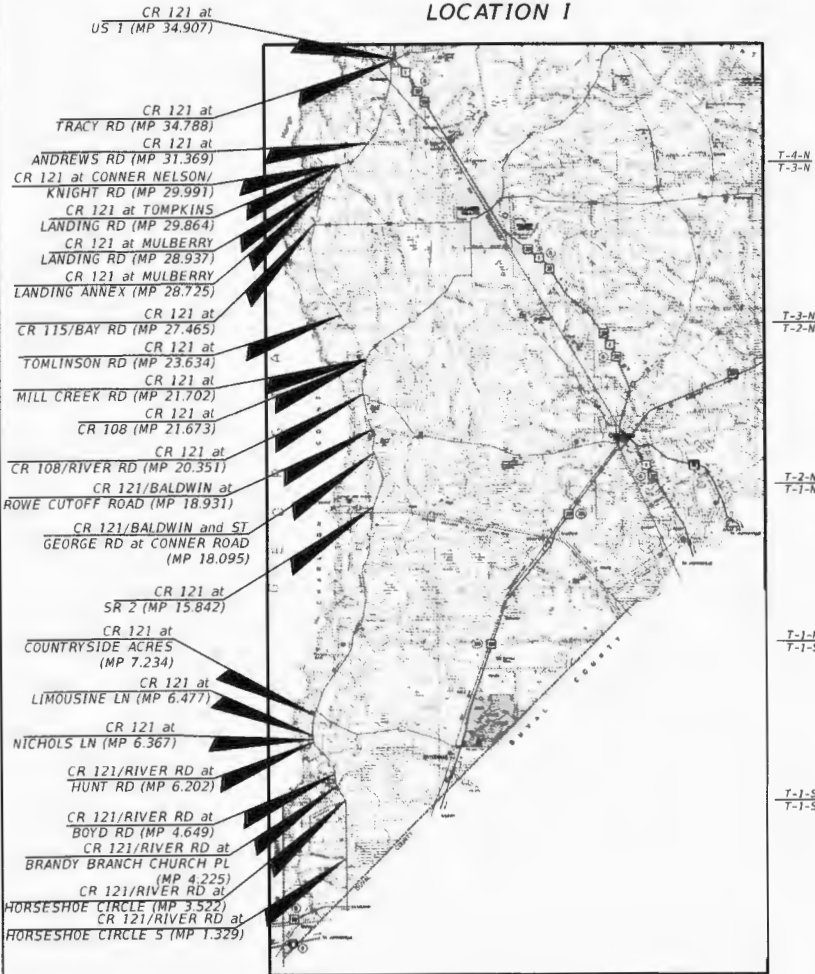

NASSAU COUNTY (74000021, 74000033,
74150500, 74530 & 74600)

S 14TH ST, CHESTER ROAD,
SADLER ROAD & AMELIA CONCOURSE
LOCATION II

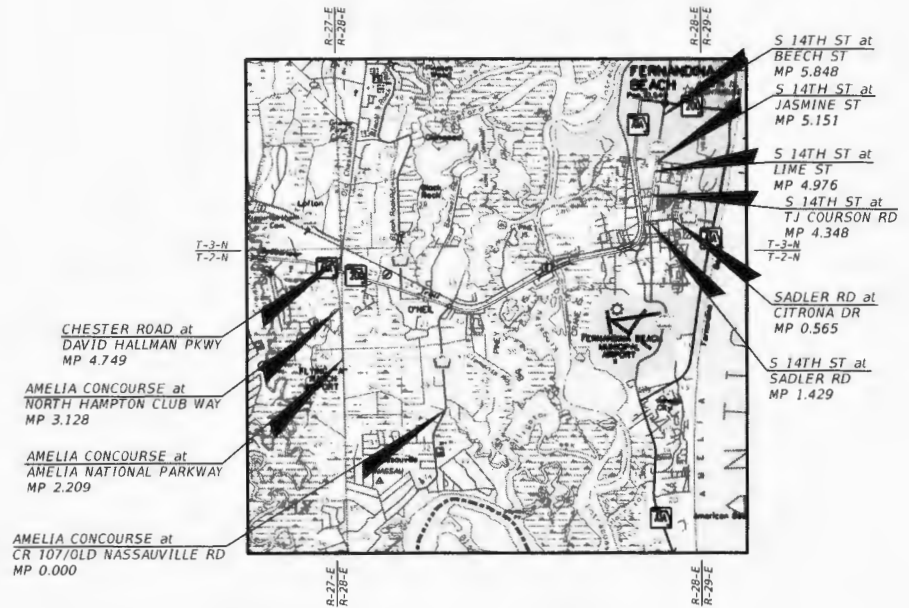

REVISIONS			
DATE	DESCRIPTION	DATE	DESCRIPTION

Ernest Lee Herbert IV, P.E.
P.E. License Number 79413
Comprehensive Engineering Services, Inc.
201 S Orange Ave, Suite 1300
Orlando, FL 32801-3442

STATE OF FLORIDA DEPARTMENT OF TRANSPORTATION		
ROAD NO.	COUNTY	FINANCIAL PROJECT ID
N/A	NASSAU	441217-1-52-01

KEY MAP SHEET

SHEET NO.
S-2

THIS SHEET IS THE ELECTRONIC FILE DIGITALLY SIGNED AND SEALED UNDER RULE 61G15-23.004, F.A.C.

Contract No. CM3150

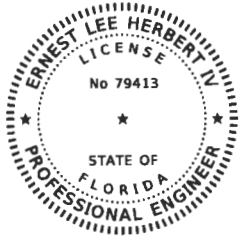

THIS ITEM HAS BEEN DIGITALLY
SIGNED AND SEALED BY

ON THE DATE ADJACENT TO THE SEAL

PRINTED COPIES OF THIS DOCUMENT ARE
NOT CONSIDERED SIGNED AND SEALED
AND THE SIGNATURE MUST BE VERIFIED
ON ANY ELECTRONIC COPIES.

COMPREHENSIVE ENGINEERING SERVICES, INC.
201 S. ORANGE AVENUE, SUITE 1300
ORLANDO, FLORIDA 32801
ERNEST LEE HERBERT IV, P.E. NO. 79413

THE ABOVE NAMED PROFESSIONAL ENGINEER SHALL BE RESPONSIBLE FOR THE
FOLLOWING SHEETS IN ACCORDANCE WITH RULE 61G15-23.004, F.A.C.

SHEET NO.	SHEET DESCRIPTION
S-1	KEY SHEET
S-2	KEY MAP SHEET
S-3	SIGNATURE SHEET
S-4 - S-7	TABULATION OF QUANTITIES
S-8	GENERAL NOTES
S-9 - S-44	SIGNING AND PAVEMENT MARKING PLAN
S-45	TEMPORARY TRAFFIC CONTROL PLAN
SO-1 TO SO-2	SUMMARY OF QUANTITIES

REVISIONS				Ernest Lee Herbert IV, P.E. P.E. License Number 79413 Comprehensive Engineering Services, Inc. 201 S Orange Ave, Suite 1300 Orlando, FL 32801-3442	STATE OF FLORIDA DEPARTMENT OF TRANSPORTATION			<i>SIGNATURE SHEET</i>	SHEET NO.
DATE	DESCRIPTION	DATE	DESCRIPTION		ROAD NO.	COUNTY	FINANCIAL PROJECT ID		S-3
					N/A	NASSAU	441217-1-52-01		

LHerbert

11/18/2021

4:22:07 PM

T:\Projects\1500807\44121715201\sigang\sgnsp01.dgn

Contract No. CM3150
Bid No. NC21-014

TABULATION OF QUANTITIES

PAY ITEM NO.	DESCRIPTION	UNIT	SHEET NUMBERS														TOTAL THIS SHEET		GRAND TOTAL		REF. SHEET			
			S-9		S-10		S-11		S-12		S-13		S-14		S-15		S-16		S-17					
			PLAN	FINAL	PLAN	FINAL	PLAN	FINAL	PLAN	FINAL	PLAN	FINAL	PLAN	FINAL	PLAN	FINAL	PLAN	FINAL	PLAN	FINAL				
700 1 11	SGL POST SIGN, F&I GRD MNT, UP-12 SF	AS	2		2		2		2		2		2		2		2		10		26			
700 1 12	SGL POST SIGN, F&I GRD MNT, 12-20 SF	AS																	1		1			
700 1 13	SGL POST SIGN, F&I GRD MNT, 21-30 SF	AS																						
700 1 60	SINGLE POST SIGN, REMOVE	AS			1		2		1		1		1		1		1		3		12			
700 3 501	SIGN PANEL, RELOCATE, UP TO 12 SF	EA	4		4		2		3		3		3		3		3				25			
700 3 601	SIGN PANEL, REMOVE, UP TO 12 SF	EA																	1		1			
700 13 15	RETROREFLECTIVE SIGN STRIP	EA	5		5		5		5		5		5		5		5		6		46			
701 18 101	PROFILED THERMOPLASTIC, STD ASPHALT SURFACES, WHITE, SOLID, 6"	GM																						
705 10 1	OBJECT MARKER, TYPE 1	EA	3		3		3		3		3		3		3		3				24			
706 1 1	RAISED PAVEMENT MARKER, TYPE B WITHOUT FINAL SURFACE MARKINGS	EA																						
710 90	PAINTED PAVEMENT MARKINGS-FINAL SURFACE	LS																						
*	RETRO-REFLECTIVE PAVEMENT MARKERS	EA	66		12		6		66		54		48		12						264			
*	PAINTED PAVEMENT MARKINGS, STANDARD, WHITE, SOLID, 6"	GM																						
*	PAINTED PAVEMENT MARKINGS, STD, WHITE, SOLID FOR STOP LINE, 24"	LF			18		19								19						56			
*	PAINTED PAVEMENT MARKINGS, STANDARD, WHITE, MESSAGE OR SYMBOL	EA			1		1								1						3			
*	PAINTED PAVEMENT MARKINGS, STANDARD, YELLOW, SOLID, 6"	GM	0.246		0.076		0.040		0.237		0.193		0.214		0.076						1.082			
*	PAINTED PAVEMENT MARKINGS, STANDARD, YELLOW, SKIP, 6"	GM	0.246						0.237				0.123								0.606			
711 11 123	THERMOPLASTIC, STANDARD, WHITE, SOLID, 12"	LF																						
711 11 125	THERMOPLASTIC, STANDARD, WHITE, SOLID, 24"	LF																		15		15		
711 11 160	THERMOPLASTIC, STANDARD, WHITE, MESSAGE	EA																		2		2		
711 14 125	THERMOPLASTIC, PREFORMED, WHITE, SOLID 24" FOR CROSSWALK	LF																						
711 16 201	THERMO, STD-OTHER SURF, YELLOW, SOLID, 6"	GM																						
711 16 231	THERMO, STD-OTHER SURF, YELLOW, SKIP, 6"	GM																						
711 17 1	THERMOPLASTIC, REMOVE- SURFACE TO REMAIN	SF	168		13				162		160		117								620			

* THESE QUANTITIES ARE PAID FOR UNDER PAINTED PAVEMENT MARKINGS (FINAL SURFACE), LUMP SUM-ITEM 710-90 THE QUANTITIES ARE FOR ONE APPLICATION; SEE SPECIFICATION 710 FOR THE NUMBER OF APPLICATIONS REQUIRED.

REVISIONS				Ernest Lee Herbert IV, P.E. P.E. License Number 79413 Comprehensive Engineering Services, Inc. 201 S Orange Ave, Suite 1300 Orlando, FL 32801-3442	STATE OF FLORIDA DEPARTMENT OF TRANSPORTATION			TABULATION OF QUANTITIES	SHEET NO. 5-4
DATE	DESCRIPTION	DATE	DESCRIPTION		ROAD NO	COUNTY	FINANCIAL PROJECT ID		
					N/A	NA5SAU	441217-1-52-01		

E:Herbert

11/18/2021

4:22:08 PM

T:\Projects\1500807\441217\15201\signing\tab01.dgn

Contract No. CM3150
 THIS SHEET IS THE ELECTRONIC FILE DIGITALLY SIGNED AND SEALED UNDER RULE 61G15-23.004, F.A.C.
 RECORDED BY: NCE 11/18/21
 FILE NO: 2021-014

TABULATION OF QUANTITIES

PAY ITEM NO.	DESCRIPTION	UNIT	SHEET NUMBERS														TOTAL THIS SHEET		GRAND TOTAL		REF. SHEET				
			S-18		S-19		S-20		S-21		S-22		S-23		S-24		S-25		S-26			PLAN	FINAL	PLAN	FINAL
			PLAN	FINAL	PLAN	FINAL	PLAN	FINAL	PLAN	FINAL	PLAN	FINAL	PLAN	FINAL	PLAN	FINAL	PLAN	FINAL							
700 1 11	SGL POST SIGN, F&I GRD MNT, UP 12 SF	AS	2		2		3		14		2		2		2		2		2		31				
700 1 12	SGL POST SIGN, F&I GRD MNT, 12-20 SF	AS																							
700 1 13	SGL POST SIGN, F&I GRD MNT, 21-30 SF	AS																							
700 1 60	SINGLE POST SIGN, REMOVE	AS	1		1			2		1		1		5		1		1		13					
700 3 501	SIGN PANEL, RELOCATE, UP TO 12 SF	EA	4		4					4		3		4		3		3		25					
700 3 601	SIGN PANEL, REMOVE, UP TO 12 SF	EA																							
700 13 15	RETROREFLECTIVE SIGN STRIP	EA	5		5		6			5		5		5		5		5		41					
701 18 101	PROFILED THERMOPLASTIC, STD-ASPHALT SURFACES, WHITE, SOLID, 6"	GM																							
705 10 1	OBJECT MARKER, TYPE 1	EA	3		3					3		3		3		3		3		21					
706 1 1	RAISED PAVEMENT MARKER, TYPE B WITHOUT FINAL SURFACE MARKINGS	EA					66			16		52		10		17		27		188					
710 90	PAINTED PAVEMENT MARKINGS-FINAL SURFACE	LS																							
*	RETRO-REFLECTIVE PAVEMENT MARKERS	EA																							
*	PAINTED PAVEMENT MARKINGS, STANDARD, WHITE, SOLID, 6"	GM																							
*	PAINTED PAVEMENT MARKINGS, STD, WHITE, SOLID FOR STOP LINE, 24"	LF																							
*	PAINTED PAVEMENT MARKINGS, STANDARD, WHITE, MESSAGE OR SYMBOL	EA																							
*	PAINTED PAVEMENT MARKINGS, STANDARD, YELLOW, SOLID, 6"	GM																							
*	PAINTED PAVEMENT MARKINGS, STANDARD, YELLOW, SKIP, 6"	GM																							
711 11 123	THERMOPLASTIC, STANDARD, WHITE, SOLID, 12"	LF																							
711 11 123	THERMOPLASTIC, STANDARD, WHITE, SOLID, 24"	LF			20		14							16						50					
711 11 160	THERMOPLASTIC, STANDARD, WHITE, MESSAGE	EA																							
711 14 125	THERMOPLASTIC, PREFORMED, WHITE, SOLID 24" FOR CROSSWALK	LF																							
711 16 201	THERMO, STD-OTHER SURF, YELLOW, SOLID, 6"	GM				0.246				0.118		0.284		0.076		0.123		0.275		1.122					
711 16 231	THERMO, STD-OTHER SURF, YELLOW, SKIP, 6"	GM				0.246				0.095		0.095								0.436					
711 17 1	THERMOPLASTIC, REMOVE SURFACE TO REMAIN	SF				173				188		328		216		82		82		1069					

* THESE QUANTITIES ARE PAID FOR UNDER PAINTED PAVEMENT MARKINGS (FINAL SURFACE), LUMP SUM-ITEM 710-90. THE QUANTITIES ARE FOR ONE APPLICATION; SEE SPECIFICATION 710 FOR THE NUMBER OF APPLICATIONS REQUIRED.

REVISIONS		DESCRIPTION		Ernest Lee Herbert IV, P.E. P.E. License Number 79413 Comprehensive Engineering Services, Inc. 201 S Orange Ave, Suite 1300 Orlando, FL 32801-3442	STATE OF FLORIDA DEPARTMENT OF TRANSPORTATION			TABULATION OF QUANTITIES	SHEET NO. S-5
DATE	DESCRIPTION	DATE	DESCRIPTION		ROAD NO.	COUNTY	FINANCIAL PROJECT ID		
					N/A	NA55AU	441217-1-52-01		

EHerbert

1/18/2021

4:22:08 PM

T:\Projects\1500807\441217\15201\signing\tabsp01.dgn

THIS SHEET IS THE ELECTRONIC FILE DIGITALLY SIGNED AND SEALED UNDER RULE 61G15-23.004, F.A.C.
 FILE NO. 2021-014
 REC'D BY: [Signature]

Contract No. CM3150

TABULATION OF QUANTITIES

PAY ITEM NO.	DESCRIPTION	UNIT	SHEET NUMBERS																TOTAL THIS SHEET		GRAND TOTAL		REF. SHEET		
			S-27		S-28		S-29		S-30		S-31		S-32		S-33		S-34		S-35		PLAN	FINAL		PLAN	FINAL
			PLAN	FINAL	PLAN	FINAL	PLAN	FINAL	PLAN	FINAL	PLAN	FINAL	PLAN	FINAL	PLAN	FINAL	PLAN	FINAL							
700 1 11	SGL POST SIGN, F&I GRD MNT, UP 12 SF	AS	2		4		4		2		2									14					
700 1 12	SGL POST SIGN, F&I GRD MNT, 12-20 SF	AS																		31					
700 1 13	SGL POST SIGN, F&I GRD MNT, 21-30 SF	AS																							
700 1 60	SINGLE POST SIGN, REMOVE	AS	1					1		1										34					
700 3 501	SIGN PANEL, RELOCATE, UP TO 12 SF	EA	3					3												6					
700 3 601	SIGN PANEL, REMOVE, UP TO 12 SF	EA																							
700 13 15	RETROREFLECTIVE SIGN STRIP	EA	5		6		6		5		4		5		6		13		8	58					
701 18 101	PROFILED THERMOPLASTIC, STD-ASPHALT SURFACES, WHITE, SOLID, 6"	GM																		16.688					
705 10 1	OBJECT MARKER, TYPE 1	EA	3					3												6					
706 1 1	RAISED PAVEMENT MARKER, TYPE B WITHOUT FINAL SURFACE MARKINGS	EA																							
710 90	PAINTED PAVEMENT MARKINGS-FINAL SURFACE	LS																							
*	RETRO-REFLECTIVE PAVEMENT MARKERS	EA																							
*	PAINTED PAVEMENT MARKINGS, STANDARD, WHITE, SOLID, 6"	GM									10.000		4.958							14.958					
*	PAINTED PAVEMENT MARKINGS, STD, WHITE, SOLID FOR STOP LINE, 24"	LF																							
*	PAINTED PAVEMENT MARKINGS, STANDARD, WHITE, MESSAGE OR SYMBOL	EA																							
*	PAINTED PAVEMENT MARKINGS, STANDARD, YELLOW, SOLID, 6"	GM																							
*	PAINTED PAVEMENT MARKINGS, STANDARD, YELLOW, SKIP, 6"	GM																							
711 11 123	THERMOPLASTIC, STANDARD, WHITE, SOLID, 12"	LF																							
711 11 125	THERMOPLASTIC, STANDARD, WHITE, SOLID, 24"	LF																							
711 11 160	THERMOPLASTIC, STANDARD, WHITE, MESSAGE	EA																							
711 14 125	THERMOPLASTIC, PREFORMED, WHITE, SOLID 24" FOR CROSSWALK	LF																							
711 16 201	THERMO, STD-OTHER SURF, YELLOW, SOLID, 6"	GM																							
711 16 231	THERMO, STD-OTHER SURF, YELLOW, SKIP, 6"	GM																							
711 17 1	THERMOPLASTIC, REMOVE- SURFACE TO REMAIN	SF					173								13311		26400		4346	44230					

* THESE QUANTITIES ARE PAID FOR UNDER PAINTED PAVEMENT MARKINGS (FINAL SURFACE), LUMP SUM-ITEM 710-90. THE QUANTITIES ARE FOR ONE APPLICATION; SEE SPECIFICATION 710 FOR THE NUMBER OF APPLICATIONS REQUIRED.

REVISIONS DATE DESCRIPTION DATE DESCRIPTION				Ernest Lee Herbert IV, P.E. P.E. License Number 79413 Comprehensive Engineering Services, Inc. 201 S Orange Ave, Suite 1300 Orlando, FL 32801-3442	STATE OF FLORIDA DEPARTMENT OF TRANSPORTATION			TABULATION OF QUANTITIES	SHEET NO. 5-6
ROAD NO	COUNTY	FINANCIAL PROJECT ID	N/A		NASSAU	441217-1-52-01			

EHerbert

11/18/2021

4:22:08 PM

T:\Projects\1560807\441217\5201\signing\tabq01.dgn

THIS SHEET IS THE ELECTRONIC FILE DIGITALLY SIGNED AND SEALED UNDER RULE 61G15-23.004, F.A.C.

Contract No. CM3150

TABULATION OF QUANTITIES

PAY ITEM NO.	DESCRIPTION	UNIT	SHEET NUMBERS																TOTAL THIS SHEET		GRAND TOTAL		REF. SHEET		
			S-36		S-37		S-38		S-39		S-40		S-41		S-42		S-43		S-44		PLAN	FINAL		PLAN	FINAL
			PLAN	FINAL	PLAN	FINAL	PLAN	FINAL	PLAN	FINAL	PLAN	FINAL	PLAN	FINAL	PLAN	FINAL	PLAN	FINAL							
700 1 11	SGL POST SIGN, F&I GRD MNT, UP TO 12 SF	AS																		71					
700 1 12	SGL POST SIGN, F&I GRD MNT, 12-20 SF	AS	5		5		7													17			49		
700 1 13	SGL POST SIGN, F&I GRD MNT, 21-30 SF	AS	1																	1			7		
700 1 60	SINGLE POST SIGN, REMOVE	AS	6		5		7													18			77		
700 3 501	SIGN PANEL, RELOCATE, UP TO 12 SF	EA																					56		
700 3 601	SIGN PANEL, REMOVE, UP TO 12 SF	EA																					7		
700 13 15	RETROREFLECTIVE SIGN STRIP	EA	9		5		7													21			166		
701 18 101	PROFILED THERMOPLASTIC, STD-ASPHALT SURFACES, WHITE, SOLID, 6"	GM																					16,688		
705 10 1	OBJECT MARKER, TYPE 1	EA																					51		
706 1 1	RAISED PAVEMENT MARKER, TYPE B WITHOUT FINAL SURFACE MARKINGS	EA																					188		
710 90	PAINTED PAVEMENT MARKINGS-FINAL SURFACE	LS																					7		
*	RETRO-REFLECTIVE PAVEMENT MARKERS	EA																					264		
*	PAINTED PAVEMENT MARKINGS, STANDARD, WHITE, SOLID, 6"	GM																					14,958		
*	PAINTED PAVEMENT MARKINGS, STD, WHITE, SOLID FOR STOP LINE, 24"	LF																					56		
*	PAINTED PAVEMENT MARKINGS, STANDARD, WHITE, MESSAGE OR SYMBOL	EA																					3		
*	PAINTED PAVEMENT MARKINGS, STANDARD, YELLOW, SOLID, 6"	GM																					1,082		
*	PAINTED PAVEMENT MARKINGS, STANDARD, YELLOW, SKIP, 6"	GM																					0,606		
711 11 123	THERMOPLASTIC, STANDARD, WHITE, SOLID, 12"	LF							869			891		1077		474		748	4059			4059			
711 11 125	THERMOPLASTIC, STANDARD, WHITE, SOLID, 24"	LF																				65			
711 11 160	THERMOPLASTIC, STANDARD, WHITE, MESSAGE	EA																				2			
711 14 125	THERMOPLASTIC, PREFORMED, WHITE, SOLID 24" FOR CROSSWALK	LF							535			686		805		335		569	2930			2930			
711 16 201	THERMO, STD-OTHER SURF, YELLOW, SOLID, 6"	GM																				1,122			
711 16 231	THERMO, STD-OTHER SURF, YELLOW, SKIP, 6"	GM																				0,436			
711 17 1	THERMOPLASTIC, REMOVE SURFACE TO REMAIN	SF							869			891		1077		474		1088	4399			50318			

* THESE QUANTITIES ARE PAID FOR UNDER PAINTED PAVEMENT MARKINGS (FINAL SURFACE), LUMP SUM-ITEM 710-90 THE QUANTITIES ARE FOR ONE APPLICATION. SEE SPECIFICATION 710 FOR THE NUMBER OF APPLICATIONS REQUIRED.

REVISIONS DATE DESCRIPTION DATE DESCRIPTION		Ernest Lee Herbert IV, P.E. P.E. License Number 79413 Comprehensive Engineering Services, Inc. 201 S Orange Ave, Suite 1300 Orlando, FL 32801-3442	STATE OF FLORIDA DEPARTMENT OF TRANSPORTATION			TABULATION OF QUANTITIES	SHEET NO. S-7
ROAD NO.	COUNTY		FINANCIAL PROJECT ID				
N/A	NASSAU	441217-1-52-01					

Elherbert

11/18/2021

4:22:09 PM

T:\Projects\150080\441217\15201\signing\tabs\p01.dgn

THIS SHEET IS THE ELECTRONIC FILE DIGITALLY SIGNED AND SEALED UNDER RULE 61G15-23.004, F.A.C.

Contract No. CM3150

GENERAL NOTES

- 1 MAINTAIN EXISTING STREET NAME SIGNS FOR 911 PURPOSES. COST FOR ALL RELOCATIONS DURING MAINTENANCE OF TRAFFIC TO BE INCLUDED UNDER RELATED PAY ITEM(S).
- 2 ALL EXISTING SIGNING TO REMAIN UNLESS OTHERWISE NOTED.
- 3 EXISTING SIGNS TO BE RELOCATED TO PROPOSED SIGN ASSEMBLIES SHALL BE INSTALLED TO MATCH THE EXISTING CONFIGURATION.
- 4 INSTALL OBJECT MARKERS WITH A MINIMUM MOUNTING HEIGHT OF 4' MEASURED FROM THE BOTTOM OF THE OBJECT MARKER TO THE ELEVATION OF THE NEAR EDGE OF THE TRAVELLED WAY.
- 5 SURVEY WAS NOT COMPLETED FOR THIS PROJECT AND TOPOGRAPHICAL FEATURES SHOWN IN THE PLANS ARE APPROXIMATED BASED ON AERIALS.
- 6 THE R/W LINES SHOWN IN THE PLANS ARE NOT SURVEYED. THE R/W LINES ARE BASED UPON SCALING FROM THE NASSAU COUNTY TAX MAPS AND COMPARISON WITH EXISTING AERIAL PHOTOGRAPHS OF TOPOGRAPHICAL FEATURES. AS SUCH, THE LOCATION OF ALL R/W LINES SHOWN IN THE PLANS SHOULD BE CONSIDERED APPROXIMATE.
- 7 NO WORKERS OR EQUIPMENT SHALL ENCRDACH ON THE NORFOLK SOUTHERN RAILROAD R/W.

RPM ABBREVIATIONS

Y/Y = BI-DIRECTIONAL YELLOW-YELLOW

REVISIONS				Ernest Lee Herbert IV, P.E. P.E. License Number 79413 Comprehensive Engineering Services, Inc. 201 S Orange Ave., Suite 1300 Orlando, FL 32801-3442	STATE OF FLORIDA DEPARTMENT OF TRANSPORTATION			GENERAL NOTES	SHEET NO.
DATE	DESCRIPTION	DATE	DESCRIPTION		ROAD NO.	COUNTY	FINANCIAL PROJECT ID		
					N/A	NASSAU	441217-1-52-01		5-8

EHerbert

11/18/2021

4:22:09 PM

I:\Projects\1500807\441217\15201\signing\qmt.sp01.dgn

THIS SHEET IS THE ELECTRONIC FILE DIGITALLY SIGNED AND SEALED UNDER RULE 61G15-23.004, F.A.C.

PROJECT NO. NC210114

Contract No. CM3150

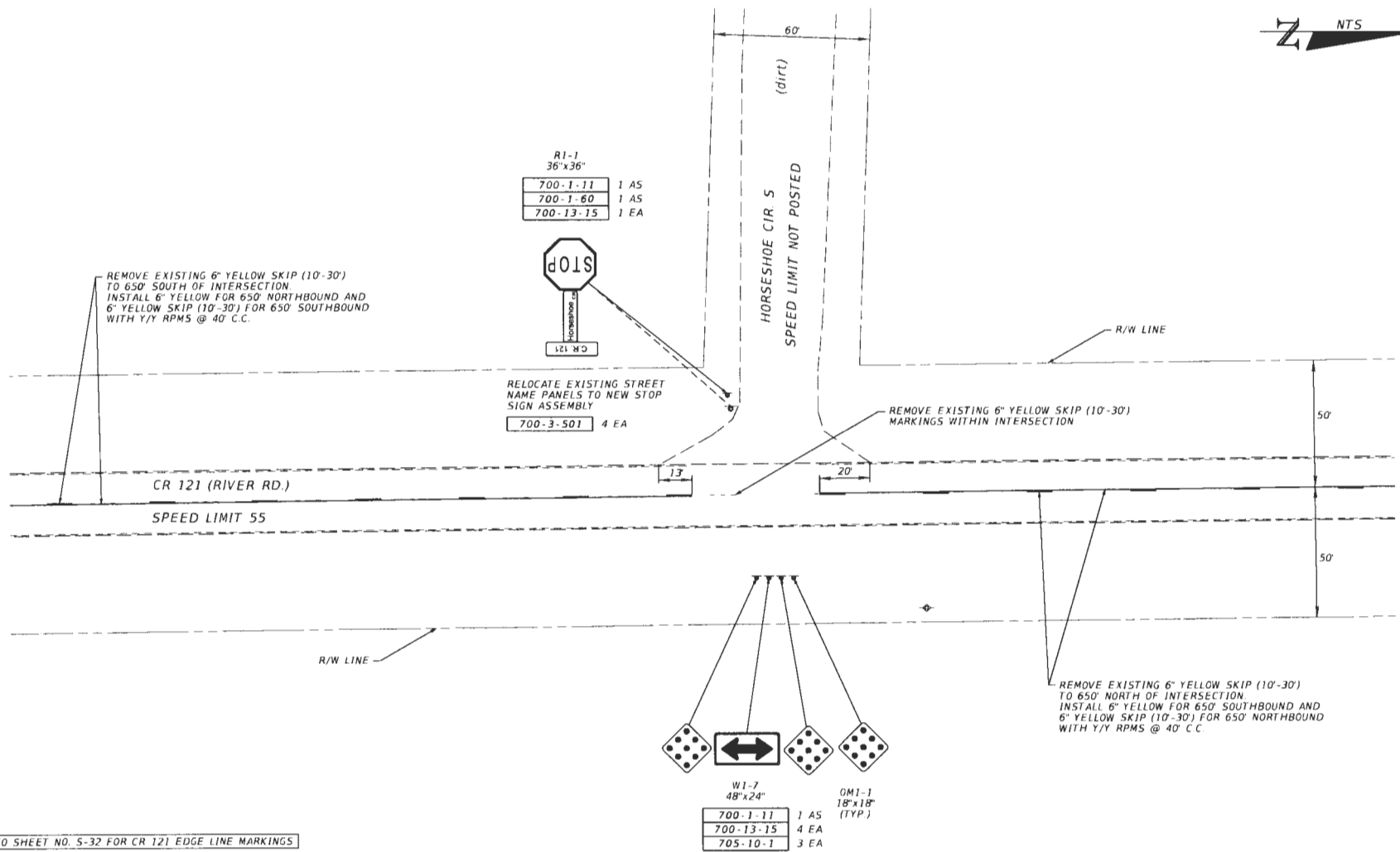

REFER TO SHEET NO. S-32 FOR CR 121 EDGE LINE MARKINGS

CR 121/RIVER RD. AT HORSESHOE CIR. S

REVISIONS				Ernest Lee Herbert IV, P.E. P.E. License Number 79413 Comprehensive Engineering Services, Inc. 201 S Orange Ave, Suite 1300 Orlando, FL 32801-3442	STATE OF FLORIDA DEPARTMENT OF TRANSPORTATION			SIGNING AND PAVEMENT MARKING PLAN	SHEET NO. S-9
DATE	DESCRIPTION	DATE	DESCRIPTION		ROAD NO.	COUNTY	FINANCIAL PROJECT ID		
					CR 121	NASSAU	441217-I-52-01		

Contract No. CM3150
 Bid No. NC21-014
 THIS SHEET IS THE ELECTRONIC FILE DIGITALLY SIGNED AND SEALED UNDER RULE 61B15-23.004, F.A.C.

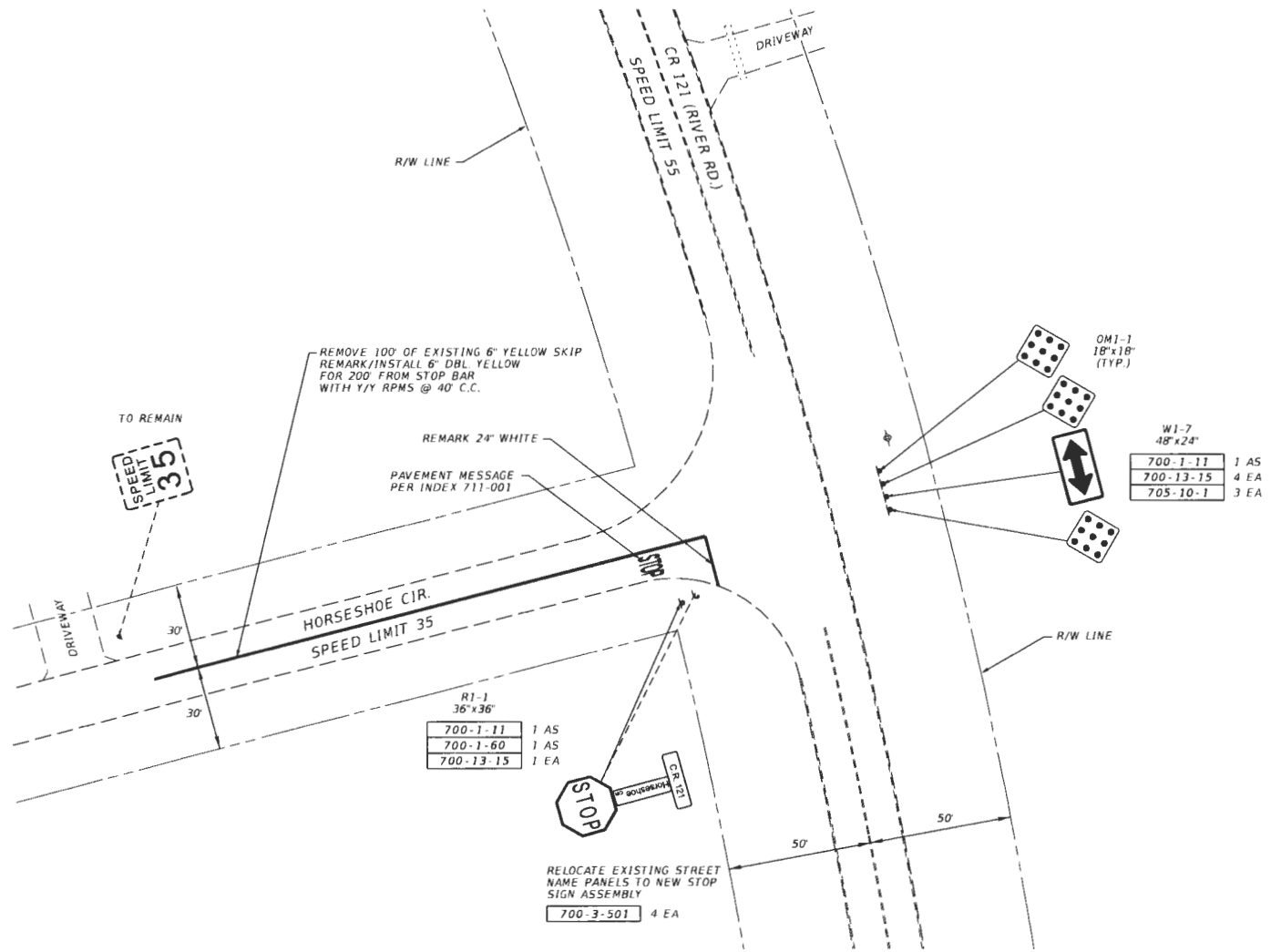

REFER TO SHEET NO. S-32 FOR CR 121 EDGE LINE MARKINGS.

CR 121/RIVER RD. AT HORSESHOE CIR.

REVISIONS		DESCRIPTION		Ernest Lee Herbert IV, P.E. P.E. License Number 79413 Comprehensive Engineering Services, Inc. 201 S Orange Ave, Suite 1300 Orlando, FL 32801-3442	STATE OF FLORIDA DEPARTMENT OF TRANSPORTATION			SHEET NO. S-10
DATE	DESCRIPTION	DATE	DESCRIPTION		ROAD NO.	COUNTY	FINANCIAL PROJECT ID	
					CR 121	NASSAU	441217-1-52-01	

THIS SHEET IS THE ELECTRONIC FILE DIGITALLY SIGNED AND SEALED UNDER RULE 61G15-23.004, F.A.C.
 PROJECT RECORD NO. 2019-0114
 Contract No. CM3150

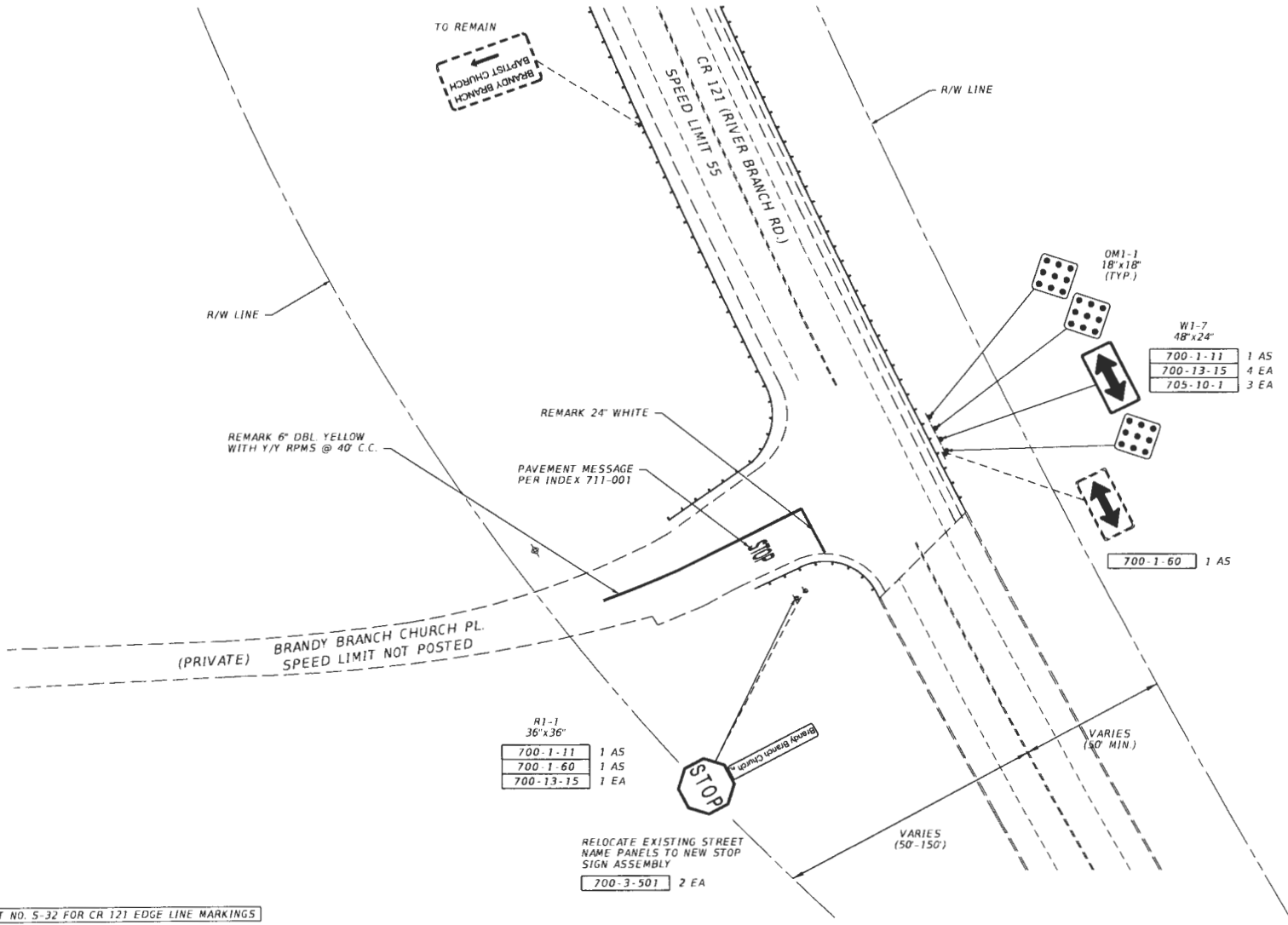

REFER TO SHEET NO. S-32 FOR CR 121 EDGE LINE MARKINGS

CR 121/RIVER RD. AT BRANDY BRANCH CHURCH PL.

REVISIONS			
DATE	DESCRIPTION	DATE	DESCRIPTION

Ernest Lee Herbert IV, P.E.
 P.E. License Number 79413
 Comprehensive Engineering Services, Inc.
 201 S Orange Ave, Suite 1300
 Orlando, FL 32801-3442

STATE OF FLORIDA DEPARTMENT OF TRANSPORTATION		
ROAD NO	COUNTY	FINANCIAL PROJECT ID
CR 121	NASSAU	441217-1-52-01

SIGNING AND PAVEMENT MARKING PLAN	
SHEET NO.	S-11

THIS SHEET IS THE ELECTRONIC FILE DIGITALLY SIGNED AND SEALED UNDER RULE 61015-23 004, F.A.C.

Contract No. CM3150



REMOVE EXISTING 6" YELLOW SKIP (10'-30') TO 650' SOUTH OF INTERSECTION.
 INSTALL 6" YELLOW FOR 650' SOUTHBOUND AND 6" YELLOW SKIP (10'-30') FOR 650' NORTHBOUND WITH Y/Y RPMS @ 40' C.C.

R1-1	36"x36"	
700-1-11		1 AS
700-1-60		1 AS
700-13-15		1 EA

RELOCATE EXISTING STREET NAME PANELS TO NEW STOP SIGN ASSEMBLY
 700-3-501 3 EA



BOYD RD.
 (dirt)
 SPEED LIMIT NOT POSTED

REMOVE EXISTING 6" YELLOW SKIP (10'-30') MARKINGS WITHIN INTERSECTION

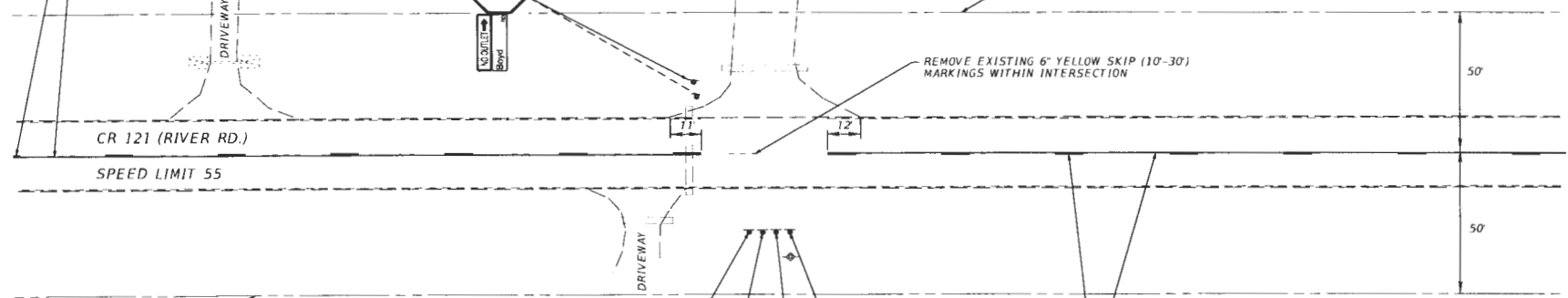

REMOVE EXISTING 6" YELLOW SKIP (10'-30') TO EXISTING NO-PASSING ZONE NORTHBOUND 600' NORTH OF INTERSECTION.
 INSTALL 6" YELLOW FOR 600' SOUTHBOUND AND 6" YELLOW SKIP (10'-30') FOR 600' NORTHBOUND WITH Y/Y RPMS @ 40' C.C.

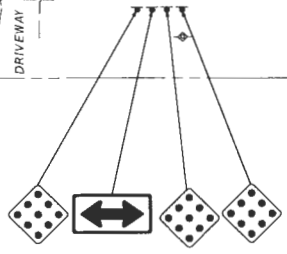

W1-7	48"x24"	
700-1-11		1 AS
700-13-15		4 EA
705-10-1		3 EA

OM1-1
 18"x18"
 (TYP.)

REFER TO SHEET NO. S-32 FOR CR 121 EDGE LINE MARKINGS.

CR 121/RIVER RD. AT BOYD RD.

REVISIONS			
DATE	DESCRIPTION	DATE	DESCRIPTION

Ernest Lee Herbert IV, P.E.
 P.E. License Number 79413
 Comprehensive Engineering Services, Inc.
 201 S Orange Ave, Suite 1300
 Orlando, FL 32801-3442

STATE OF FLORIDA DEPARTMENT OF TRANSPORTATION		
ROAD NO.	COUNTY	FINANCIAL PROJECT ID
CR 121	NASSAU	441217-1-52-01

**SIGNING AND PAVEMENT
 MARKING PLAN**

SHEET NO.
S-12

CONTRACT NO. CM3150
 SHEET NO. S-12 OF 14
 THIS SHEET IS THE ELECTRONIC FILE DIGITALLY SIGNED AND SEALED UNDER RULE 61G15-23.004, F.A.C.

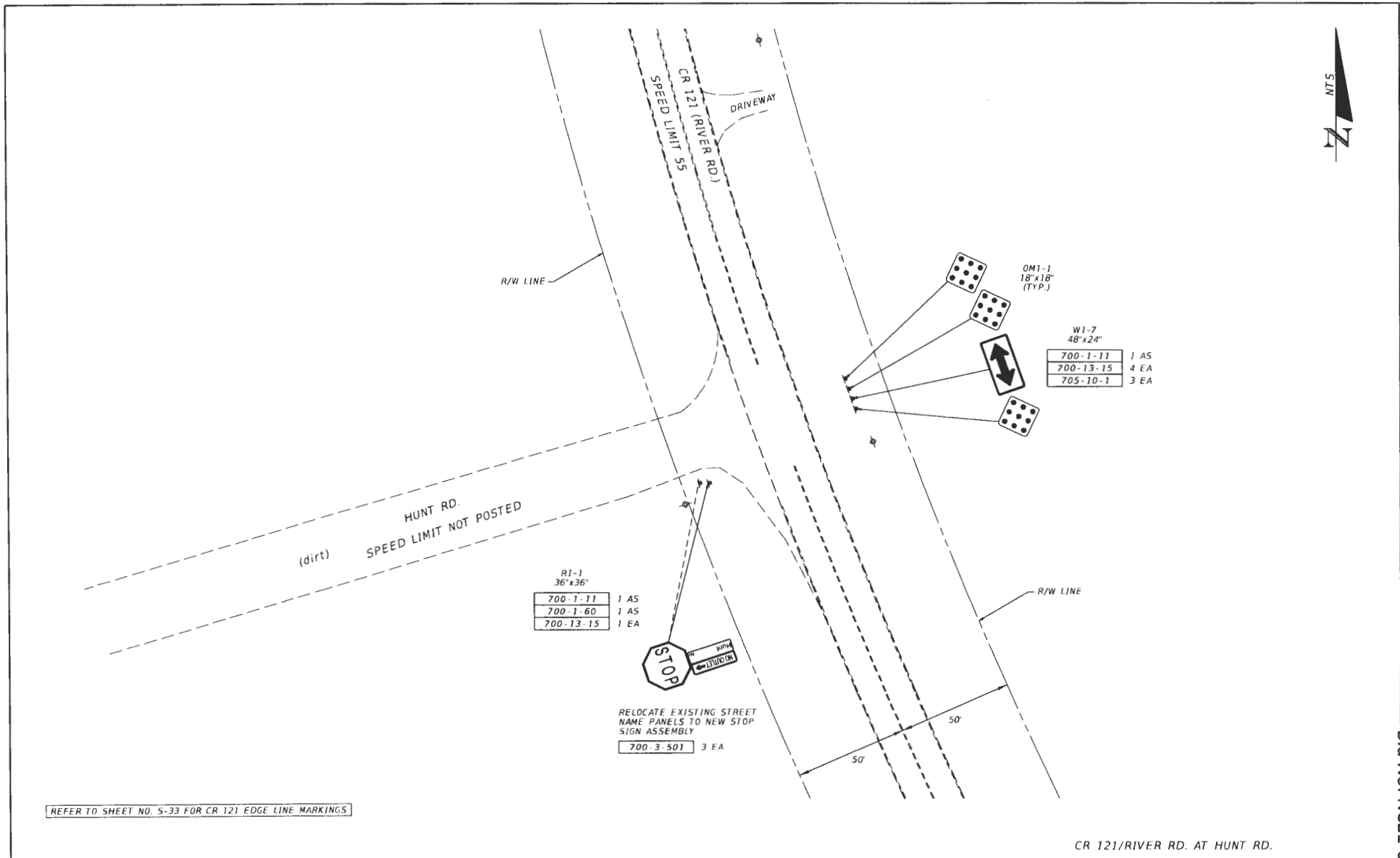

CR 121/RIVER RD. AT HUNT RD.

REVISIONS		DESCRIPTION	
DATE	DESCRIPTION	DATE	DESCRIPTION

Ernest Lee Herbert IV, P.E. P.E. License Number 79413 Comprehensive Engineering Services, Inc. 201 S Orange Ave, Suite 1300 Orlando, FL 32801-3442			STATE OF FLORIDA DEPARTMENT OF TRANSPORTATION		
ROAD NO.	COUNTY	FINANCIAL PROJECT ID	SIGNING AND PAVEMENT MARKING PLAN		
CR 121	NASSAU	441217-1-52-01	SHEET NO. S-13		

CONTRACT NO. CM3150
 SHEET IS THE ELECTRONIC FILE DIGITALLY SIGNED AND SEALED UNDER RULE 61G15-23.004, F.A.C.
 PROJECT NO. 2021-014



R1-1	36"x36"	
700-1-11		1 AS
700-1-60		1 AS
700-13-15		1 EA

RELOCATE EXISTING STREET
NAME PANELS TO NEW STOP
SIGN ASSEMBLY

700-3-501	3 EA
-----------	------

REFER TO SHEET NO. S-33
FOR CURVE SIGNING
MP 6.345



60'

NICHOLS LN.
(dirt)
SPEED LIMIT NOT POSTED

R/W LINE

REMOVE EXISTING CENTERLINE
MARKINGS WITHIN INTERSECTION

50'

CR 121

SPEED LIMIT 55

DRIVEWAY

DRIVEWAY

R/W LINE

NORTHBOUND:
REMOVE EXISTING 6" YELLOW SKIP (10'-30')
TO EXISTING NO-PASSING ZONE
750' SOUTH OF INTERSECTION
INSTALL 6" YELLOW FOR 750'
WITH Y/Y RPMS @ 40' C.C.

NORTHBOUND:
REMOVE EXISTING 6" YELLOW SKIP (10'-30')
TO 290' NORTH OF INTERSECTION
INSTALL 6" YELLOW FOR 290'
WITH Y/Y RPMS @ 40' C.C.

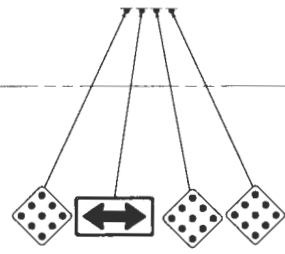

W1-7	48"x24"	
700-1-11		1 AS
700-13-15		4 EA
705-10-1		3 EA

DM1-1	18"x18"	(TYP.)
-------	---------	--------

REFER TO SHEET NO. S-33 FOR CR 121 EDGE LINE MARKINGS

CR 121 AT NICHOLS LN.

REVISIONS				Ernest Lee Herbert IV, P.E. P.E. License Number 79413 Comprehensive Engineering Services, Inc. 201 S Orange Ave, Suite 1300 Orlando, FL 32801-3442	STATE OF FLORIDA DEPARTMENT OF TRANSPORTATION			SIGNING AND PAVEMENT MARKING PLAN	SHEET NO. S-14
DATE	DESCRIPTION	DATE	DESCRIPTION		ROAD NO.	COUNTY	FINANCIAL PROJECT ID		
					CR 121	NASSAU	441217-1-52-01		

Contract No. CM3150
 SHEET 15 THE ELECTRONIC FILE DIGITALLY SIGNED AND SEALED UNDER RULE 61G15-23.004, F.A.C.
 1500807-44121715201



R1-1	36"x36"	
700-1-11	1 AS	
700-1-60	1 AS	
700-13-15	1 EA	

RELOCATE EXISTING STREET NAME PANELS TO NEW STOP SIGN ASSEMBLY
 700-3-501 3 EA

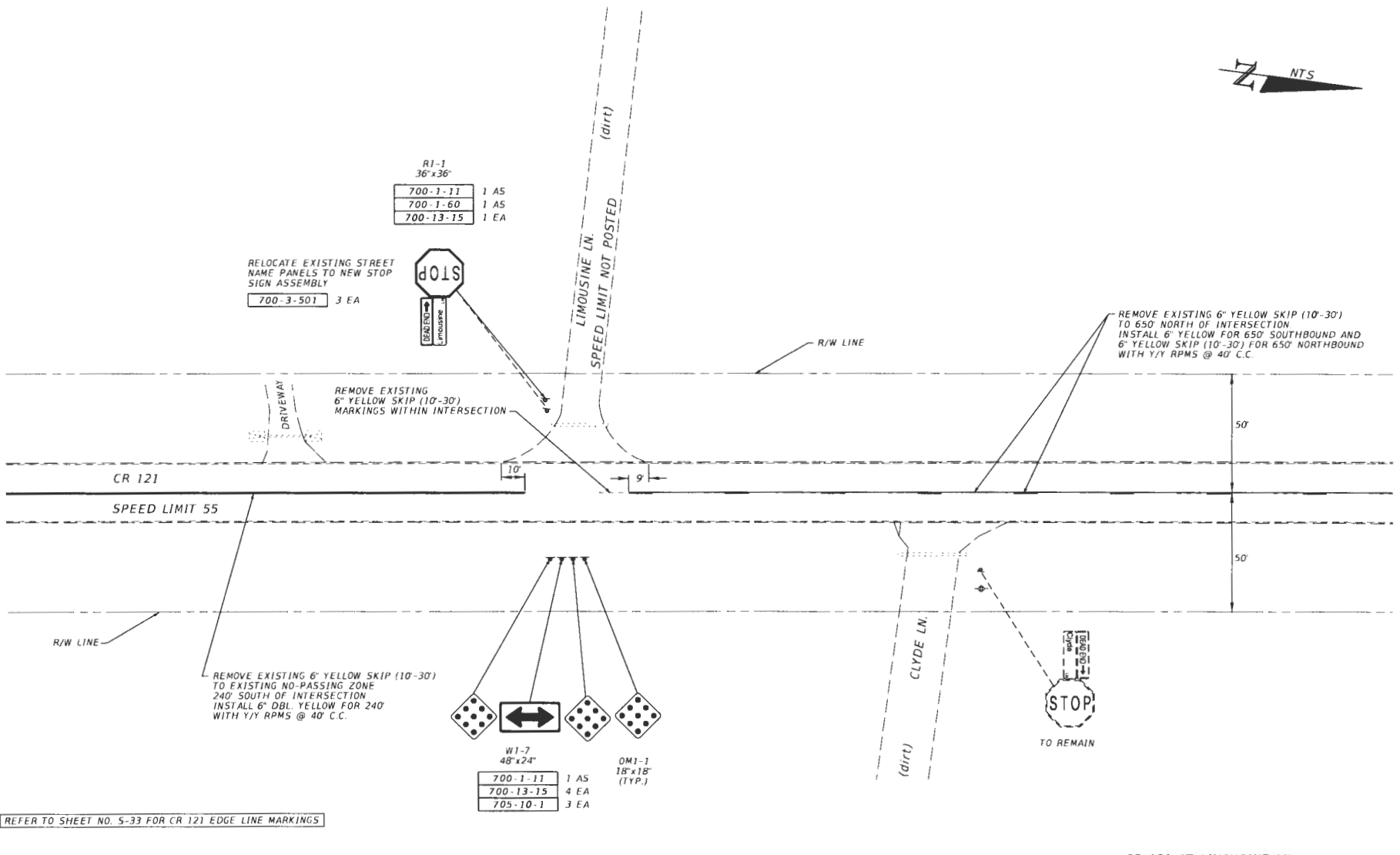

REMOVE EXISTING 6" YELLOW SKIP (10'-30') TO EXISTING NO-PASSING ZONE 240' SOUTH OF INTERSECTION
 INSTALL 6" DBL YELLOW FOR 240' WITH Y/Y RPMS @ 40' C.C.

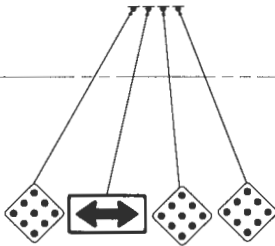

W1-7	48"x24"	
700-1-11	1 AS	
700-13-15	4 EA	
705-10-1	3 EA	
OM1-1	18"x18"	(TYP.)

REMOVE EXISTING 6" YELLOW SKIP (10'-30') TO 650' NORTH OF INTERSECTION
 INSTALL 6" YELLOW FOR 650' SOUTHBOUND AND 6" YELLOW SKIP (10'-30') FOR 650' NORTHBOUND WITH Y/Y RPMS @ 40' C.C.

REFER TO SHEET NO. S-33 FOR CR 121 EDGE LINE MARKINGS

CR 121 AT LIMOUSINE LN.

REVISIONS			
DATE	DESCRIPTION	DATE	DESCRIPTION

Ernest Lee Herbert IV, P.E.
 P.E. License Number 79413
 Comprehensive Engineering Services, Inc.
 201 S Orange Ave., Suite 1300
 Orlando, FL 32801-3442

STATE OF FLORIDA DEPARTMENT OF TRANSPORTATION		
ROAD NO.	COUNTY	FINANCIAL PROJECT ID
CR 121	NASSAU	441217-1-52-01

SIGNING AND PAVEMENT MARKING PLAN

SHEET NO.
5-15

THIS SHEET IS THE ELECTRONIC FILE DIGITALLY SIGNED AND SEALED UNDER RULE 61G15-23.004, F.A.C.
 CONTRACT NO. CM3150
 BID NO. NC21-014

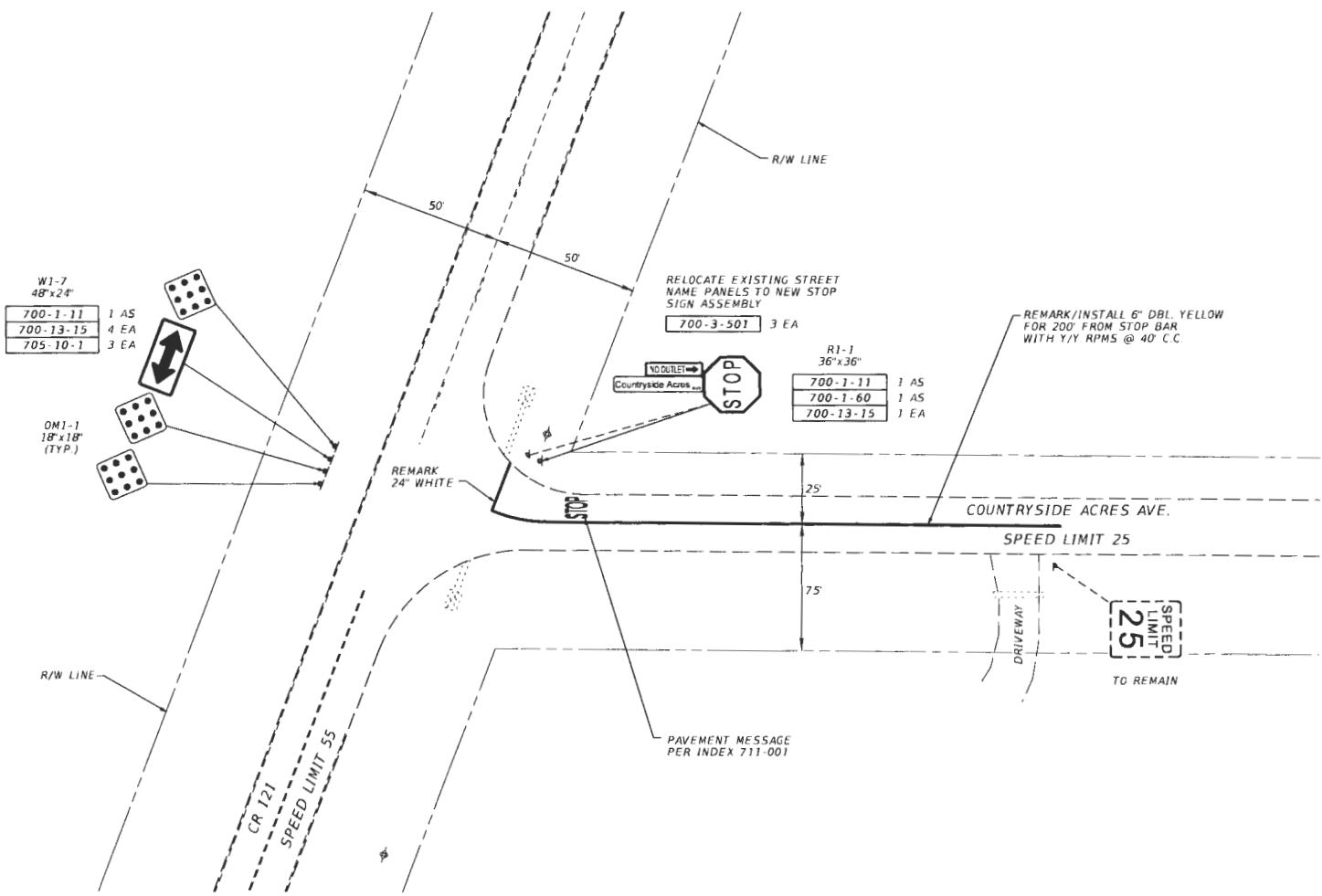

- W1-7
48"x24"
- 700-1-11 1 AS
- 700-13-15 4 EA
- 705-10-1 3 EA

OM1-1
18"x18"
(TYP.)

RELOCATE EXISTING STREET
NAME PANELS TO NEW STOP
SIGN ASSEMBLY

- 700-3-501 3 EA

- R1-1
36"x36"
- 700-1-11 1 AS
- 700-1-60 1 AS
- 700-13-15 1 EA

REMARK/INSTALL 6" DBL. YELLOW
FOR 200' FROM STOP BAR
WITH Y/Y RPMS @ 40' C.C.

COUNTRYSIDE ACRES AVE.

SPEED LIMIT 25

25
SPEED
LIMIT

TO REMAIN

REMARK
24" WHITE

PAVEMENT MESSAGE
PER INDEX 711-001

REFER TO SHEET NO. S-33 FOR CR 121 EDGE LINE MARKINGS

CR 121 AT COUNTRYSIDE ACRES AVE.

REVISIONS	
DATE	DESCRIPTION

Ernest Lee Herbert IV, P.E.
P.E. License Number 79413
Comprehensive Engineering Services, Inc.
201 S Orange Ave, Suite 1300
Orlando, FL 32801-3442

STATE OF FLORIDA DEPARTMENT OF TRANSPORTATION		
ROAD NO.	COUNTY	FINANCIAL PROJECT ID
CR 121	NASSAU	441217-1-52-01

**SIGNING AND PAVEMENT
MARKING PLAN**

SHEET NO.
S-16

THIS SHEET IS THE ELECTRONIC FILE DIGITALLY SIGNED AND SEALED UNDER RULE 61D15-23.001, F.A.C.

Contract No. CM3150

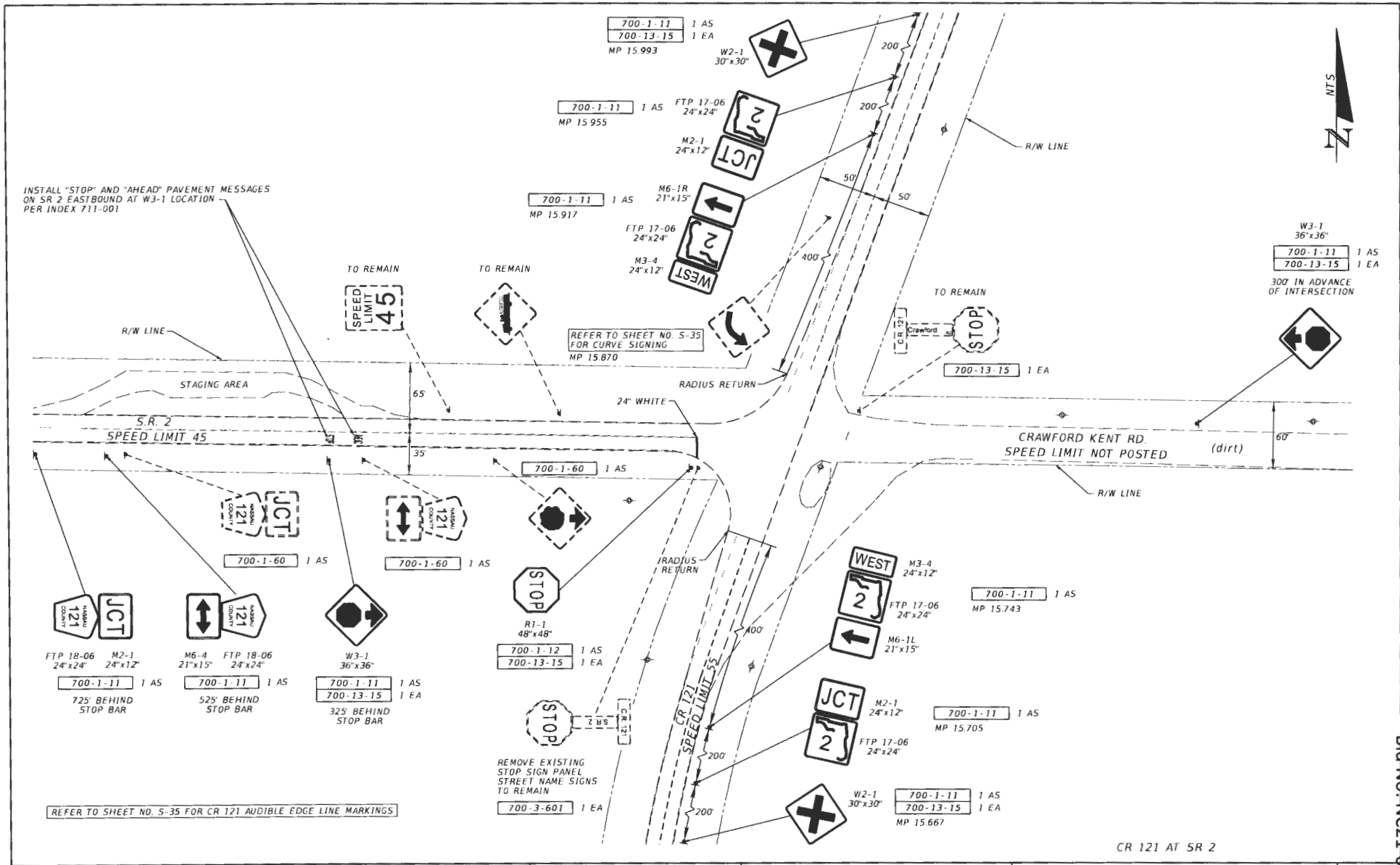

REVISIONS	
DATE	DESCRIPTION

Ernest Lee Horbert IV, P.E.
 P.E. License Number 79413
 Comprehensive Engineering Services, Inc.
 201 S Orange Ave, Suite 1300
 Orlando, FL 32801-3442

STATE OF FLORIDA DEPARTMENT OF TRANSPORTATION		
ROAD NO.	COUNTY	FINANCIAL PROJECT ID
CR 121	NASSAU	441217-1-52-01

**SIGNING AND PAVEMENT
MARKING PLAN**

SHEET NO.
5-17

CONTRACT NO. CM3150
 SHEET 5-17
 THIS SHEET IS THE ELECTRONIC FILE DIGITALLY SIGNED AND SEALED UNDER RULE 61G19-23.004, F.A.C.

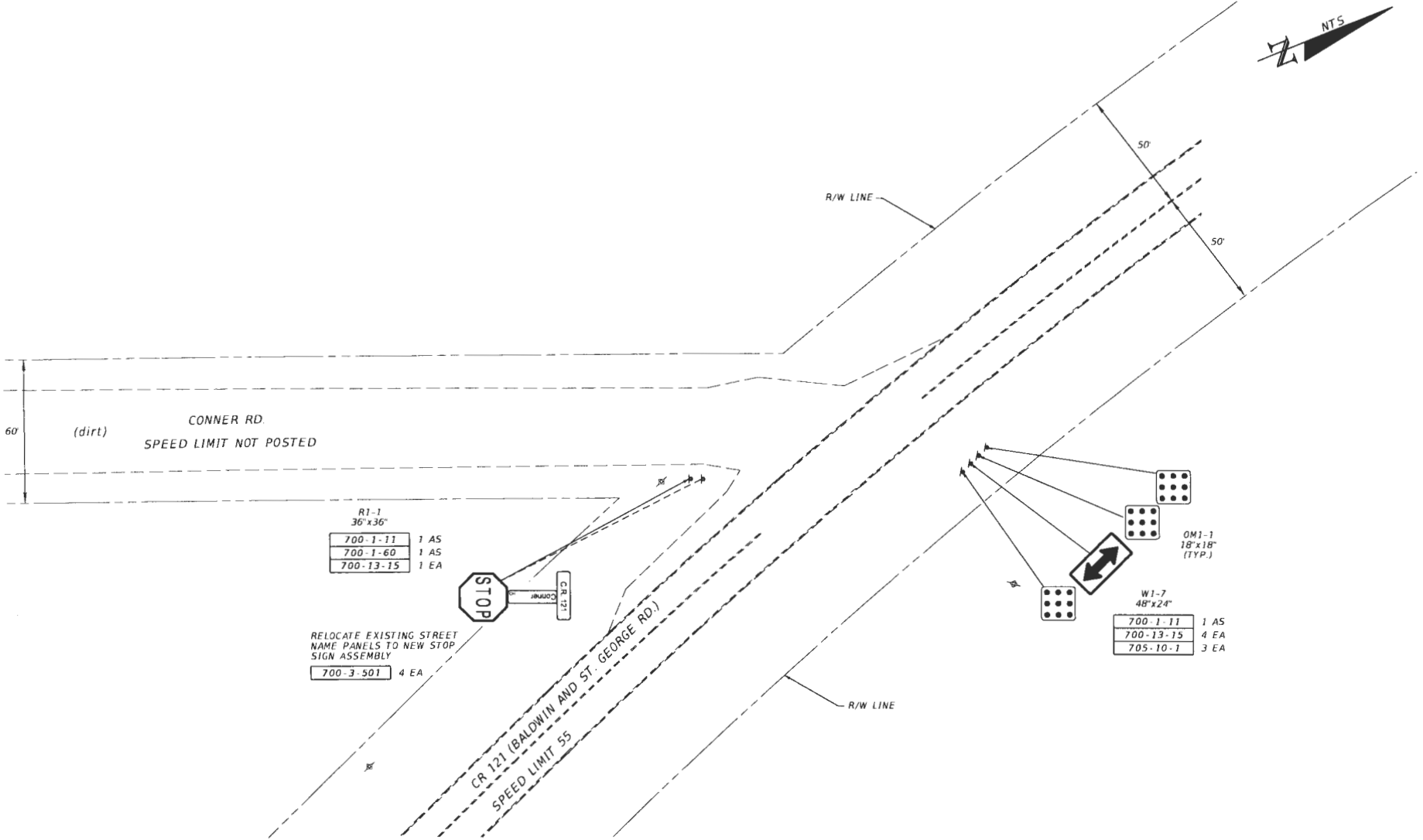
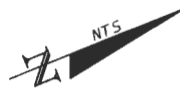

R1-1 36"x36"	
700-1-11	1 AS
700-1-60	1 AS
700-13-15	1 EA

RELOCATE EXISTING STREET NAME PANELS TO NEW STOP SIGN ASSEMBLY

700-3-501	4 EA
-----------	------

W1-7 48"x24"	
700-1-11	1 AS
700-13-15	4 EA
705-10-1	3 EA

OM1-1 18"x18" (TYP.)	
----------------------------	--

CR 121/BALDWIN AND ST. GEORGE RD. AT CONNER RD.

REVISIONS			
DATE	DESCRIPTION	DATE	DESCRIPTION

Ernest Lee Herbert IV, P.E.
P.E. License Number 79413
Comprehensive Engineering Services, Inc.
201 S Orange Ave, Suite 1300
Orlando, FL 32801-3442

STATE OF FLORIDA DEPARTMENT OF TRANSPORTATION		
ROAD NO.	COUNTY	FINANCIAL PROJECT ID
CR 121	NASSAU	441217-1-52-01

**SIGNING AND PAVEMENT
MARKING PLAN**

SHEET NO.
S-18

CONTRACT NO. CM3150
THIS SHEET IS THE ELECTRONIC FILE DIGITALLY SIGNED AND SEALED UNDER RULE 61G15-23.004, F.A.C.

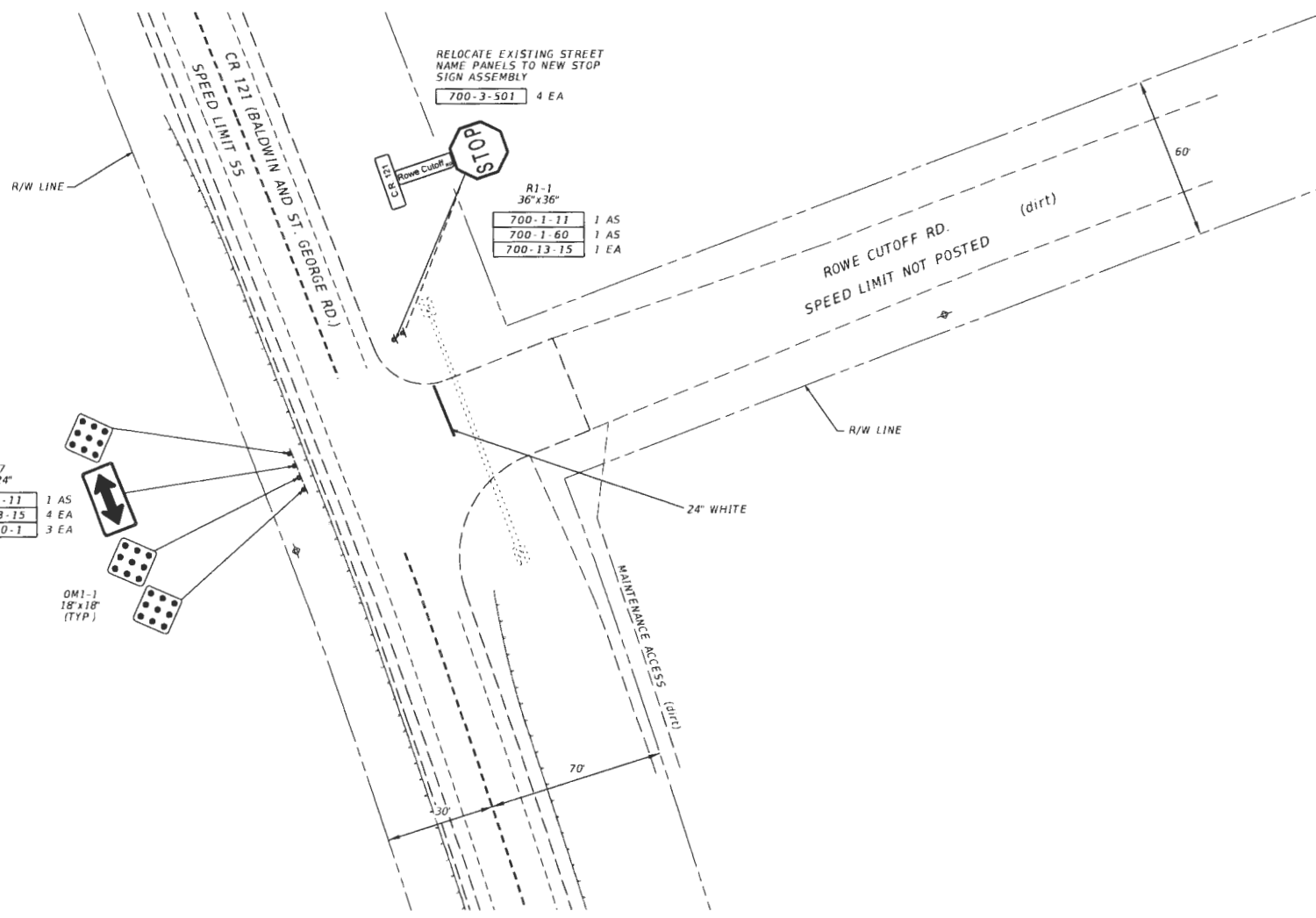

RELOCATE EXISTING STREET
NAME PANELS TO NEW STOP
SIGN ASSEMBLY
700-3-501 4 EA

R1-1
36"x36"
700-1-11 1 AS
700-1-60 1 AS
700-13-15 1 EA

W1-7
48"x24"
700-1-11 1 AS
700-13-15 4 EA
705-10-1 3 EA

OM1-1
18"x18"
(TYP)

CR 121/BALDWIN AND ST. GEORGE RD. AT ROWE CUTOFF RD.

REVISIONS	
DATE	DESCRIPTION

Ernest Lee Herbert IV, P.E.
P.E. License Number 79413
Comprehensive Engineering Services, Inc.
201 S Orange Ave, Suite 1300
Orlando, FL 32801-3442

STATE OF FLORIDA DEPARTMENT OF TRANSPORTATION		
ROAD NO.	COUNTY	FINANCIAL PROJECT ID
CR 121	NASSAU	441217-1-52-01

**SIGNING AND PAVEMENT
MARKING PLAN**

SHEET NO.
S-19

THIS SHEET IS THE ELECTRONIC FILE DIGITALLY SIGNED AND SEALED UNDER RULE 61G15-23.004, F.A.C.
 DATE: 11/18/2021 4:22:16 PM
 PROJECT: S:\3500807\441217\5201\signing\plans\12.dgn

Contract No. CM3150
 SHEET NO. S-19 OF 19

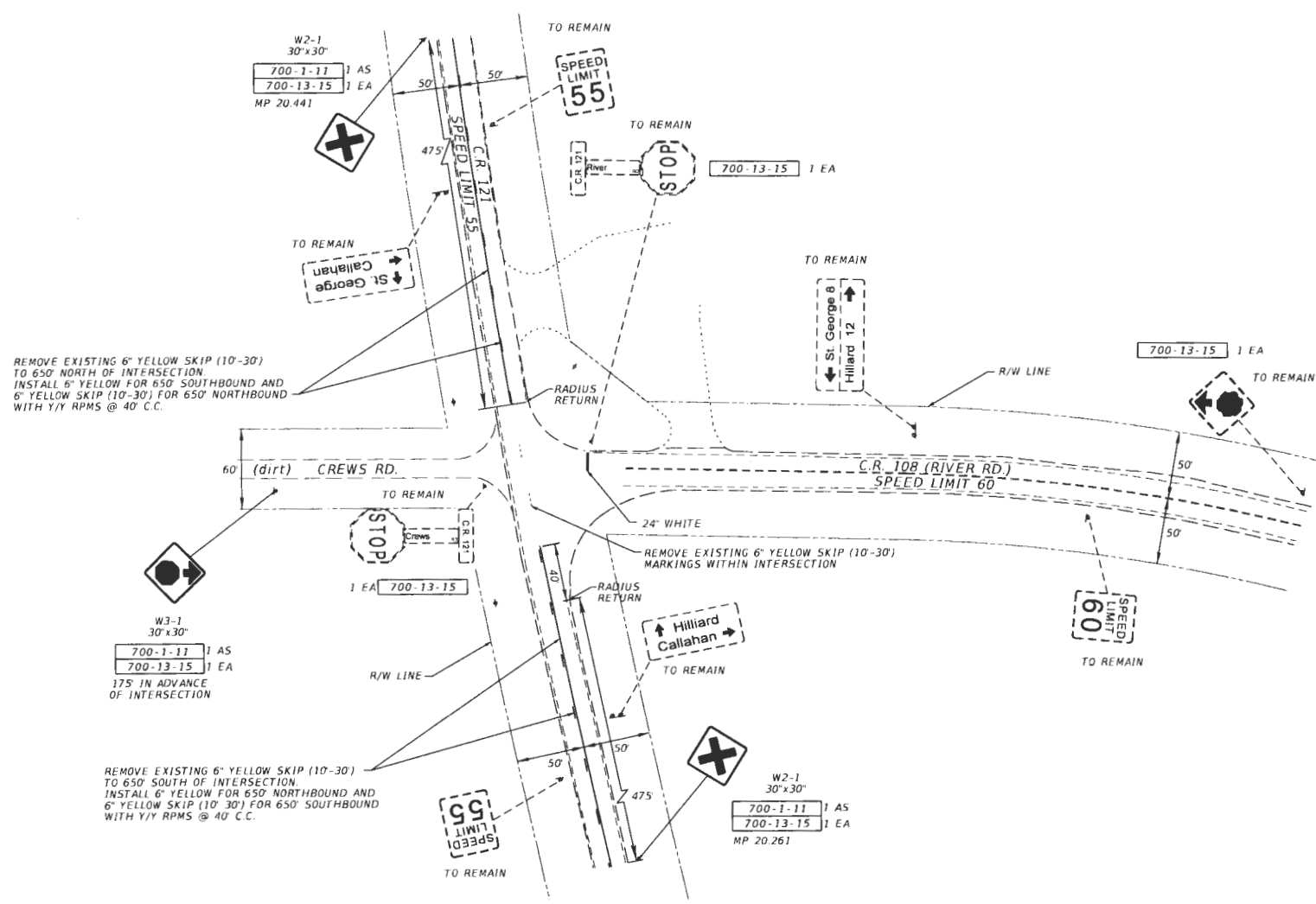

REMOVE EXISTING 6" YELLOW SKIP (10'-30') TO 650' NORTH OF INTERSECTION
 INSTALL 6" YELLOW FOR 650' SOUTHBOUND AND 6" YELLOW SKIP (10'-30') FOR 650' NORTHBOUND WITH Y/Y RPMS @ 40' C.C.

W3-1
 30"x30"
 700-1-11 1 AS
 700-13-15 1 EA
 175' IN ADVANCE OF INTERSECTION

REMOVE EXISTING 6" YELLOW SKIP (10'-30') TO 650' SOUTH OF INTERSECTION
 INSTALL 6" YELLOW FOR 650' NORTHBOUND AND 6" YELLOW SKIP (10'-30') FOR 650' SOUTHBOUND WITH Y/Y RPMS @ 40' C.C.

CR 121 AT CR 108/RIVER RD.

REVISIONS	
DATE	DESCRIPTION

Ernest Lee Herbert IV, P.E.
 P.E. License Number 79413
 Comprehensive Engineering Services, Inc.
 201 S Orange Ave, Suite 1300
 Orlando, FL 32801-3442

STATE OF FLORIDA DEPARTMENT OF TRANSPORTATION		
ROAD NO.	COUNTY	FINANCIAL PROJECT ID
CR 121	NASSAU	441217-1-52-01

**SIGNING AND PAVEMENT
 MARKING PLAN**

SHEET NO.
5-20

Contract No. CM3150
 THIS SHEET IS THE ELECTRONIC FILE DIGITALLY SIGNED AND SEALED UNDER RULE 61G15-23.004, F.A.C.
 11/18/2021 4:22:17 PM I:\Projects\1500807\44121715201\signing\plansp29.dgn

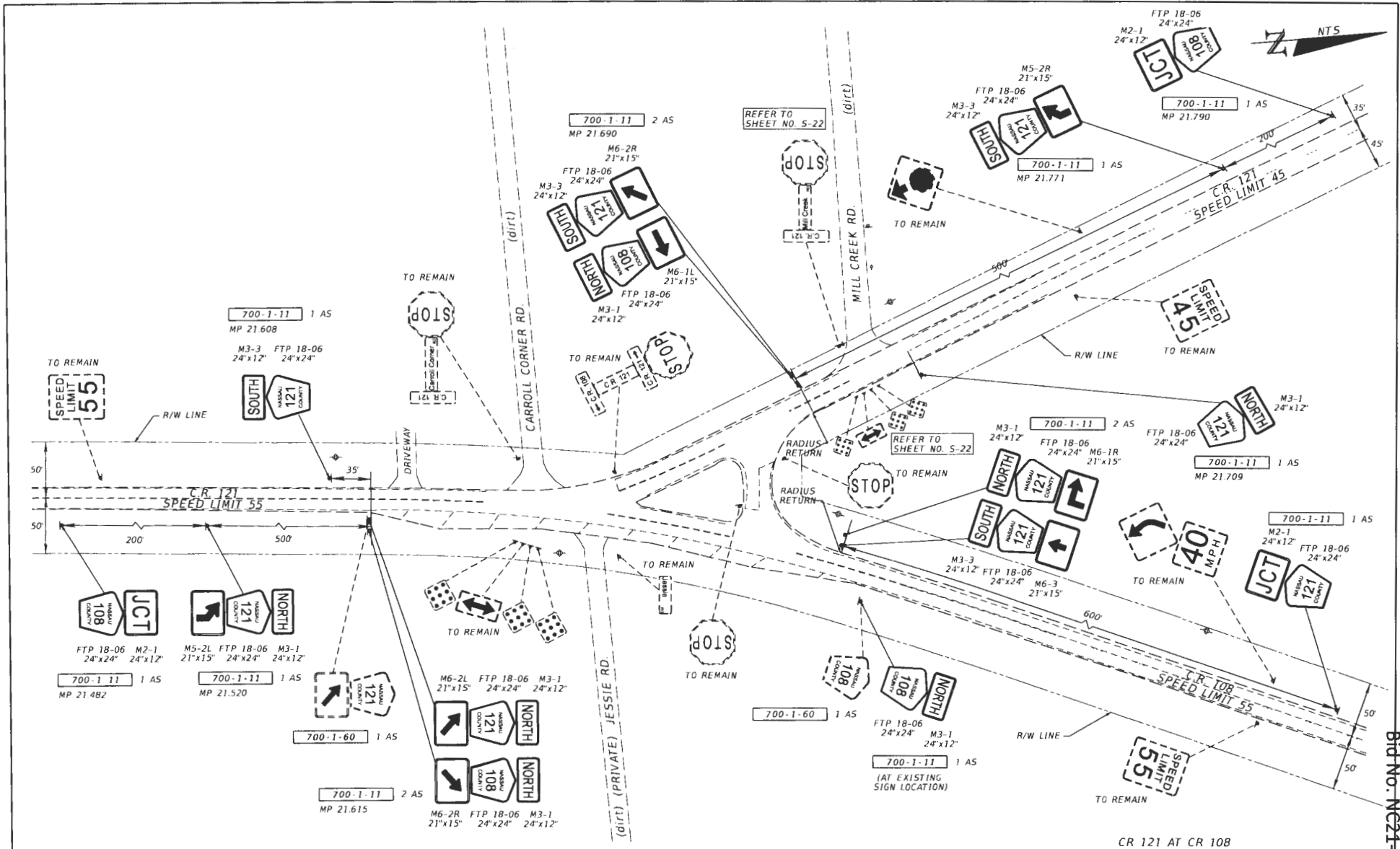

CR 121 AT CR 108

REVISIONS		REVISIONS	
DATE	DESCRIPTION	DATE	DESCRIPTION

Ernest Lee Herbert IV, P.E.
 P.E. License Number 79413
 Comprehensive Engineering Services, Inc.
 201 S Orange Ave, Suite 1300
 Orlando, FL 32801-3442

STATE OF FLORIDA DEPARTMENT OF TRANSPORTATION		
ROAD NO	COUNTY	FINANCIAL PROJECT ID
CR 121	NASSAU	441217-1-52-01

**SIGNING AND PAVEMENT
MARKING PLAN**

SHEET NO.
5-21

Contract No. CM3150
 Bid No. NC21-014
 THE OFFICIAL RECORD OF THIS SHEET IS THE ELECTRONIC FILE DIGITALLY SIGNED AND SEALED UNDER RULE 61G15-23.004, F.A.C.

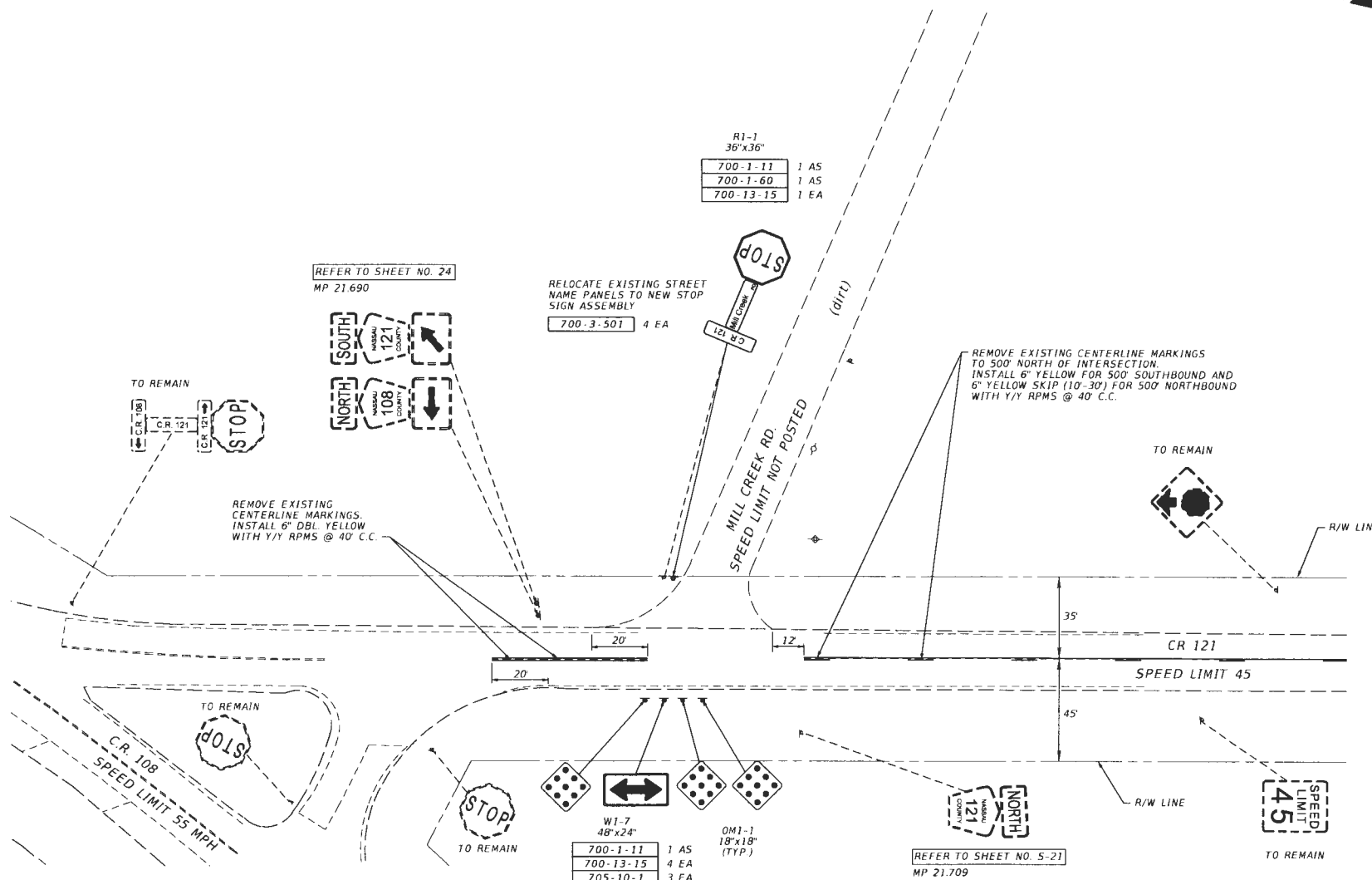

REFER TO SHEET NO. 24
MP 21.690

RELOCATE EXISTING STREET
NAME PANELS TO NEW STOP
SIGN ASSEMBLY
700-3-501 4 EA

R1-1
36"x36"
700-1-11 1 AS
700-1-60 1 AS
700-13-15 1 EA

REMOVE EXISTING CENTERLINE MARKINGS
TO 500' NORTH OF INTERSECTION.
INSTALL 6" YELLOW FOR 500' SOUTHBOUND AND
6" YELLOW SKIP (10'-30') FOR 500' NORTHBOUND
WITH Y/Y RPMS @ 40' C.C.

REMOVE EXISTING
CENTERLINE MARKINGS.
INSTALL 6" DBL-YELLOW
WITH Y/Y RPMS @ 40' C.C.

W1-7
48"x24"
700-1-11 1 AS
700-13-15 4 EA
705-10-1 3 EA

OM1-1
18"x18"
(TYP)

REFER TO SHEET NO. S-21
MP 21.709

CR 121/FREDDIE GEIGER RD. AT MILL CREEK RD.

REVISIONS	
DATE	DESCRIPTION

Ernest Lee Herben IV, P.E.
P.E. License Number 79413
Comprehensive Engineering Services, Inc.
201 S Orange Ave, Suite 1300
Orlando, FL 32801-3442

STATE OF FLORIDA DEPARTMENT OF TRANSPORTATION		
ROAD NO.	COUNTY	FINANCIAL PROJECT ID
CR 121	NASSAU	441217-1-52-01

**SIGNING AND PAVEMENT
MARKING PLAN**

SHEET NO.	S-22
-----------	------

EHerbert

1/11/2021

4:22:18 PM

T:\Project\1500807\441217\15201\signing\plansp.00.dgn

Contract No. CM3150
BID NO. NC21-014
THIS SHEET IS THE ELECTRONIC FILE DIGITALLY SIGNED AND SEALED UNDER RULE 61G15-23.004, F.A.C.

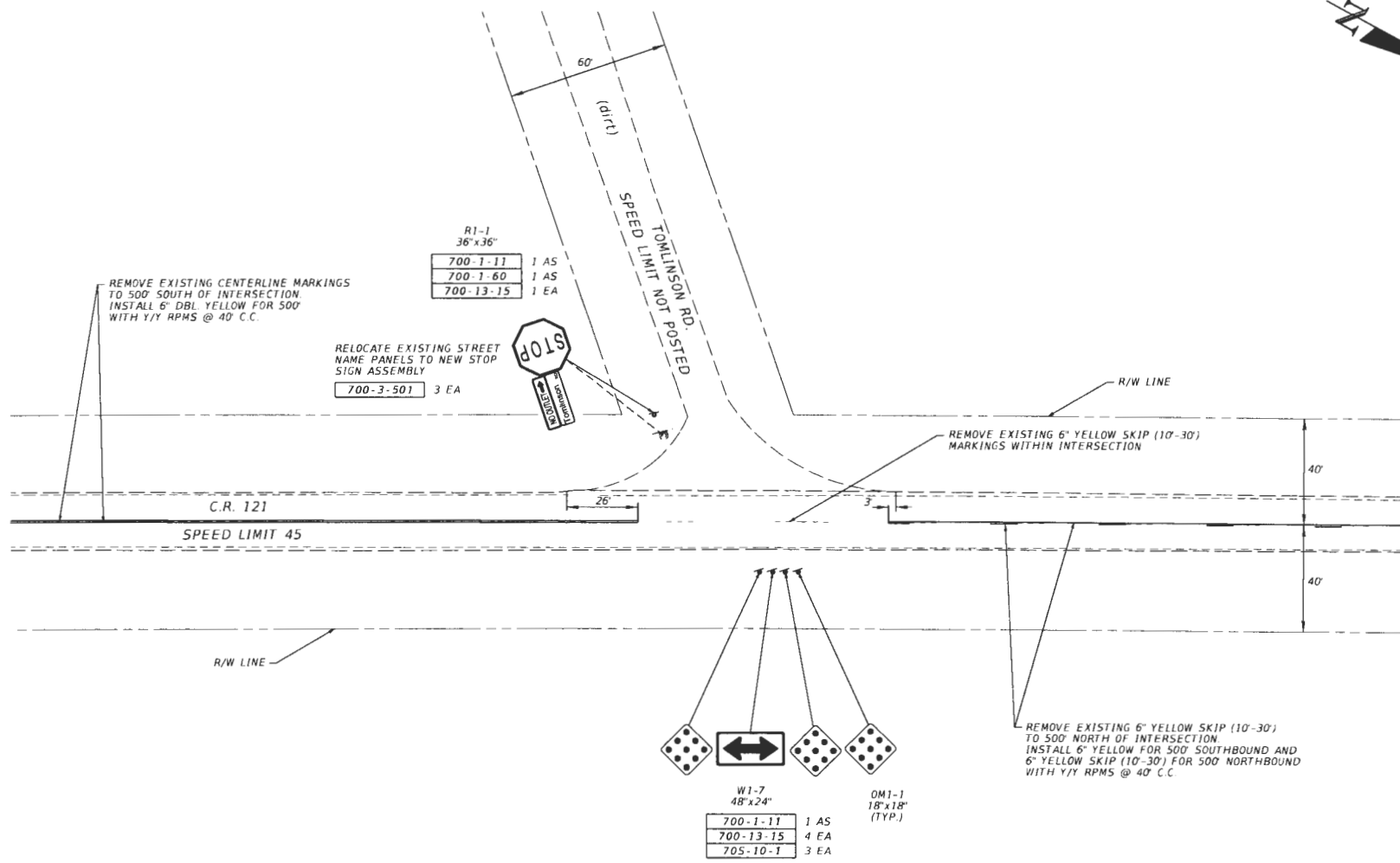
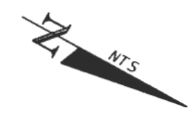

CR 121 AT TOMLINSON RD.

REVISIONS				Ernest Lee Herbert IV, P.E. P.E. License Number 79413 Comprehensive Engineering Services, Inc. 201 S Orange Ave, Suite 1300 Orlando, FL 32801-3442	STATE OF FLORIDA DEPARTMENT OF TRANSPORTATION			SIGNING AND PAVEMENT MARKING PLAN	SHEET NO. S-23
DATE	DESCRIPTION	DATE	DESCRIPTION		ROAD NO.	COUNTY	FINANCIAL PROJECT ID		
					CR 121	NASSAU	441217-1-52-01		

THIS SHEET IS THE ELECTRONIC FILE DIGITALLY SIGNED AND SEALED UNDER RULE 61G15-23.004, F.A.C.
 CONTRACT NO. CM3150
 SHEET NO. S-23 OF 24

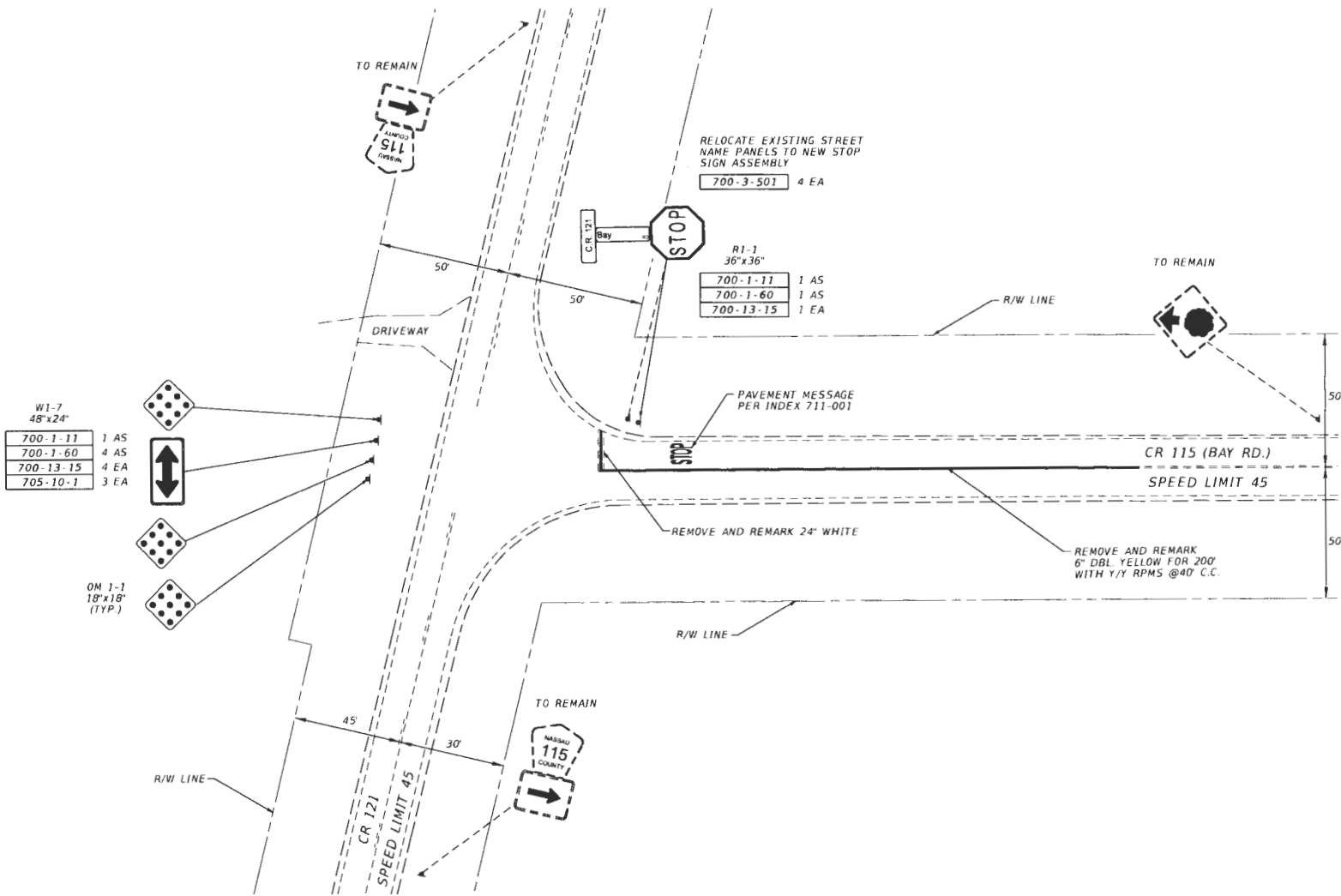

W1-7	48"x24"	
700-1-11		1 AS
700-1-60		4 AS
700-13-15		4 EA
705-10-1		3 EA

RELOCATE EXISTING STREET NAME PANELS TO NEW STOP SIGN ASSEMBLY
700-3-501 4 EA

R1-1	36"x36"	
700-1-11		1 AS
700-1-60		1 AS
700-13-15		1 EA

CR 121 AT CR 115/BAY RD.

REVISIONS			
DATE	DESCRIPTION	DATE	DESCRIPTION

Ernest Lee Herbert IV, P.E.
P.E. License Number 79413
Comprehensive Engineering Services, Inc.
201 S Orange Ave, Suite 1300
Orlando, FL 32801-3442

STATE OF FLORIDA DEPARTMENT OF TRANSPORTATION		
ROAD NO	COUNTY	FINANCIAL PROJECT ID
CR 121	NASSAU	441217-1-52-01

SIGNING AND PAVEMENT MARKING PLAN

SHEET NO.
S-24

Contract No. CM3150
 Bid No. NC21-014
 THE OFFICIAL RECORD OF THIS SHEET IS THE ELECTRONIC FILE DIGITALLY SIGNED AND SEALED UNDER RULE 61G15-23.004, F.A.C.



SOUTHBOUND:
 REMOVE EXISTING 6" YELLOW SKIP (10'-30')
 TO 65' NORTH OF INTERSECTION.
 INSTALL 6" YELLOW FOR 65'
 WITH Y/Y RPMS @40' C.C.

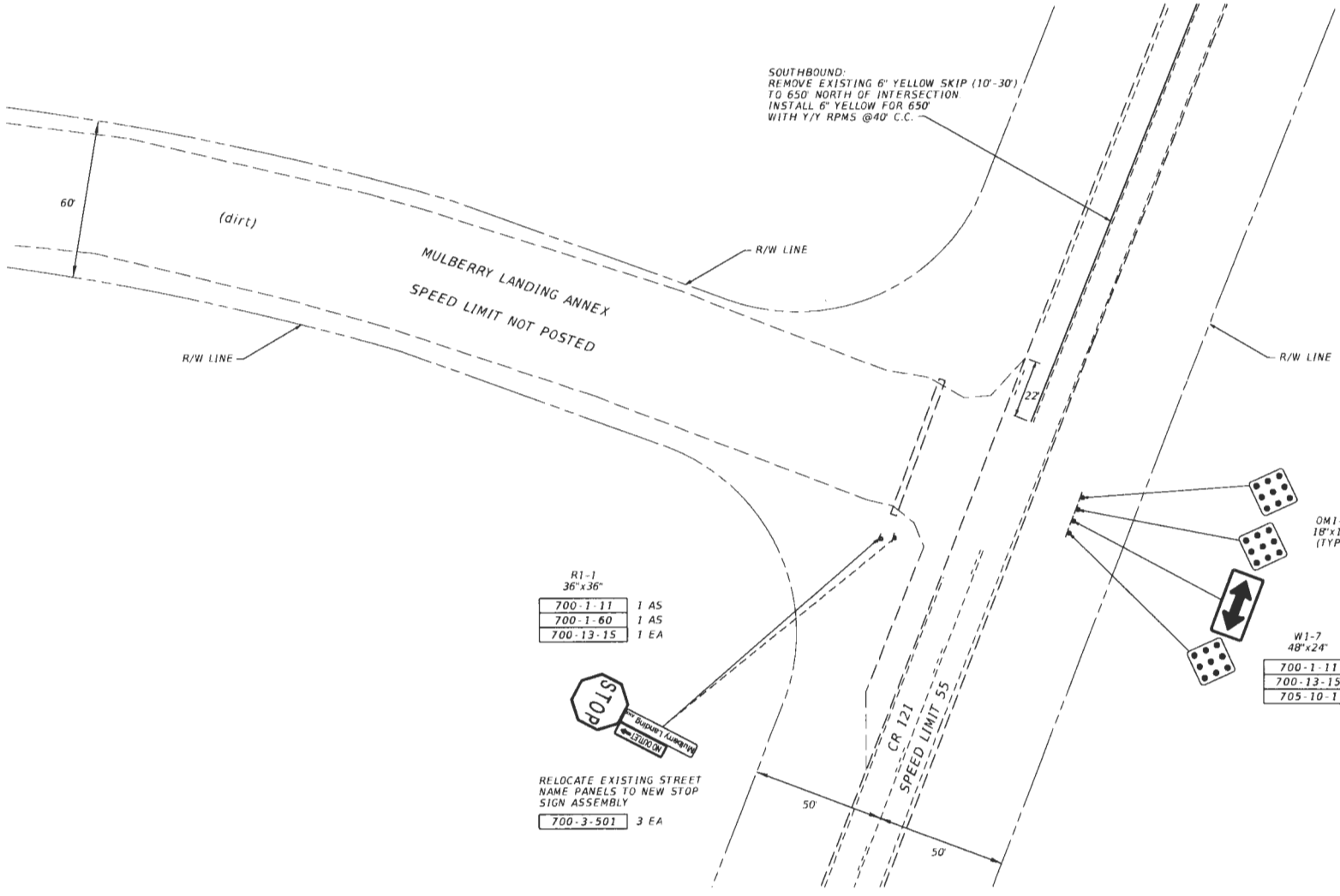

R1-1	36" x 36"	
700-1-11		1 AS
700-1-60		1 AS
700-13-15		1 EA

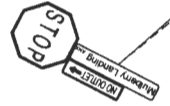

RELOCATE EXISTING STREET
 NAME PANELS TO NEW STOP
 SIGN ASSEMBLY

700-3-501	3 EA
-----------	------

OMI-1	18" x 18"	(TYP.)	
W1-7	48" x 24"		
700-1-11		1 AS	
700-13-15		4 EA	
705-10-1		3 EA	

CR 121 AT MULBERRY LANDING ANNEX

REVISIONS			
DATE	DESCRIPTION	DATE	DESCRIPTION

Ernest Lee Herbert IV, P.E.
 P.E. License Number 79413
 Comprehensive Engineering Services, Inc.
 201 S Orange Ave, Suite 1300
 Orlando, FL 32801-3442

STATE OF FLORIDA DEPARTMENT OF TRANSPORTATION		
ROAD NO.	COUNTY	FINANCIAL PROJECT ID
CR 121	NASSAU	441217-1-52-01

**SIGNING AND PAVEMENT
 MARKING PLAN**

SHEET NO.
S-25

Contract No. CM3150
 Bid No. NC21-014
 THIS SHEET IS THE ELECTRONIC FILE DIGITALLY SIGNED AND SEALED UNDER RULE 61G15-23.004, F.A.C.

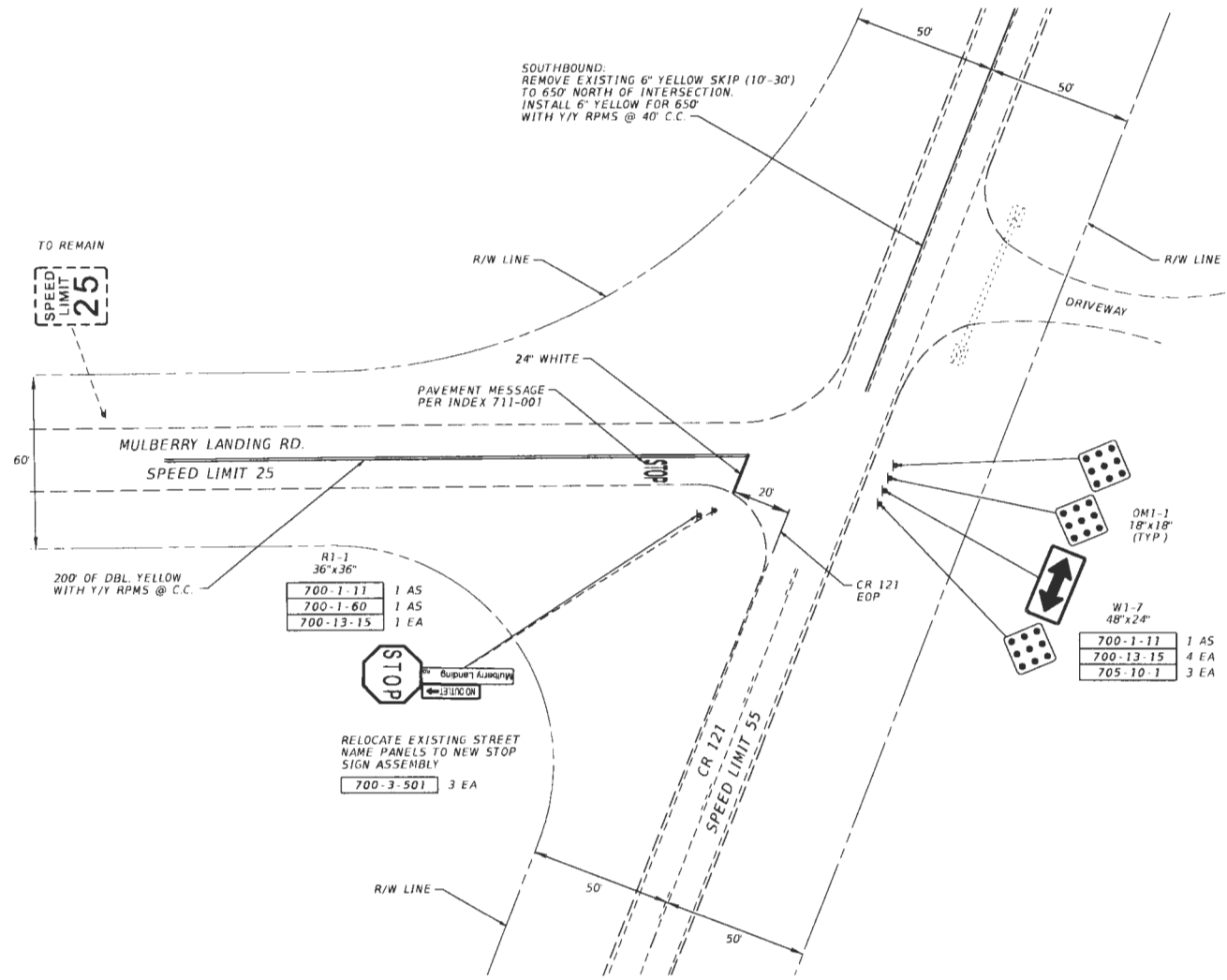

TO REMAIN
SPEED LIMIT 25

MULBERRY LANDING RD.
SPEED LIMIT 25

200' OF DBL. YELLOW WITH Y/Y RPMS @ C.C.

R1-1 36" x 36"	
700-1-11	1 AS
700-1-60	1 AS
700-13-15	1 EA



RELOCATE EXISTING STREET NAME PANELS TO NEW STOP SIGN ASSEMBLY
700-3-501 3 EA

SOUTHBOUND:
REMOVE EXISTING 6" YELLOW SKIP (10'-30') TO 650' NORTH OF INTERSECTION.
INSTALL 6" YELLOW FOR 650' WITH Y/Y RPMS @ 40' C.C.

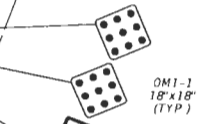

W1-7 48" x 2-4"	
700-1-11	1 AS
700-13-15	4 EA
705-10-1	3 EA

OM1-1
18" x 18"
(TYP)

CR 121 AT MULBERRY LANDING RD.

REVISIONS			
DATE	DESCRIPTION	DATE	DESCRIPTION

Ernest Lee Herbert IV, P.E.
P.E. License Number 79413
Comprehensive Engineering Services, Inc.
201 S Orange Ave, Suite 1300
Orlando, FL 32801-3442

STATE OF FLORIDA DEPARTMENT OF TRANSPORTATION		
ROAD NO.	COUNTY	FINANCIAL PROJECT ID
CR 121	NASSAU	441217-1-52-01

SIGNING AND PAVEMENT MARKING PLAN

SHEET NO.
5-26

Contract No. CM3150
SHEET NO. NC21-014
THE OFFICIAL RECORD OF THIS SHEET IS THE ELECTRONIC FILE DIGITALLY SIGNED AND SEALED UNDER RULE 61G15-23.004, F.A.C.

CONTRACT NO. CM3150
 SHEET 15 THE ELECTRONIC FILE DIGITALLY SIGNED AND SEALED UNDER RULE 61G15-23.004, F.A.C.
 DATE: 11/18/2021
 TIME: 4:22:21 PM

Contract No. CM3150
 SHEET NO. S-27

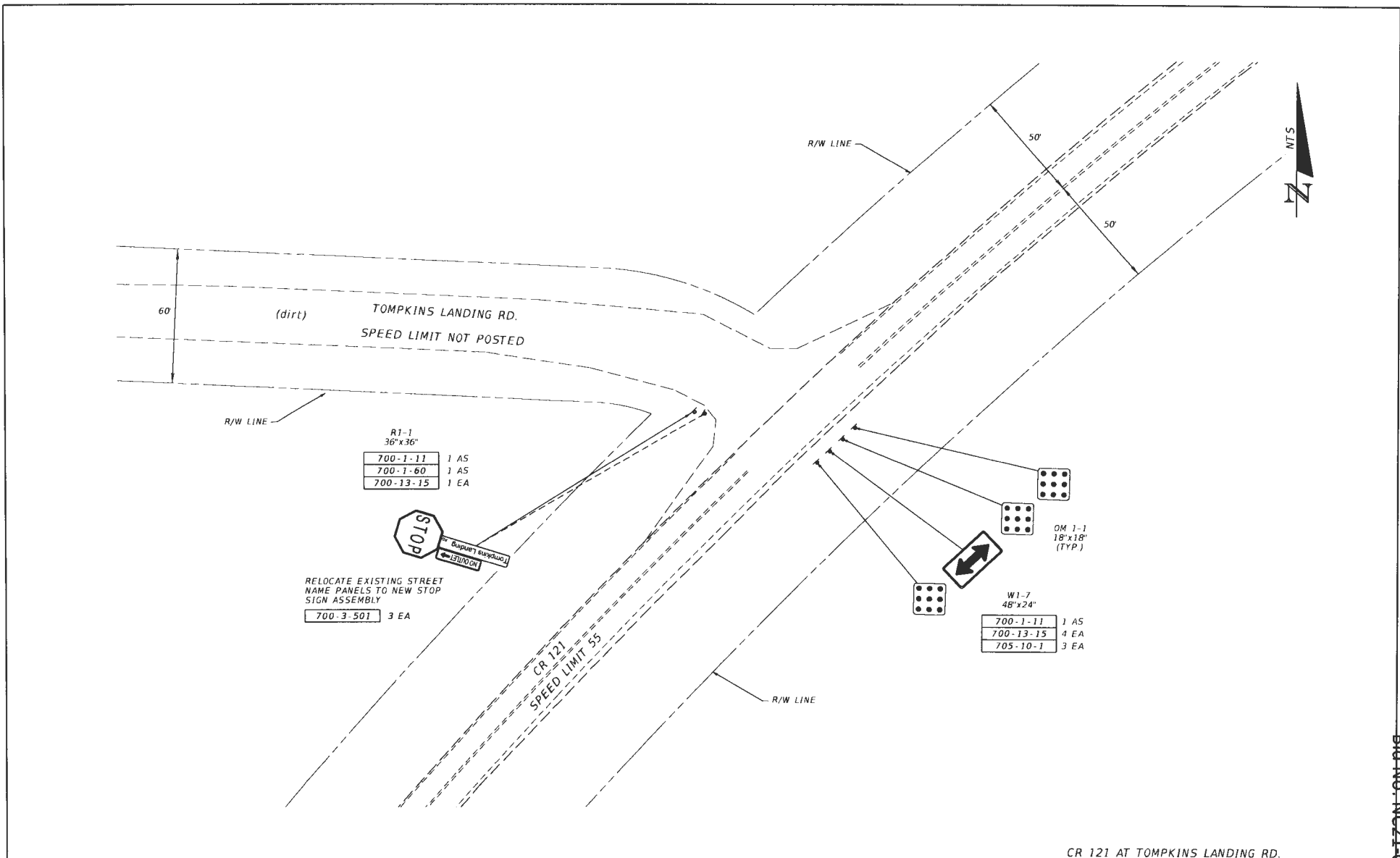

CR 121 AT TOMPKINS LANDING RD.

REVISIONS		DESCRIPTION	DATE	DATE	DESCRIPTION
DATE	DESCRIPTION				

Ernest Lee Herbert IV, P.E.
 P.E. License Number 79413
 Comprehensive Engineering Services, Inc.
 201 S Orange Ave, Suite 1300
 Orlando, FL 32801-3442

STATE OF FLORIDA DEPARTMENT OF TRANSPORTATION		
ROAD NO.	COUNTY	FINANCIAL PROJECT ID
CR 121	NASSAU	441217-1-52-01

**SIGNING AND PAVEMENT
MARKING PLAN**

SHEET NO.	S-27
-----------	------

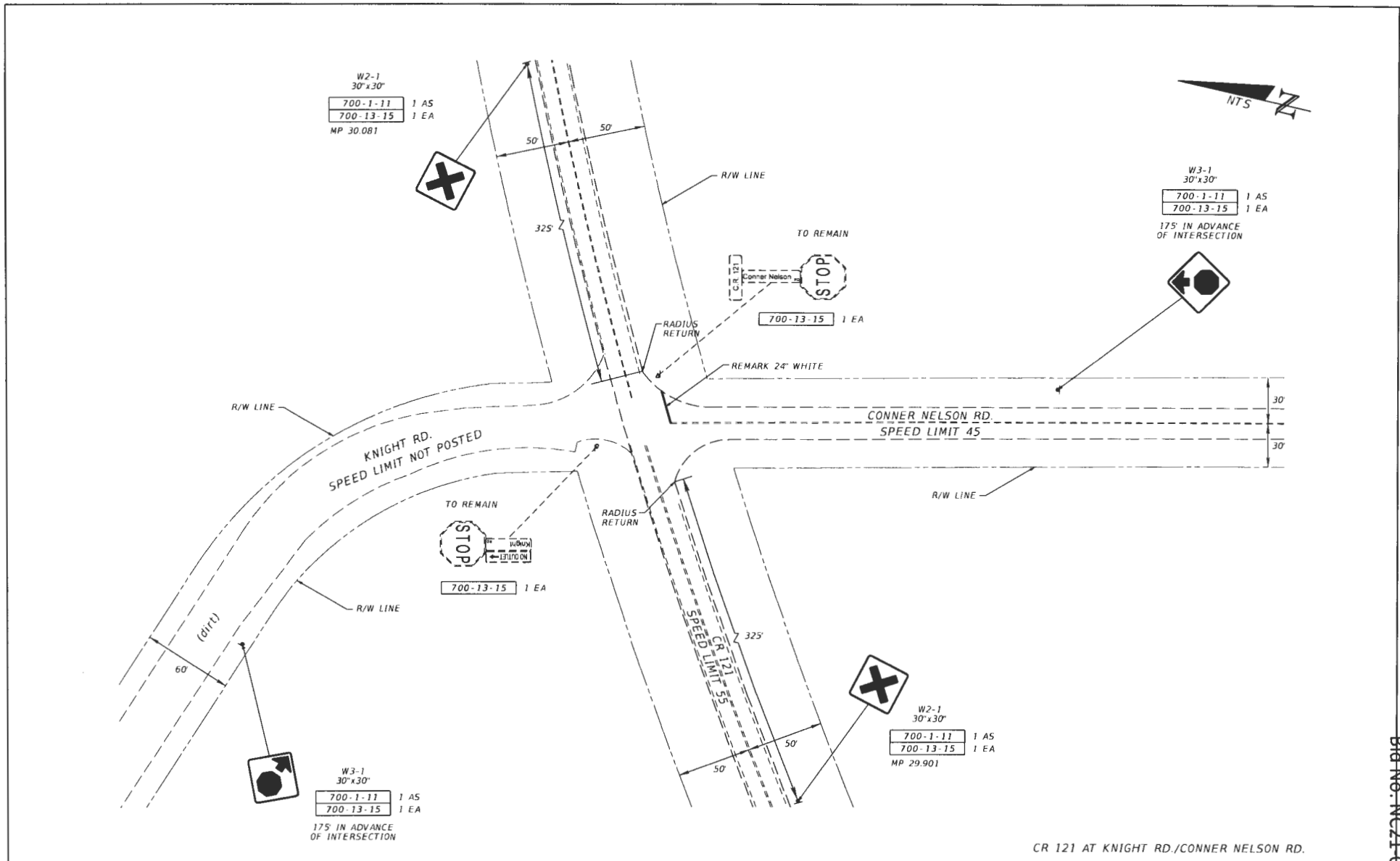

CR 121 AT KNIGHT RD./CONNER NELSON RD.

REVISIONS	
DATE	DESCRIPTION

Ernest Lee Herbert IV, P.E.
P.E. License Number 79413
Comprehensive Engineering Services, Inc.
201 S Orange Ave, Suite 1300
Orlando, FL 32801-3442

STATE OF FLORIDA DEPARTMENT OF TRANSPORTATION		
ROAD NO.	COUNTY	FINANCIAL PROJECT ID
CR 121	NASSAU	441217-1-52-01

SIGNING AND PAVEMENT MARKING PLAN		SHEET NO.
		S-28

THIS SHEET IS THE ELECTRONIC FILE DIGITALLY SIGNED AND SEALED UNDER RULE 61G15-23.004, F.A.C.
 FILE NO. NC21-014

Contract No. CM3150

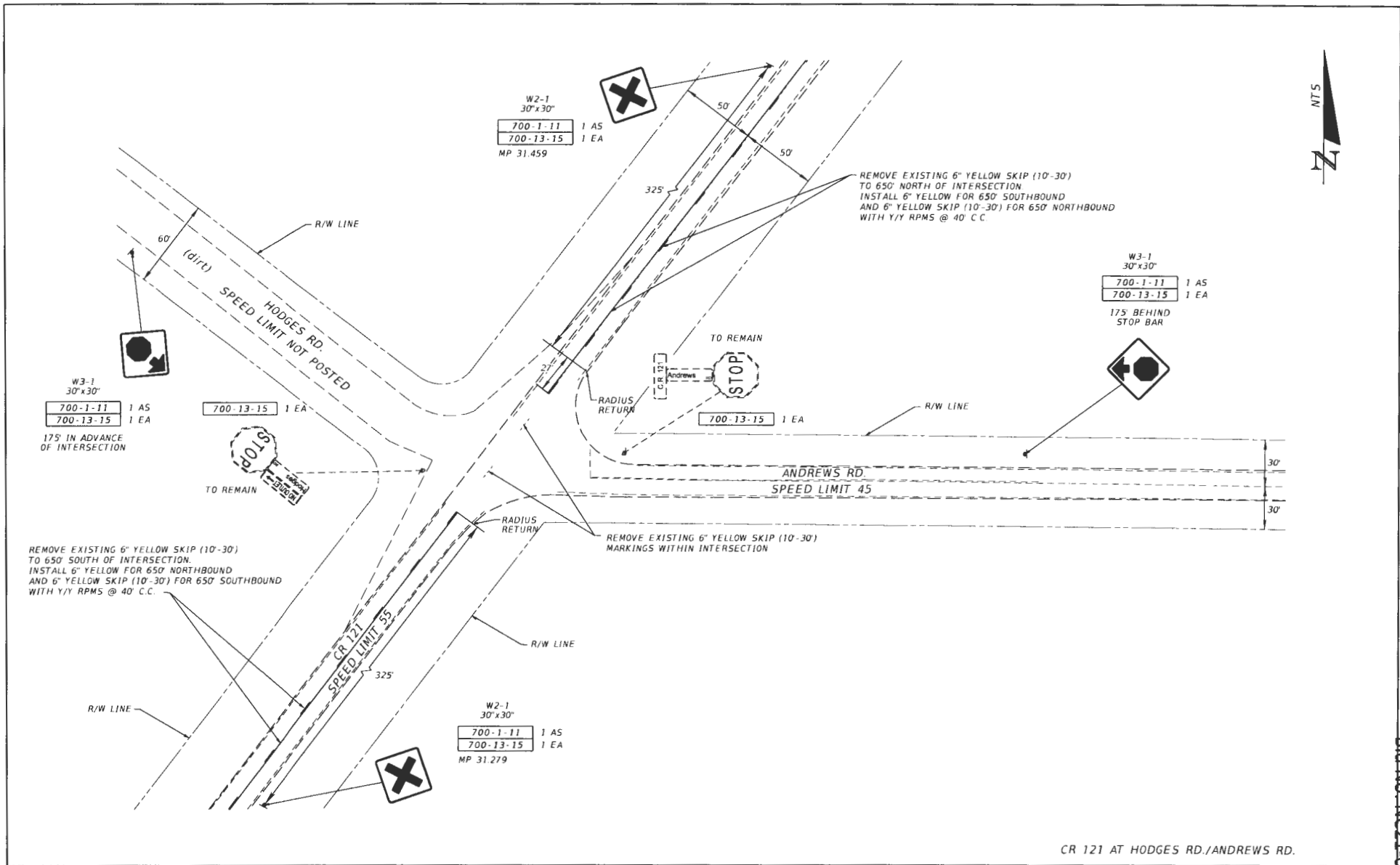

CR 121 AT HODGES RD./ANDREWS RD.

REVISIONS			
DATE	DESCRIPTION	DATE	DESCRIPTION

Ernest Lee Herbert IV, P.E.
 P.E. License Number 78413
 Comprehensive Engineering Services, Inc.
 201 S Orange Ave, Suite 1300
 Orlando, FL 32801-3442

STATE OF FLORIDA DEPARTMENT OF TRANSPORTATION		
ROAD NO.	COUNTY	FINANCIAL PROJECT ID
CR 121	NASSAU	441217-1-52-01

**SIGNING AND PAVEMENT
MARKING PLAN**

SHEET NO.
S-29

Contract No. CM3150
 THIS SHEET IS THE ELECTRONIC FILE DIGITALLY SIGNED AND SEALED UNDER RULE 61G15-23.004, F.A.C.
 11/18/2021 4:22:22 PM

BID NO. NC21-01A
 RECONSTRUCTION OF CR 121
 SHEET 5 OF 5 SHEET IS THE ELECTRONIC FILE DIGITALLY SIGNED AND SEALED UNDER RULE 61G15-23.004, F.A.C.

Contract No. CM3150

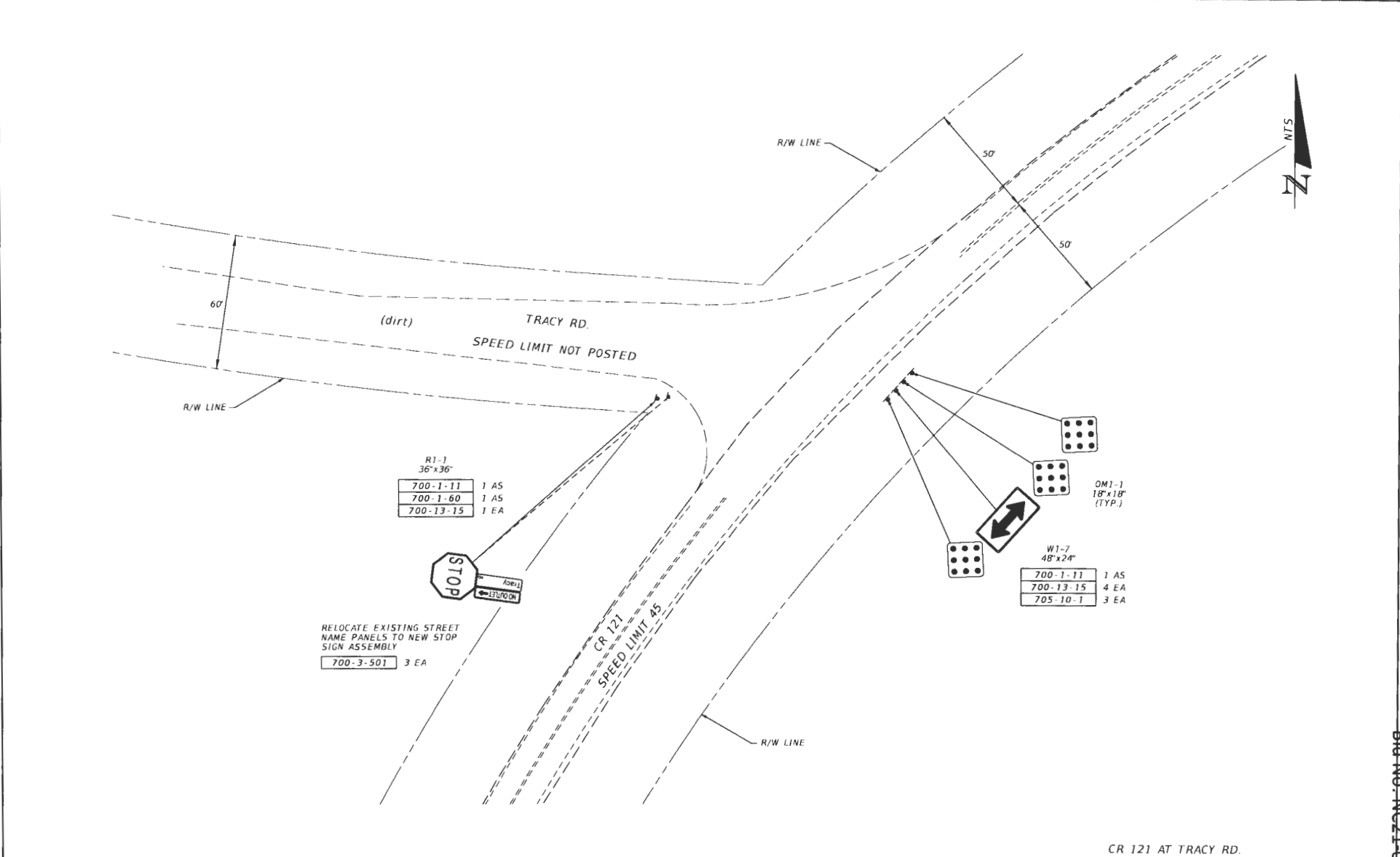

CR 121 AT TRACY RD.

REVISIONS		Ernest Lee Herbert IV, P.E. P.E. License Number 79413 Comprehensive Engineering Services, Inc. 201 S Orange Ave, Suite 1300 Orlando, FL 32801-3442	STATE OF FLORIDA DEPARTMENT OF TRANSPORTATION			SIGNING AND PAVEMENT MARKING PLAN	SHEET NO. S-30
DATE	DESCRIPTION		ROAD NO.	COUNTY	FINANCIAL PROJECT ID		
			CR 121	NASSAU	441217-1-52-01		

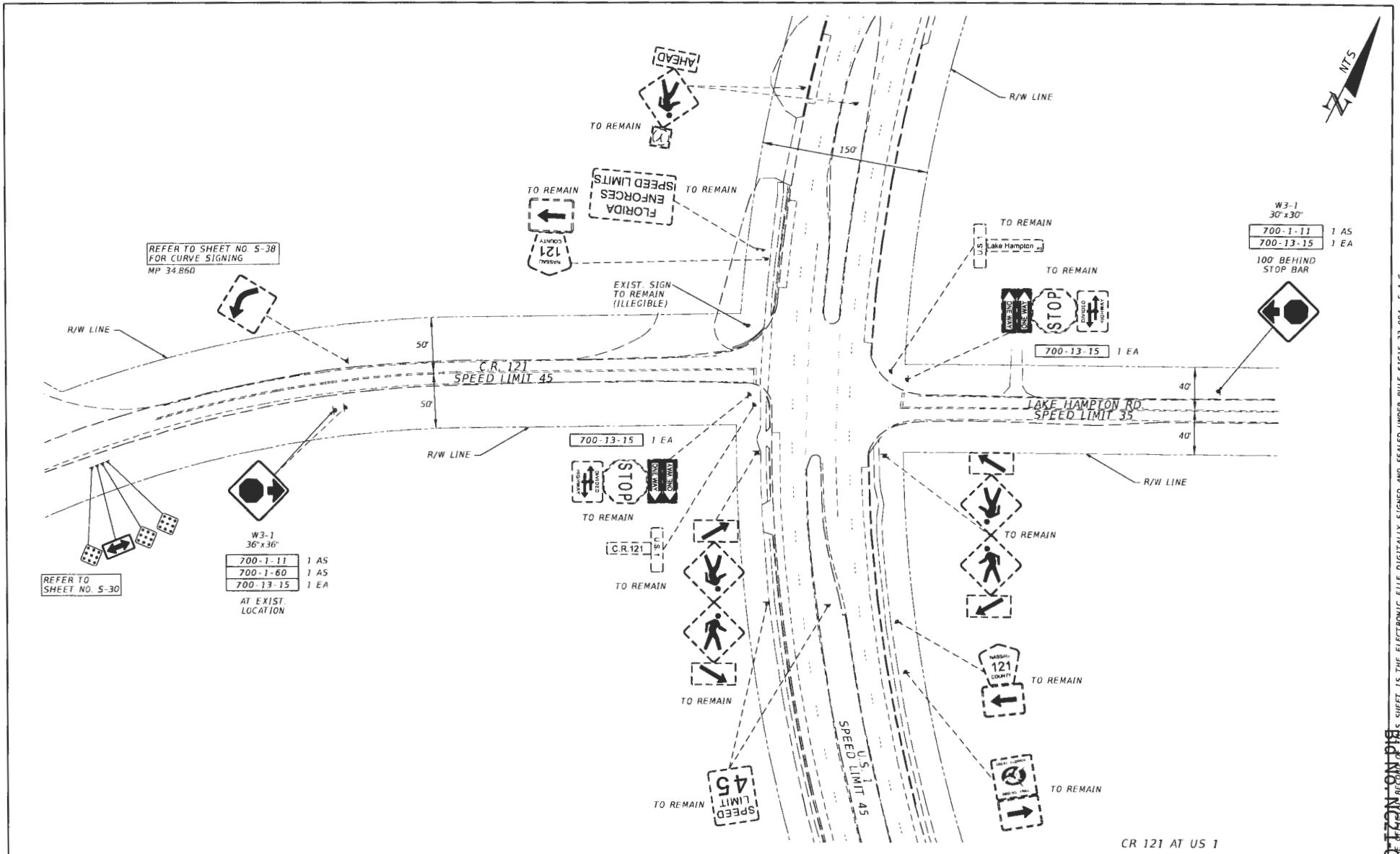

REFER TO SHEET NO. 5-3B
FOR CURVE SIGNING
MP 34.850

REFER TO SHEET NO. 5-30

W3-1
36"x36"
700-1-11 1 AS
700-1-60 1 AS
700-13-15 1 EA
AT EXIST.
LOCATION

W3-1
30"x30"
700-1-11 1 AS
700-13-15 1 EA
100' BEHIND
STOP BAR

CR 121 AT US 1

REVISIONS		DESCRIPTION	DATE	DESCRIPTION	DATE	DESCRIPTION
DATE	DESCRIPTION					

Ernest Lee Herbert IV, P.E.
P.E. License Number 79413
Comprehensive Engineering Services, Inc.
201 S Orange Ave, Suite 1300
Orlando, FL 32801-3442

STATE OF FLORIDA DEPARTMENT OF TRANSPORTATION		
ROAD NO.	COUNTY	FINANCIAL PROJECT ID
CR 121	NASSAU	441217-1-52-01

**SIGNING AND PAVEMENT
MARKING PLAN**

SHEET NO.
5-31

THIS SHEET IS THE ELECTRONIC FILE DIGITALLY SIGNED AND SEALED UNDER RULE 61G15-23.004, F.A.C.

Contract No. CM3150

BEGIN SIGNING AND PAVEMENT MARKINGS
MP 0.000

DUVAL COUNTY LINE

REMARK 6" WHITE

REMARK 6" WHITE

CR 121

HORSESHOE CIR. S
(D.I.C.)
MP 1.329

MATCH LINE "A"
(MP 2.500)

GENERAL NOTES:

- MILEPOSTS ARE APPROXIMATE
- REFER TO SHEET NO. S-39 FOR INTERSECTION PAVEMENT MARKING DETAIL
- REFER TO SHEET NOS. S-9 THROUGH S-31 FOR CENTERLINE STRIPING AT INTERSECTIONS
- R/W LINES SHOWN ARE FOR CURVE WARNING SIGN LOCATIONS. THE R/W LINES ARE NOT TO SCALE BUT INSTEAD HAVE BEEN DIMENSIONED FOR CLARITY. ADDITIONAL R/W INFORMATION AT INTERSECTIONS WHERE WORK IS TO BE PERFORMED CAN BE FOUND ON SHEET NOS. S-9 THROUGH S-31



MATCH LINE "A"
(MP 2.500)

REMARK 6" WHITE

REMARK 6" WHITE

HORSESHOE CIR.
(D.I.C.)
MP 3.572

MP 3.730
700-1-12 1 AS
700-1-60 1 AS
700-13-15 1 EA

W1-2R
48" X 48"

R/W LINE

50'

BRANDY BRANCH
CIRCULE PL.
MP 4.275

MP 4.584
700-1-12 1 AS
700-1-60 1 AS
700-13-15 1 EA

W1-2L
48" X 48"

R/W LINE

50'

BOYD RD. (D.I.C.)
MP 4.649

MATCH LINE "B"
(MP 5.000)

W1-2L
48" X 48"

700-1-12 1 AS
700-1-60 1 AS
700-13-15 1 EA

MP 3.348

R/W LINE

50'

W1-2R
48" X 48"

700-1-12 1 AS
700-1-60 1 AS
700-13-15 1 EA

MP 4.036

R/W LINE

50'

W1-2L
48" X 48"

700-1-12 1 AS
700-1-60 1 AS
700-13-15 1 EA

MP 4.884

R/W LINE

50'



REVISIONS			
DATE	DESCRIPTION	DATE	DESCRIPTION

Ernest Lee Herbert IV, P.E.
P.E. License Number 79413
Comprehensive Engineering Services, Inc.
201 S Orange Ave, Suite 1300
Orlando, FL 32801-3442

STATE OF FLORIDA DEPARTMENT OF TRANSPORTATION		
ROAD NO.	COUNTY	FINANCIAL PROJECT ID.
CR 121	NASSAU	441217-1-52-01

**SIGNING AND PAVEMENT
MARKING PLAN**

SHEET NO.
S-32

Contract No. CM3150
SHEET NO. S-32
THIS IS THE ELECTRONIC FILE DIGITALLY SIGNED AND SEALED UNDER RULE 61G15-23.004, F.A.C.

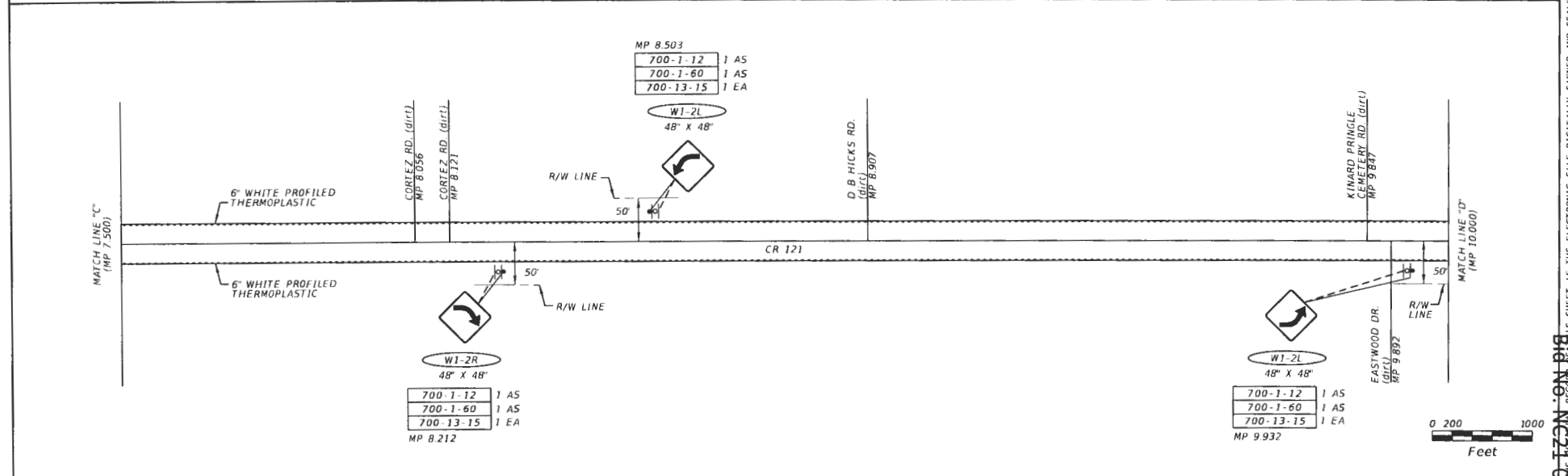
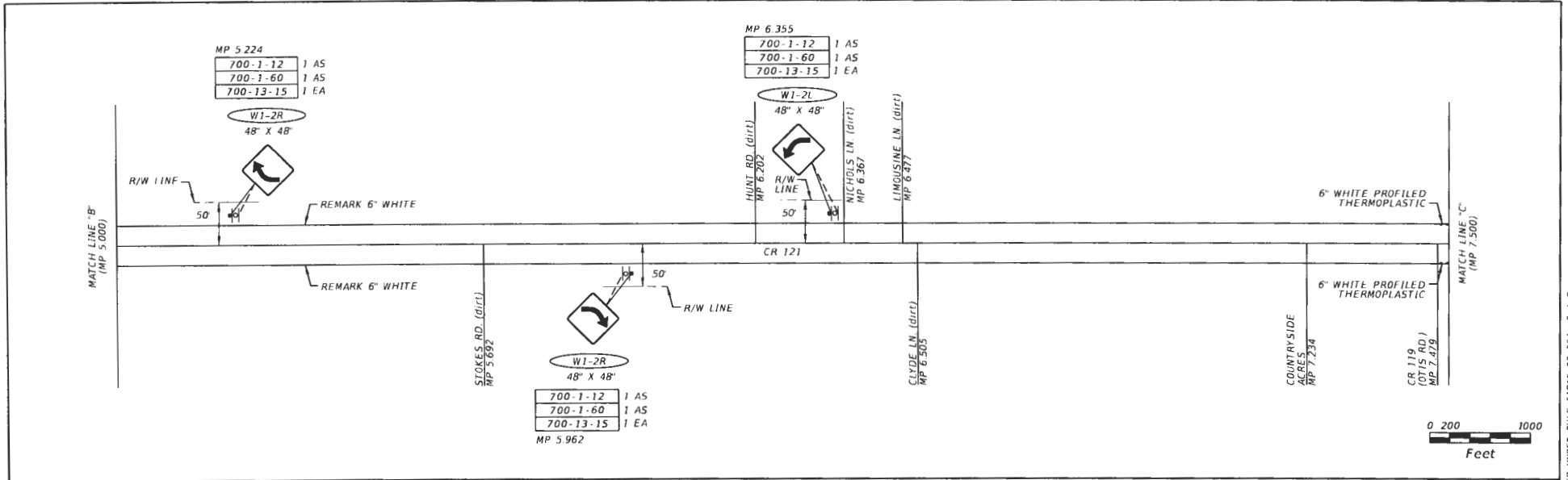

REVISIONS				Ernest Lee Herbert IV, P.E. P.E. License Number 79413 Comprehensive Engineering Services, Inc. 201 S Orange Ave, Suite 1300 Orlando, FL 32801-3442	STATE OF FLORIDA DEPARTMENT OF TRANSPORTATION			SIGNING AND PAVEMENT MARKING PLAN	SHEET NO. S-33
DATE	DESCRIPTION	DATE	DESCRIPTION		ROAD NO.	COUNTY	FINANCIAL PROJECT ID		
					CR 121	NASSAU	441217-1-52-01		

THIS SHEET IS THE ELECTRONIC FILE DIGITALLY SIGNED AND SEALED UNDER RULE 61G15-23.004, F.A.C.
 CONTRACT NO. CM3150
 SHEET NO. S-33 OF 34

Contract No. CM3150
 THIS SHEET IS THE ELECTRONIC FILE DIGITALLY SIGNED AND SEALED UNDER RULE 61G15-23.004, F.A.C.
 DATE RECORDED: 11/18/2021 10:41 AM

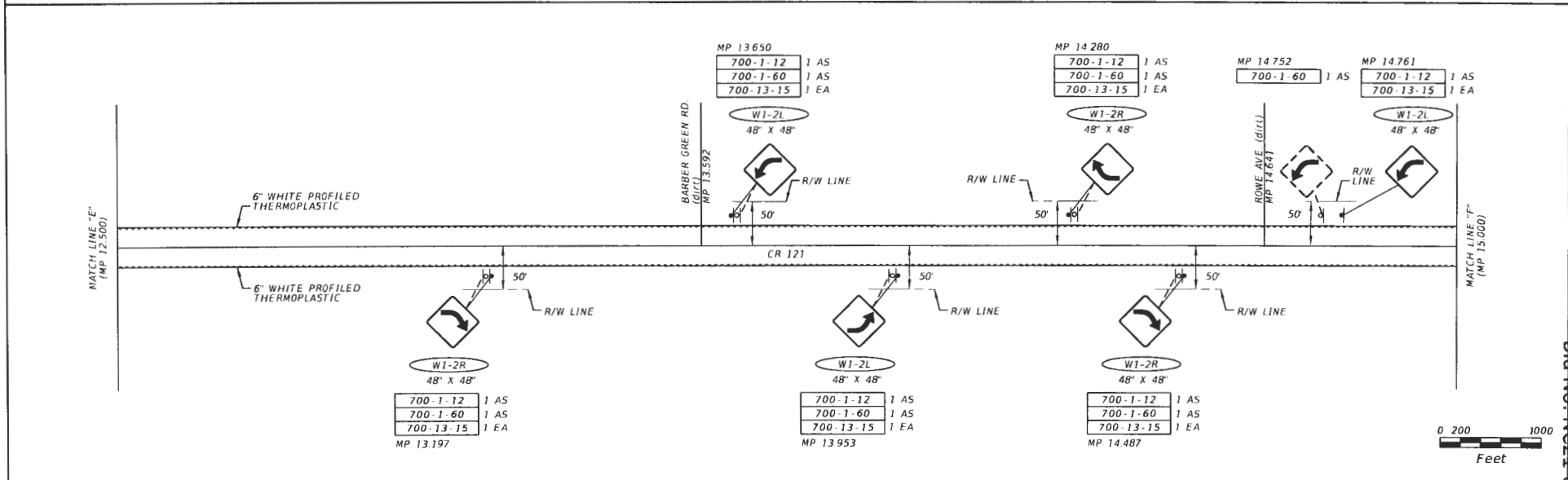
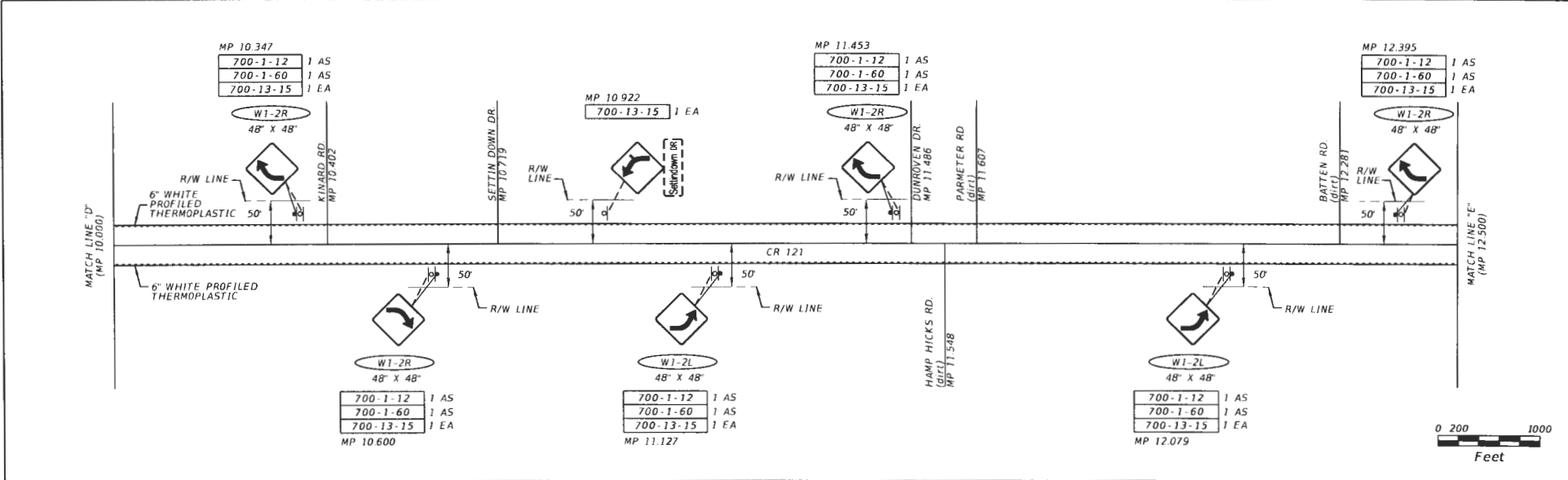

REVISIONS				Ernest Lee Herbert IV, P.E. P.E. License Number 79413 Comprehensive Engineering Services, Inc. 201 S Orange Ave, Suite 1300 Orlando, FL 32801-3442	STATE OF FLORIDA DEPARTMENT OF TRANSPORTATION			SIGNING AND PAVEMENT MARKING PLAN	SHEET NO. S-34
DATE	DESCRIPTION	DATE	DESCRIPTION		ROAD NO.	COUNTY	FINANCIAL PROJECT ID		
					CR 121	NASSAU	441217-1-52-01		

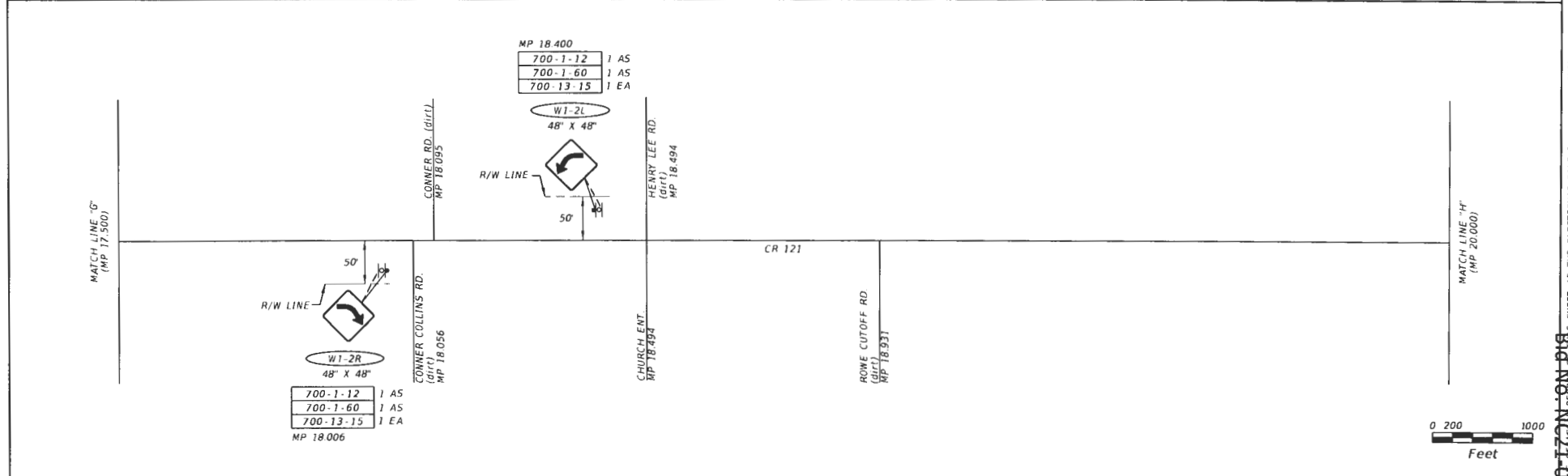
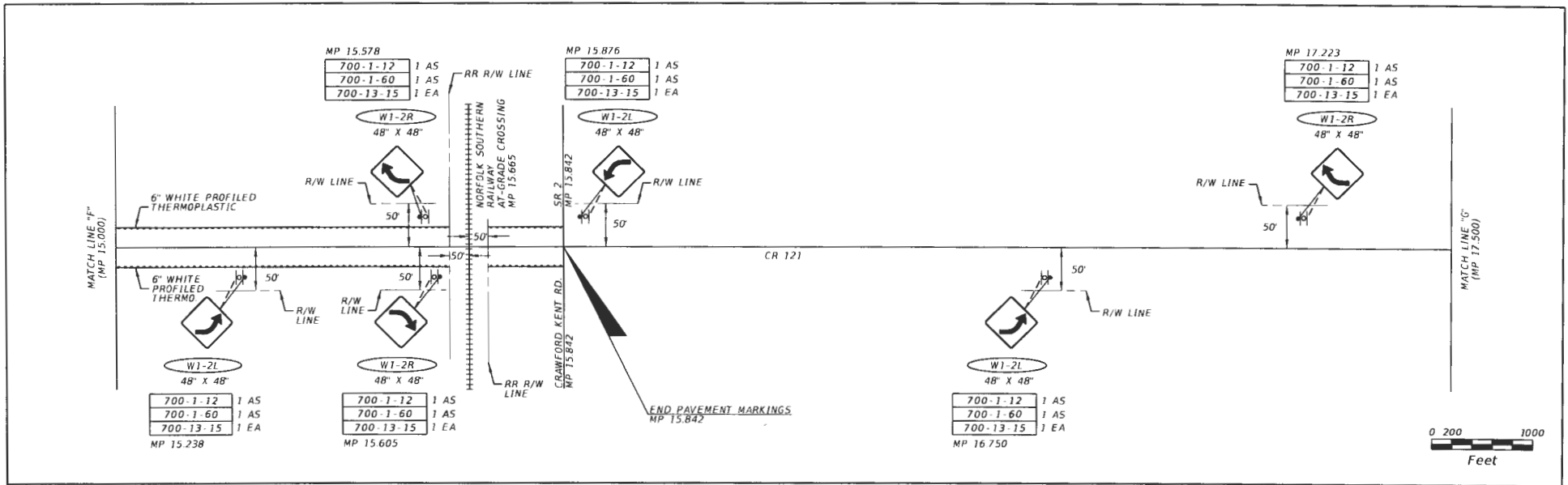

REVISIONS				Ernest Lee Herbert IV, P.E. P.E. License Number 79413 Comprehensive Engineering Services, Inc. 201 S Orange Ave, Suite 1300 Orlando, FL 32801-3442	STATE OF FLORIDA DEPARTMENT OF TRANSPORTATION			SIGNING AND PAVEMENT MARKING PLAN	SHEET NO. S-35
DATE	DESCRIPTION	DATE	DESCRIPTION		ROAD NO.	COUNTY	FINANCIAL PROJECT ID		
					CR 121	NASSAU	441217-1-52-01		

E:\herbert 11/18/2021 4:22:25 PM T:\Projects\1300807\44121715201\signing\plans\p27.dgn

CONTRACT NO. CM3150
 SHEET 15 THE ELECTRONIC FILE DIGITALLY SIGNED AND SEALED UNDER RULE 61G15-23.004, F.A.C.
 11/18/2021 4:22:25 PM

Contract No. CM3150
 THIS SHEET IS THE ELECTRONIC FILE DIGITALLY SIGNED AND SEALED UNDER RULE 61G15-23.004, F.A.C.
 11/18/2021 4:22:25 PM I:\Projects\1500807\44121715201\signing\plans\28.dgn

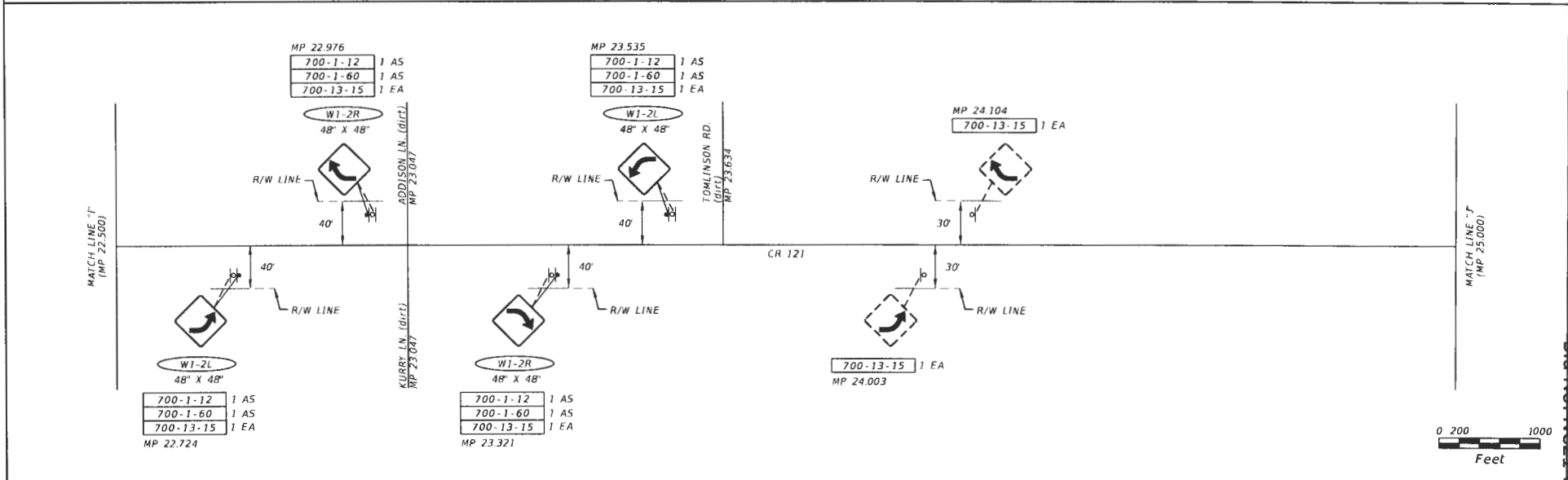
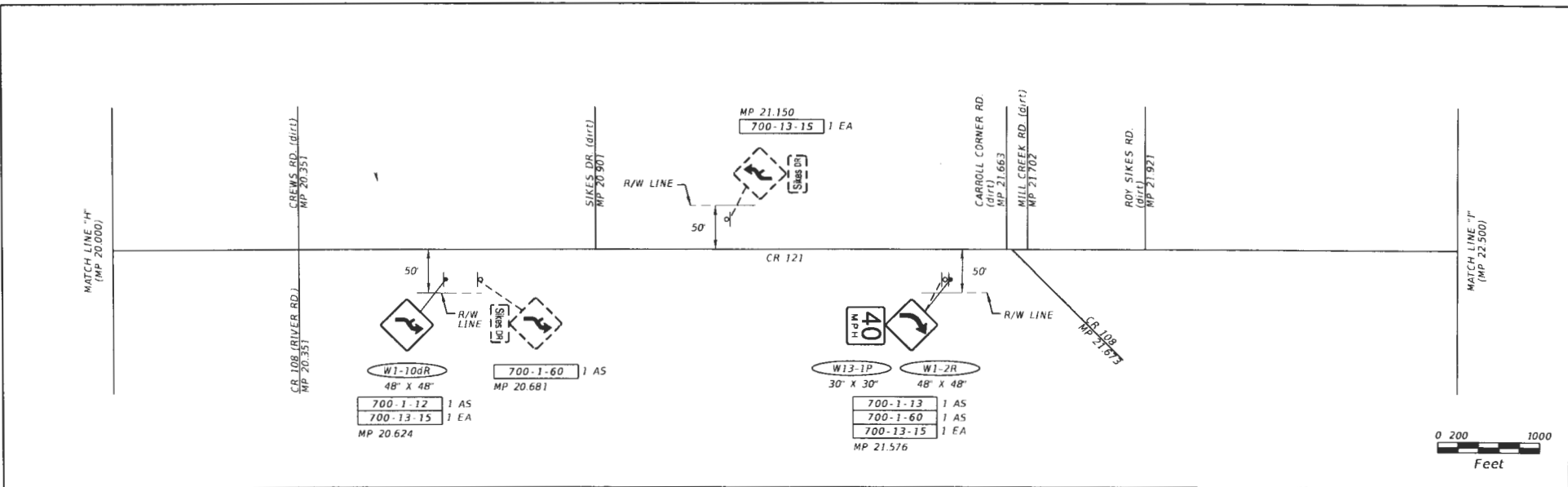

REVISIONS				Ernest Lee Herbert IV, P.E. P.E. License Number 79413 Comprehensive Engineering Services, Inc. 201 S Orange Ave, Suite 1300 Orlando, FL 32801-3442	STATE OF FLORIDA DEPARTMENT OF TRANSPORTATION			SIGNING AND PAVEMENT MARKING PLAN	SHEET NO. 5-36
DATE	DESCRIPTION	DATE	ROAD NO		COUNTY	FINANCIAL PROJECT ID			
			CR 121		NASSAU	441217-1-52-01			

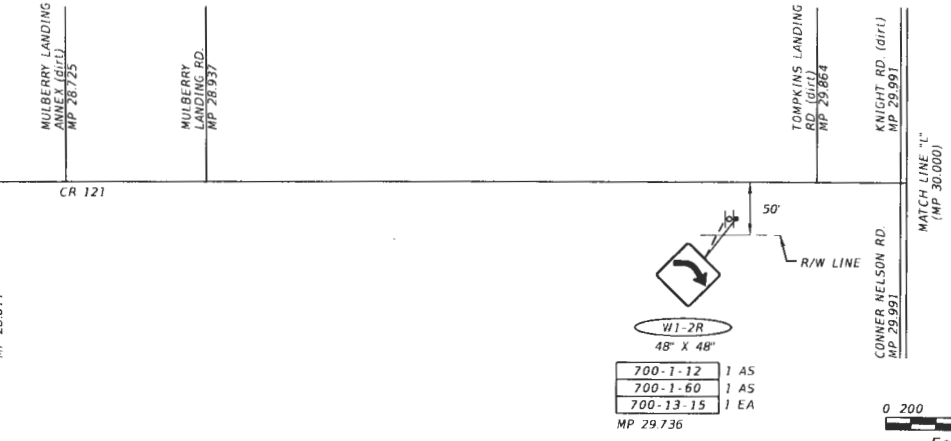
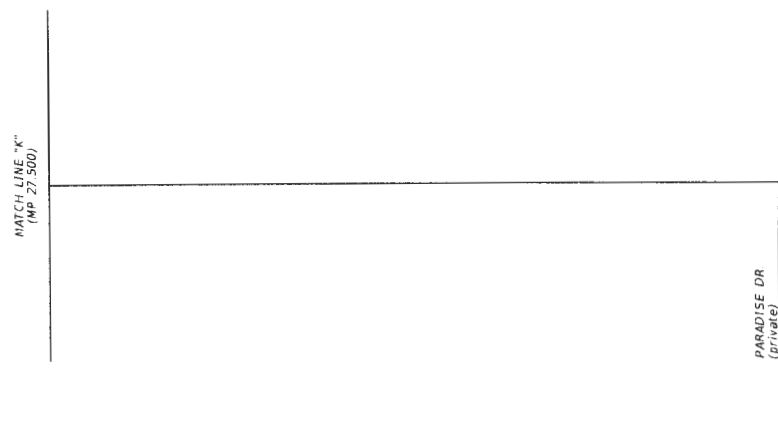
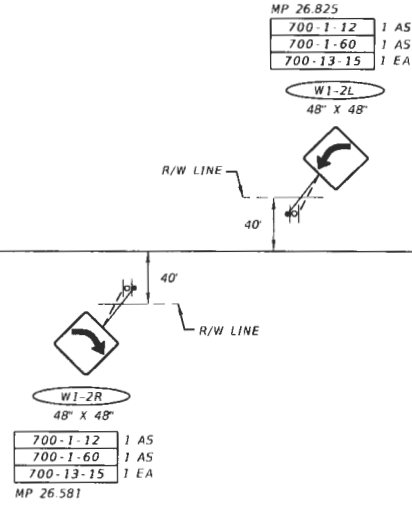
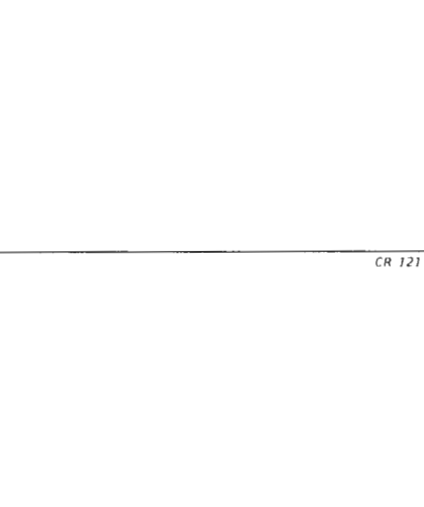
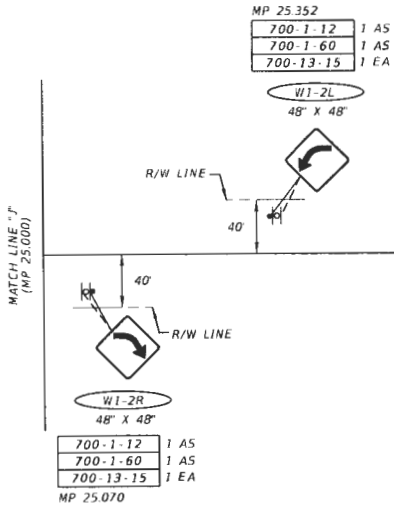

REVISIONS	
DATE	DESCRIPTION

Ernest Lee Herbert IV, P.E.
P.E. License Number 79413
Comprehensive Engineering Services, Inc.
201 S Orange Ave, Suite 1300
Orlando, FL 32801-3442

STATE OF FLORIDA DEPARTMENT OF TRANSPORTATION		
ROAD NO.	COUNTY	FINANCIAL PROJECT ID
CR 121	NASSAU	441217-1-52-01

**SIGNING AND PAVEMENT
MARKING PLAN**

SHEET NO.
S-37

THIS SHEET IS THE ELECTRONIC FILE DIGITALLY SIGNED AND SEALED UNDER RULE 61G15-23.004, F.A.C.

Contract No. CM3150

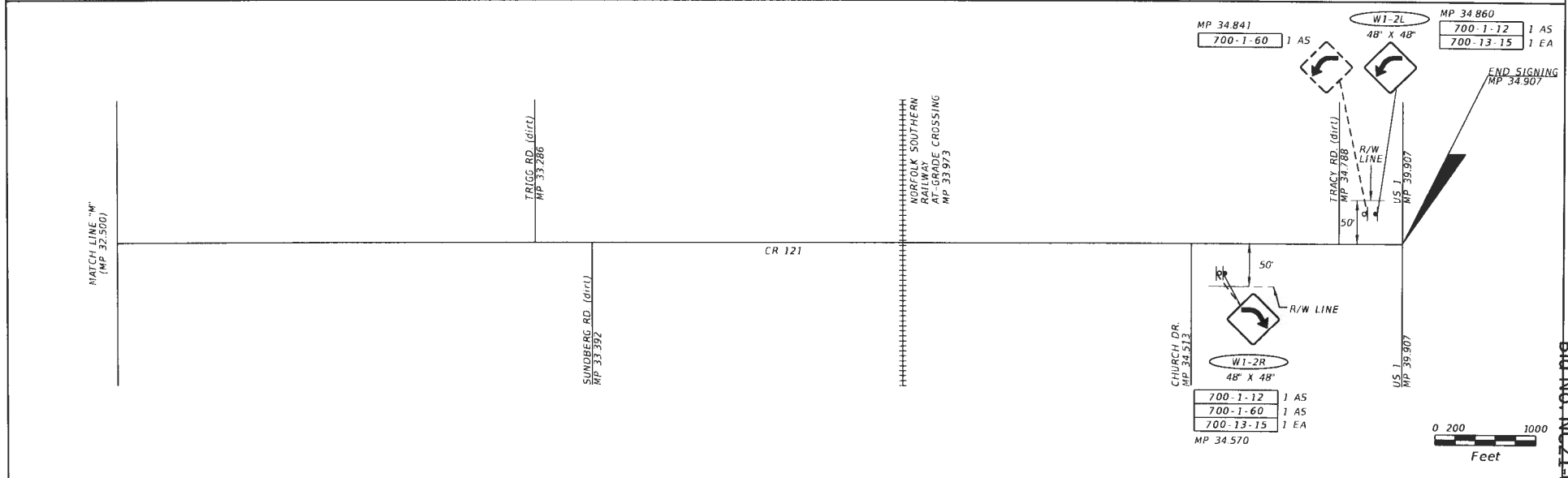
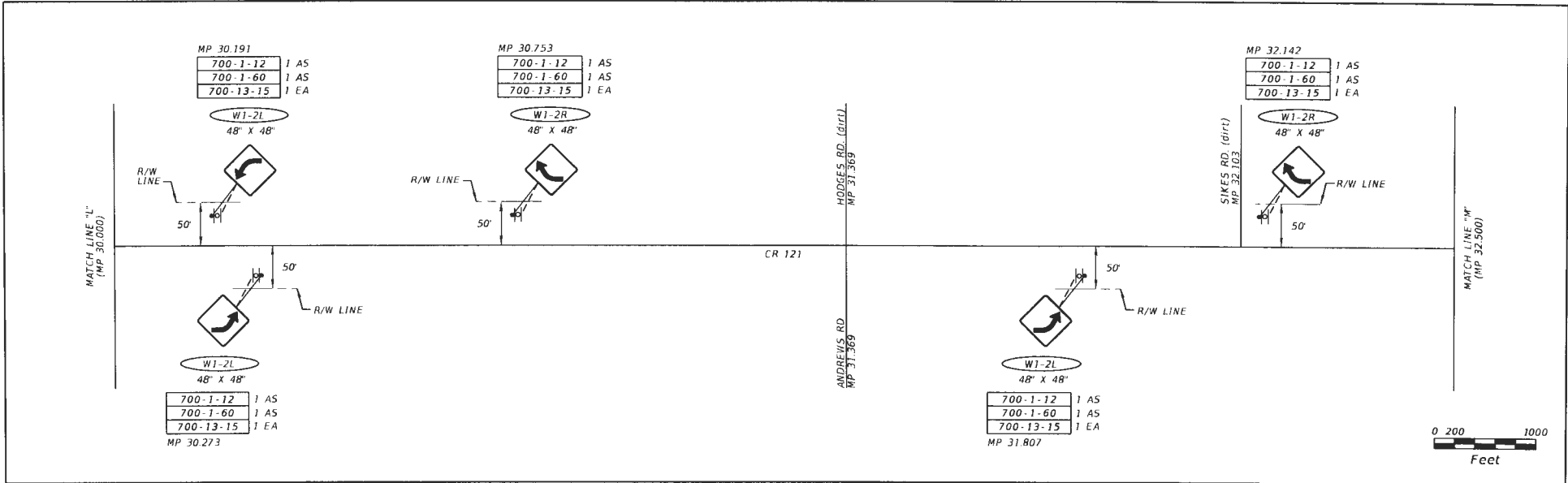

REVISIONS		DESCRIPTION	DATE	DESCRIPTION
DATE	DESCRIPTION			

Ernest Lee Herbert IV, P.E. P.E. License Number 79413 Comprehensive Engineering Services, Inc. 201 S Orange Ave, Suite 1300 Orlando, FL 32801-3442			STATE OF FLORIDA DEPARTMENT OF TRANSPORTATION		SIGNING AND PAVEMENT MARKING PLAN	SHEET NO. S-38
ROAD NO.	COUNTY	FINANCIAL PROJECT ID	CR 121 NASSAU 441217-1-52-01			

EHerbert 11/18/2021 4:22:26 PM I:\Projects\151500807\44121715201\signing\plansp41.dgn

CONTRACT NO. CM3150
 SHEET NO. S-38
 THIS SHEET IS THE ELECTRONIC FILE DIGITALLY SIGNED AND SEALED UNDER RULE 61G15-23.004, F.A.C.

INTERSECTION PAVEMENT MARKING DETAIL (TYP.)

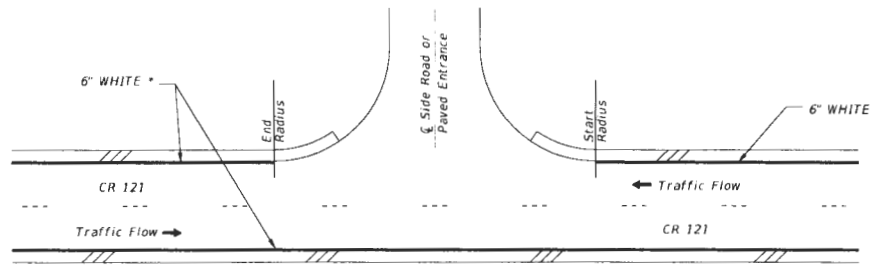

* 6" WHITE PAINT FROM MP 0.000 TO MP 7.479;
 6" WHITE PROFILED THERMOPLASTIC FROM MP 7.479 TO MP 15.842

REVISIONS				Ernest Lee Herbert IV, P.E. P.E. License Number 79413 Comprehensive Engineering Services, Inc. 201 S Orange Ave, Suite 1300 Orlando, FL 32801-3442	STATE OF FLORIDA DEPARTMENT OF TRANSPORTATION			SHEET NO. S-39
DATE	DESCRIPTION	DATE	DESCRIPTION		ROAD NO.	COUNTY	FINANCIAL PROJECT ID	
					CR 121	NASSAU	441217-1-52-01	

6/Herbert

11/18/2021

4:22:27 PM

T:\Projects\1500807\441217\15201\signing\plansp42.dgn

THIS SHEET IS THE ELECTRONIC FILE DIGITALLY SIGNED AND SEALED UNDER RULE 61G15-23.004, F.A.C.
 CONTRACT NO. CM3150
 SHEET NO. S-39

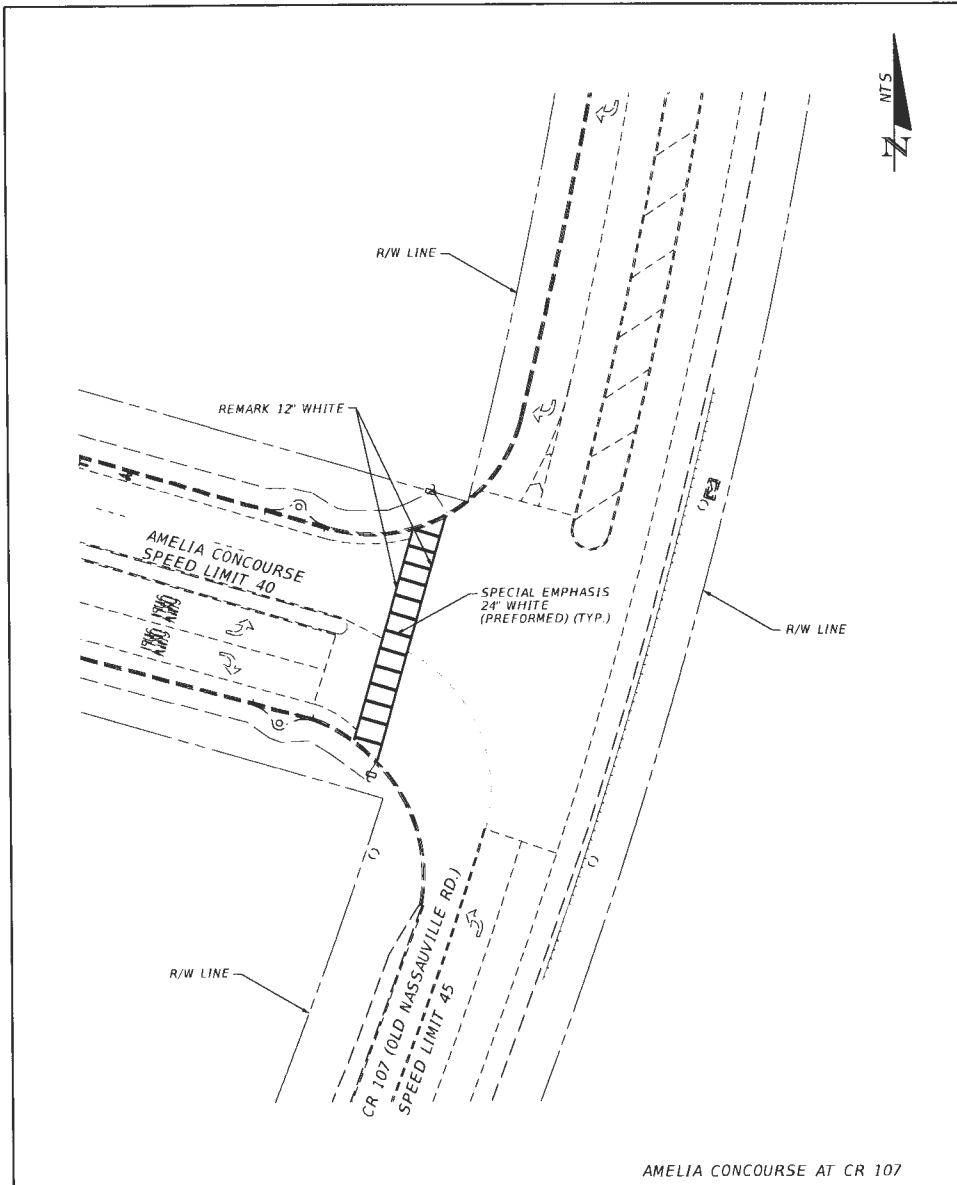

AMELIA CONCOURSE AT CR 107

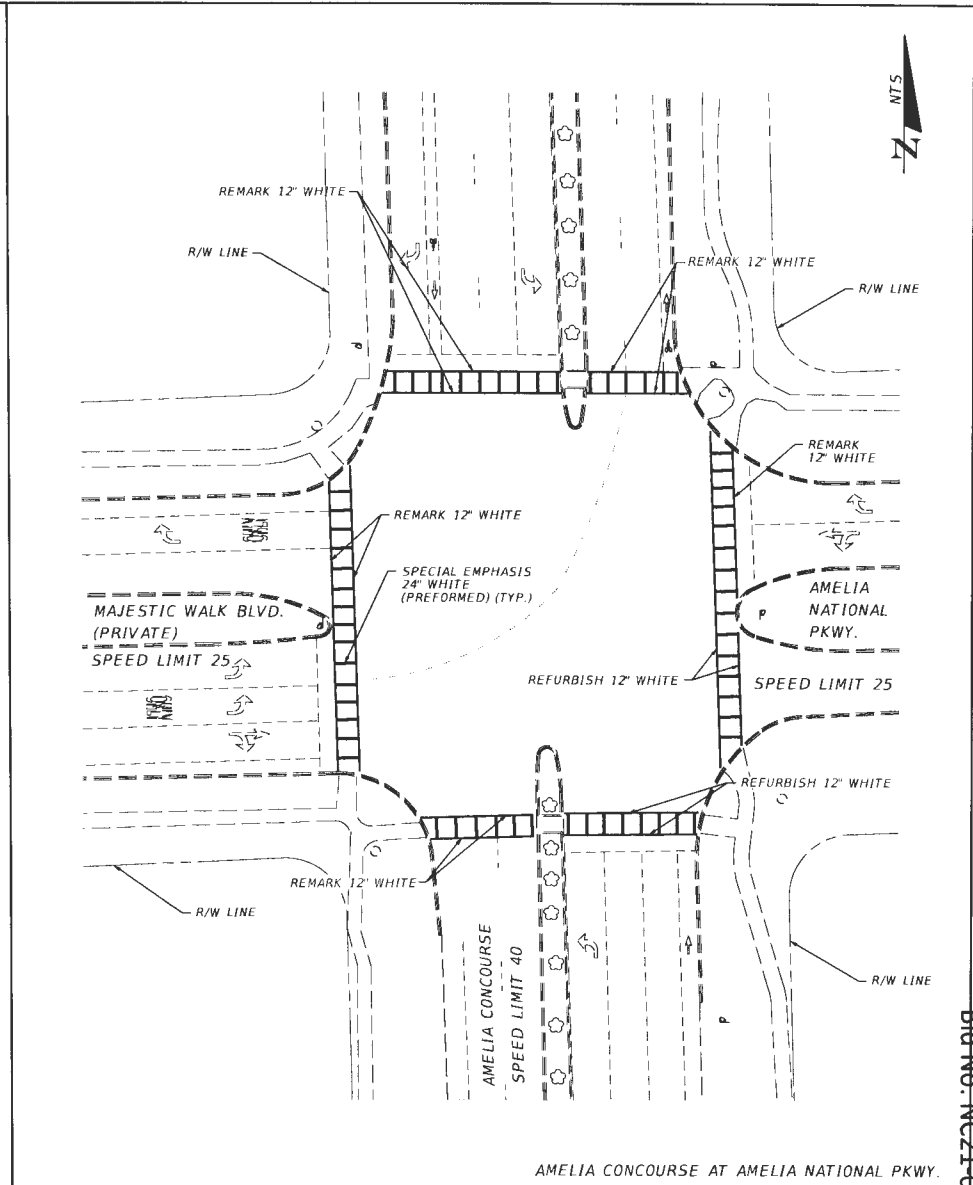

AMELIA CONCOURSE AT AMELIA NATIONAL PKWY.

REVISIONS	
DATE	DESCRIPTION

Ernest Lee Herber IV, P.E.
P.E. License Number 79413
Comprehensive Engineering Services, Inc.
201 S Orange Ave, Suite 1300
Orlando, FL 32801-3442

STATE OF FLORIDA DEPARTMENT OF TRANSPORTATION		
ROAD NO.	COUNTY	FINANCIAL PROJECT ID
N/A	NASSAU	441217-1-52-01

**SIGNING AND PAVEMENT
MARKING PLAN**

SHEET NO.
S-40

THIS SHEET IS THE ELECTRONIC FILE DIGITALLY SIGNED AND SEALED UNDER RULE 61G15-23.004, F.A.C.
 PROJECT RECORD NO. NC21-014

Contract No. CM3150

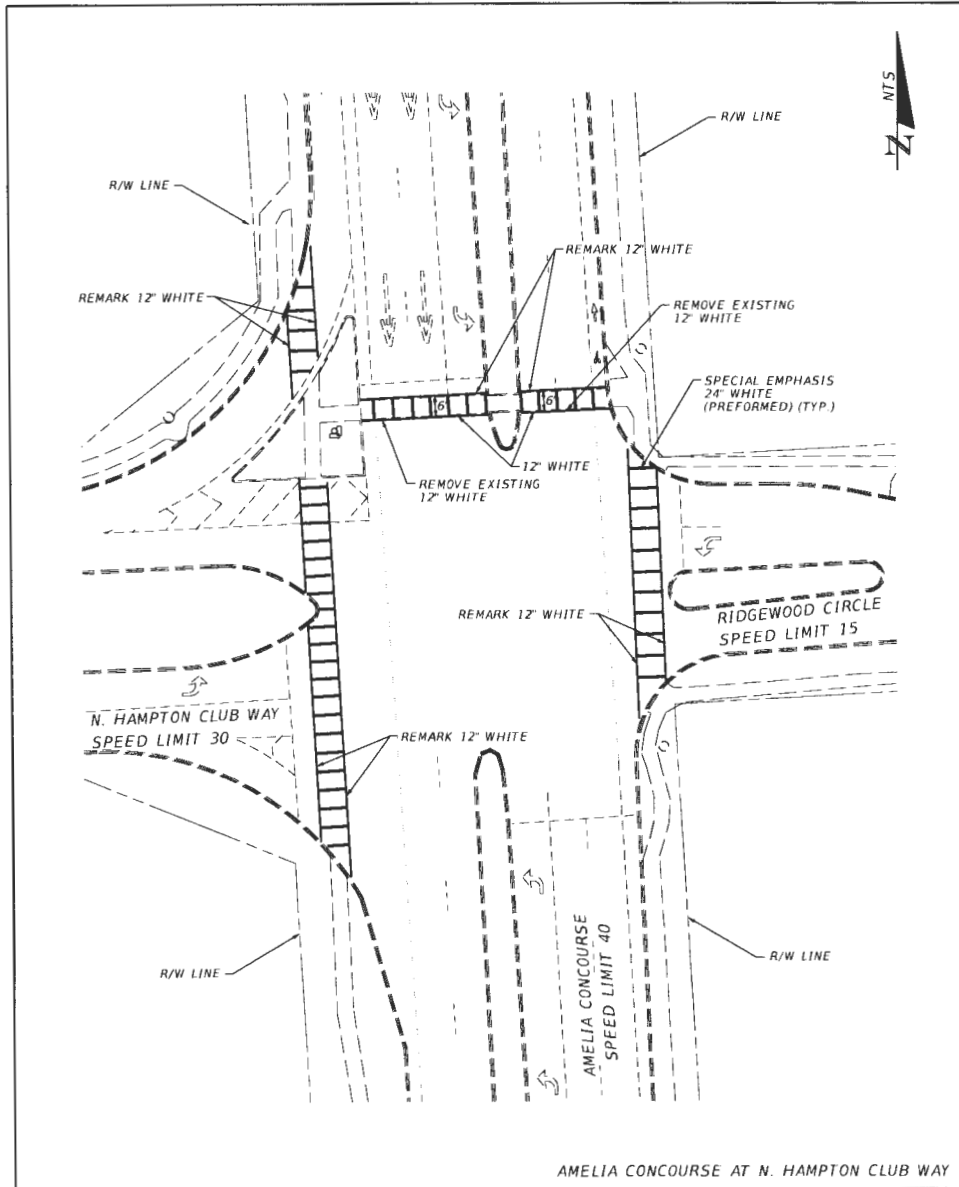

AMELIA CONCOURSE AT N. HAMPTON CLUB WAY

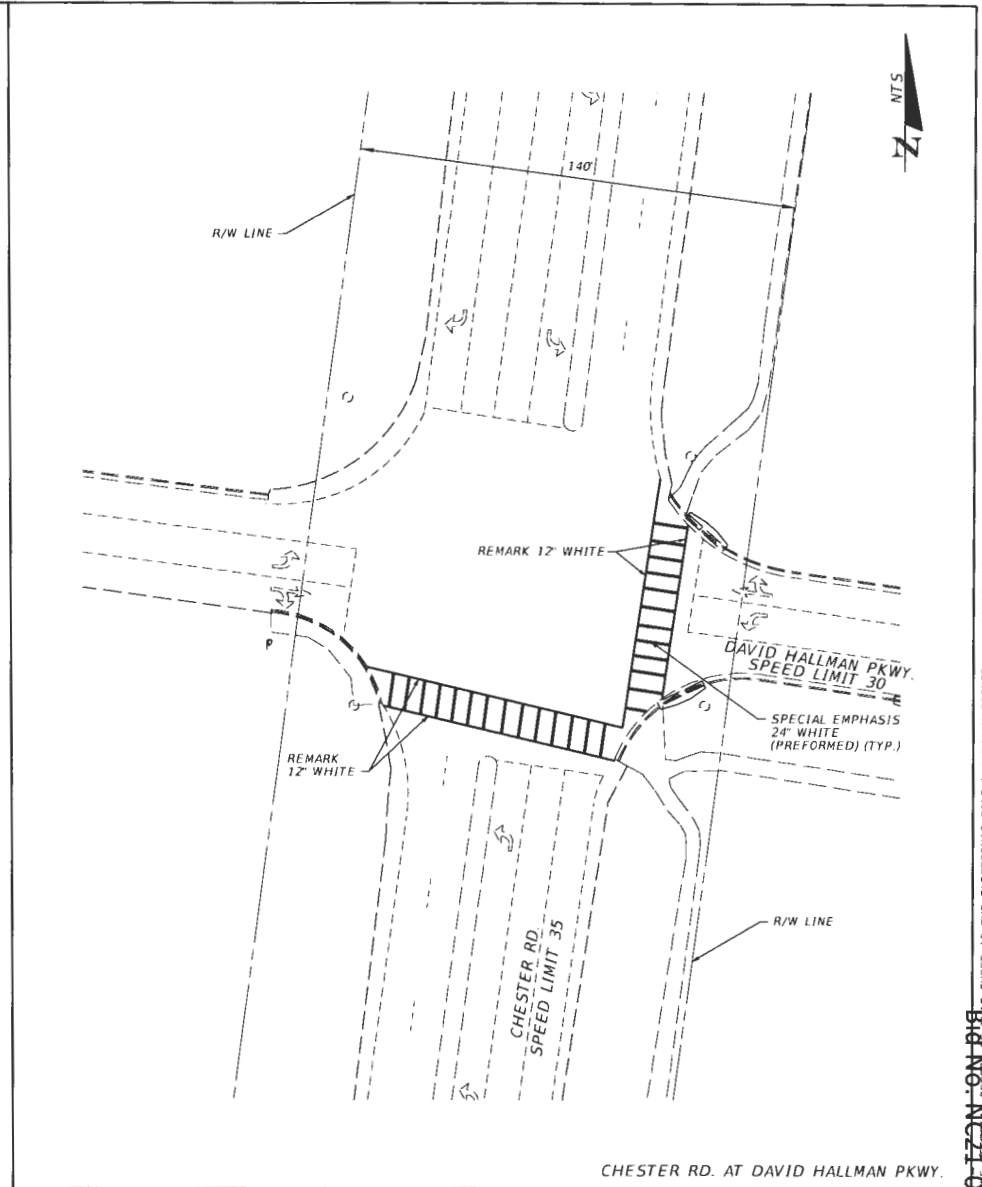

CHESTER RD. AT DAVID HALLMAN PKWY.

REVISIONS			
DATE	DESCRIPTION	DATE	DESCRIPTION

Ernest Lee Herbert IV, P.E.
P.E. License Number 79413
Comprehensive Engineering Services, Inc.
201 S Orange Ave, Suite 1300
Orlando, FL 32801-3442

STATE OF FLORIDA DEPARTMENT OF TRANSPORTATION		
ROAD NO.	COUNTY	FINANCIAL PROJECT ID
N/A	NASSAU	441217-1-52-01

**SIGNING AND PAVEMENT
MARKING PLAN**

SHEET NO.
5-41

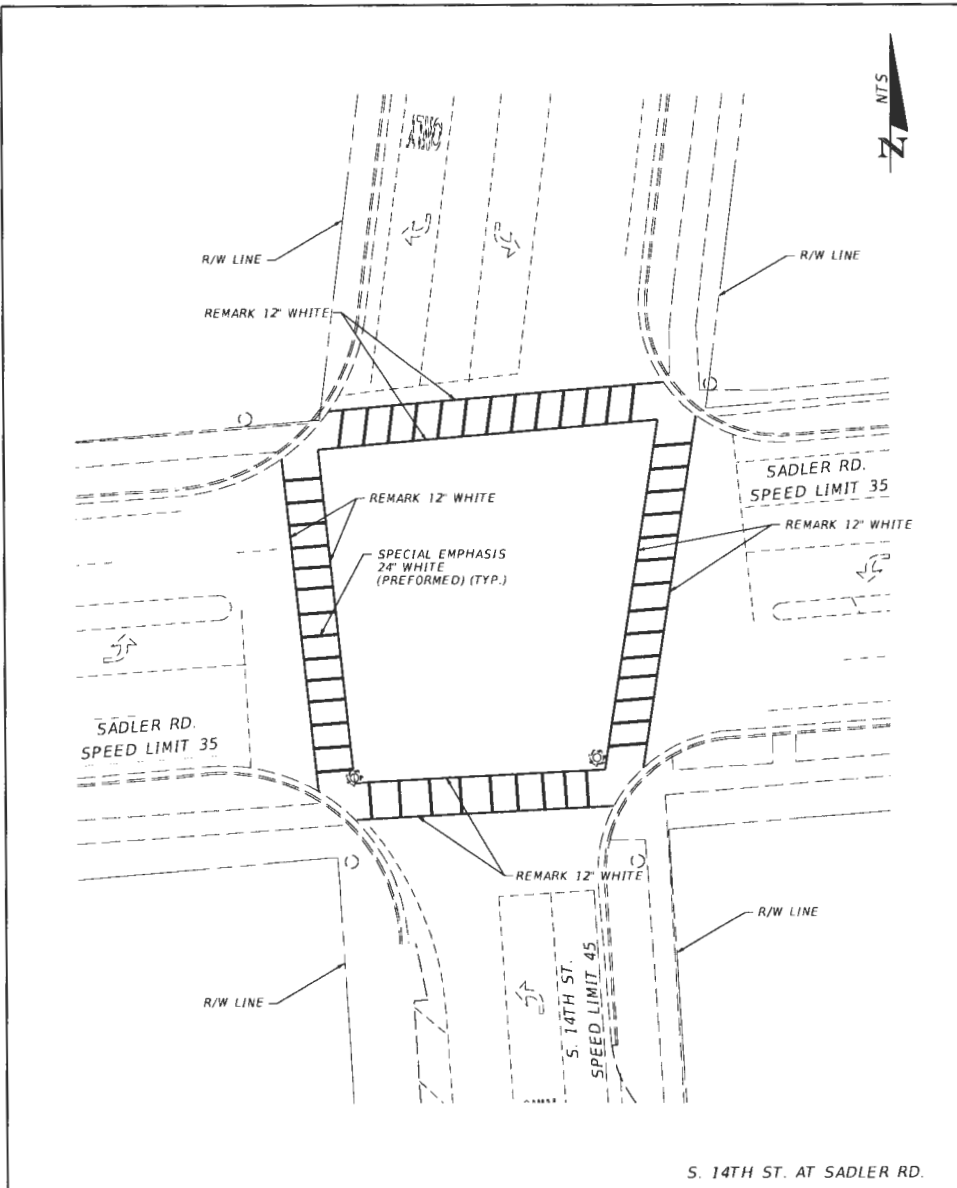

S. 14TH ST. AT SADLER RD.

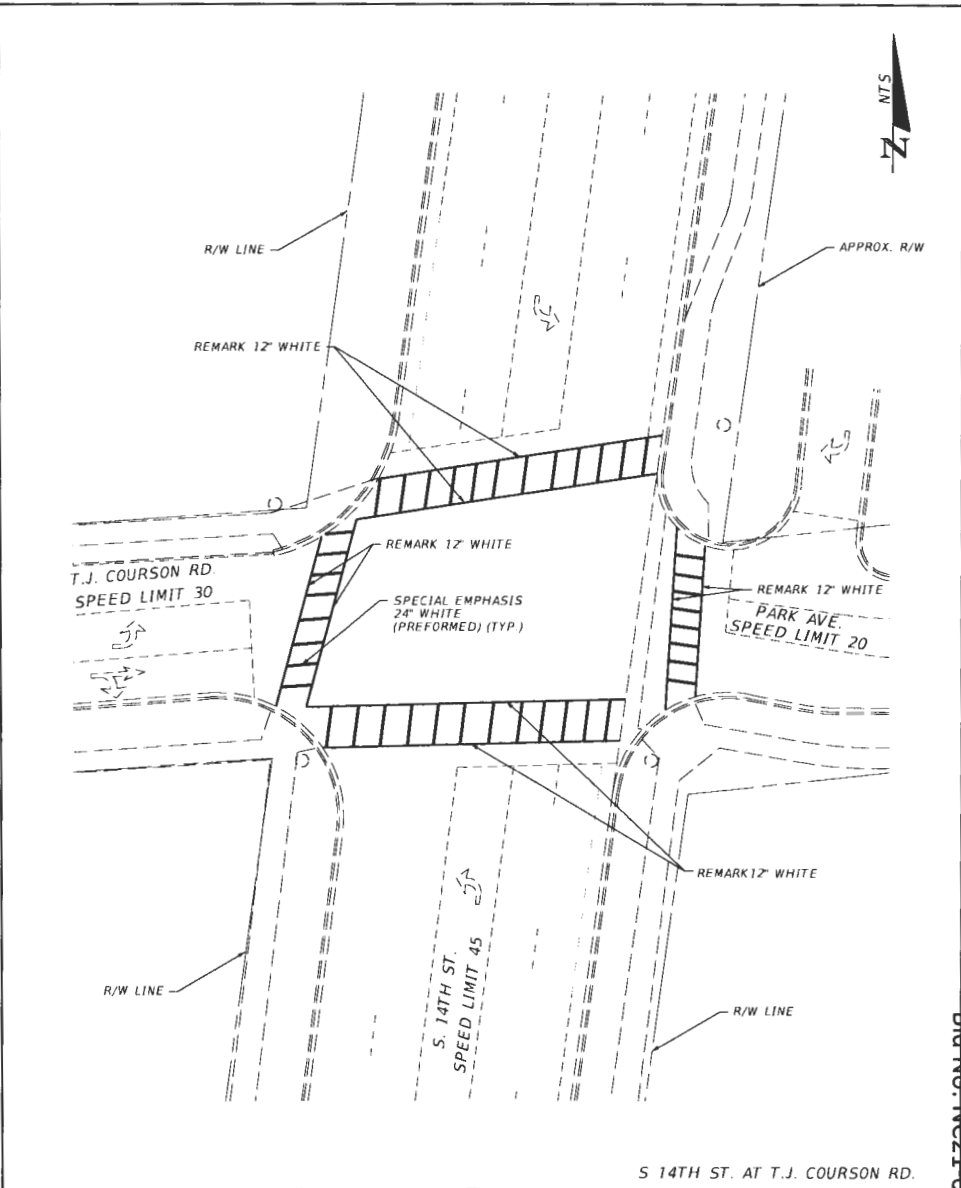

S. 14TH ST. AT T.J. COURSON RD.

REVISIONS			
DATE	DESCRIPTION	DATE	DESCRIPTION

Ernest Lee Herbert IV, P.E.
P.E. License Number 79413
Comprehensive Engineering Services, Inc.
201 S Orange Ave, Suite 1300
Orlando, FL 32801-3442

STATE OF FLORIDA DEPARTMENT OF TRANSPORTATION		
ROAD NO.	COUNTY	FINANCIAL PROJECT ID
CR 105A	NASSAU	441217-1-52-01

**SIGNING AND PAVEMENT
MARKING PLAN**

SHEET NO.
S-42

THE OFFICIAL RECORD OF THIS SHEET IS THE ELECTRONIC FILE DIGITALLY SIGNED AND SEALED UNDER RULE 61G15-22.009, F.A.C.

Contract No. CM3150
 BIRG No. NCS21-014

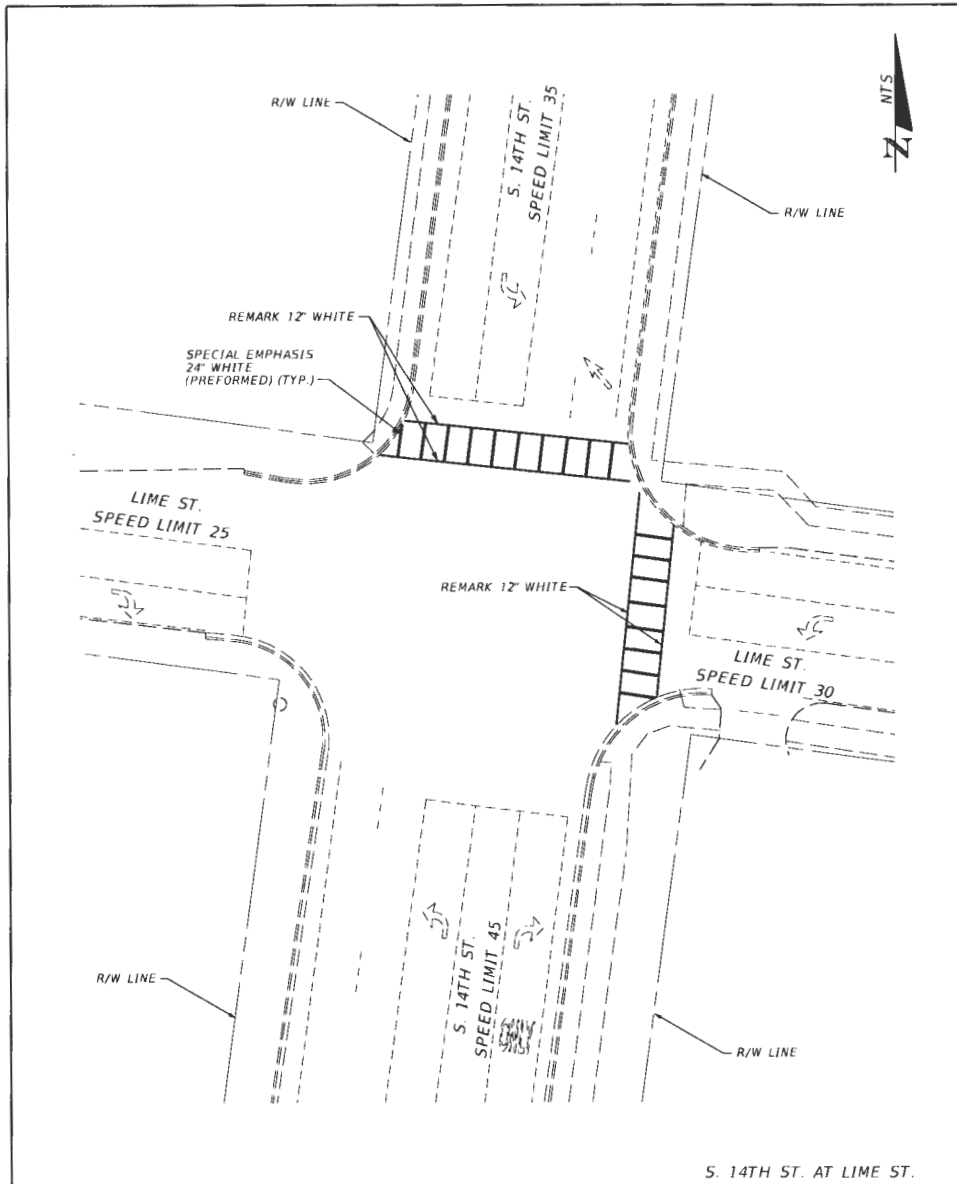

S. 14TH ST. AT LIME ST.

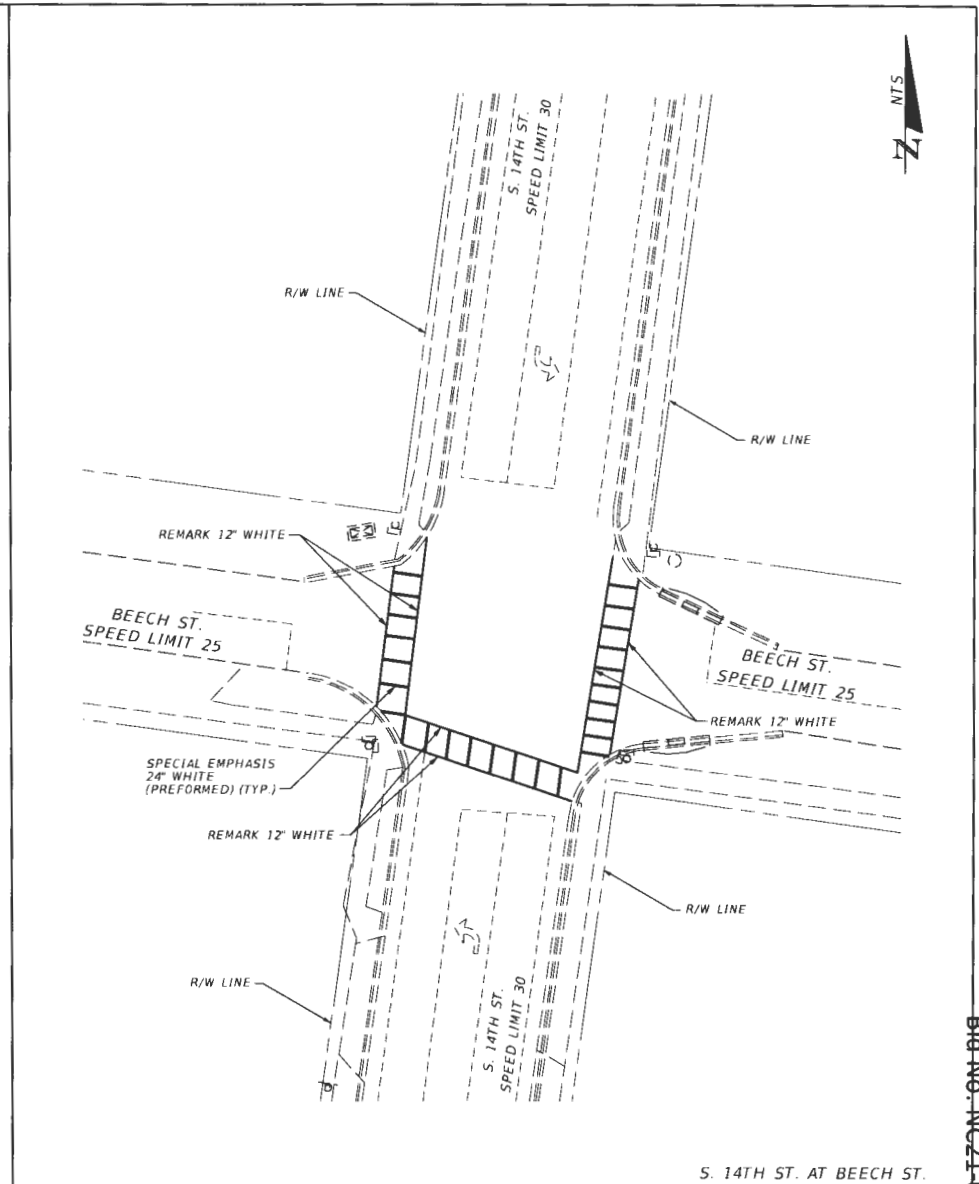

S. 14TH ST. AT BEECH ST.

REVISIONS			
DATE	DESCRIPTION	DATE	DESCRIPTION

Ernest Leo Herbert IV, P.E.
 P.E. License Number 79413
 Comprehensive Engineering Services, Inc.
 201 S Orange Ave, Suite 1300
 Orlando, FL 32801-3442

STATE OF FLORIDA DEPARTMENT OF TRANSPORTATION		
ROAD NO.	COUNTY	FINANCIAL PROJECT ID
CR 105A	NASSAU	441217-1-52-01

**SIGNING AND PAVEMENT
MARKING PLAN**

SHEET NO.
S-43

THIS SHEET IS THE ELECTRONIC FILE DIGITALLY SIGNED AND SEALED UNDER RULE 61G15-23.004, F.A.C.
 PROJECT NO. 441217-1-52-01

Contract No. CM3150

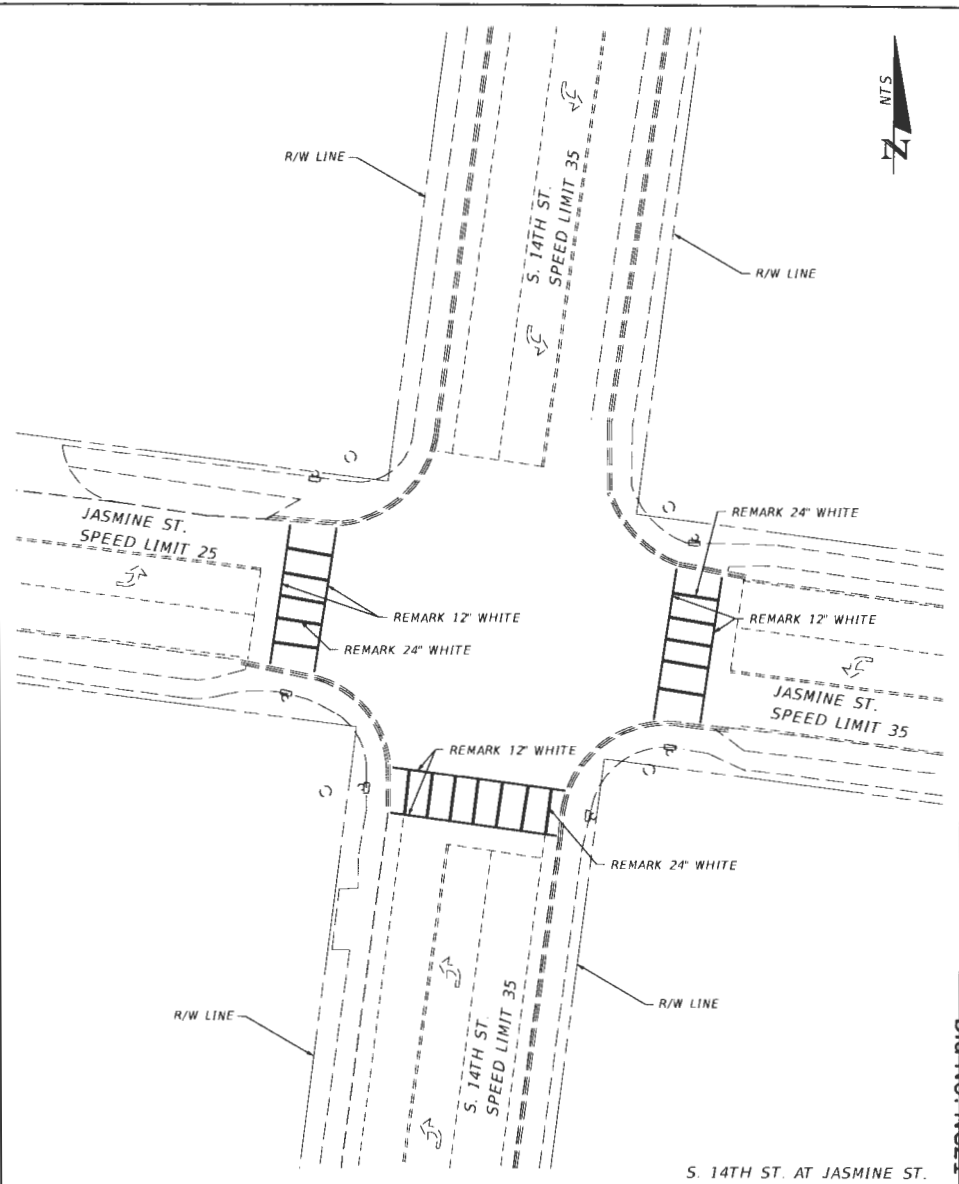
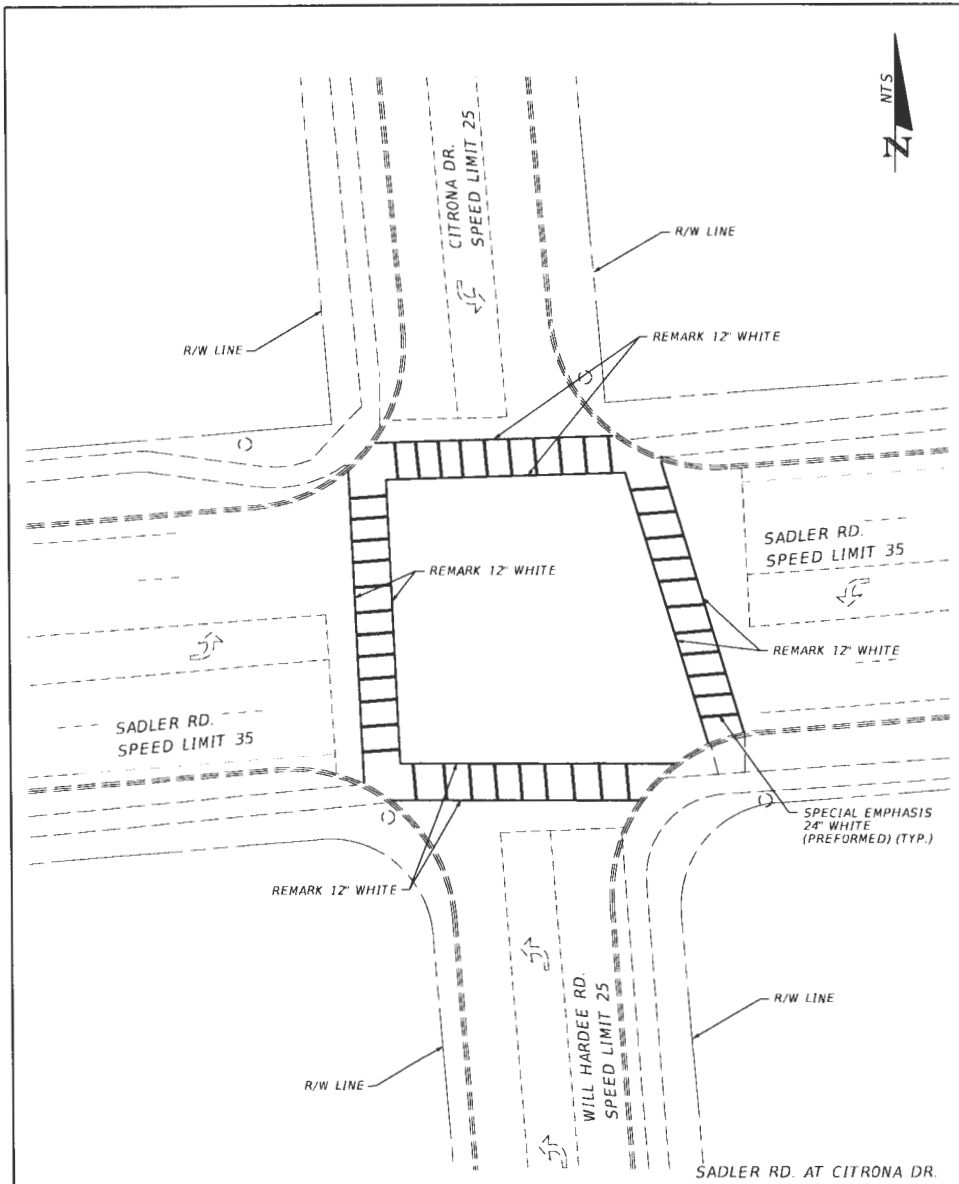

REVISIONS			
DATE	DESCRIPTION	DATE	DESCRIPTION

Ernest Lee Herbert IV, P.E.
P.E. License Number 79413
Comprehensive Engineering Services, Inc.
201 S Orange Ave, Suite 1300
Orlando, FL 32801-3442

STATE OF FLORIDA DEPARTMENT OF TRANSPORTATION		
ROAD NO.	COUNTY	FINANCIAL PROJECT ID
CR 108	NASSAU	441217-1-52-01

**SIGNING AND PAVEMENT
MARKING PLAN**

SHEET NO.
S-44

eHerbert

11/18/2021

4:22:31 PM

T:\Projects\1509807\441217\15201\Signing\plans\2223.dgn

THIS SHEET IS THE ELECTRONIC FILE DIGITALLY SIGNED AND SEALED UNDER RULE 61G15-23.004, F.A.C.

Contract No. CM3150

TRAFFIC CONTROL NOTES

- TRAFFIC CONTROL SHALL CONFORM TO FDOT STANDARD PLAN INDEXES 102-602, 102-603, 102-604, 102-605, 102-615 & 102-660
- THE POSTED SPEED LIMITS SHALL REMAIN AT ALL TIMES DURING CONSTRUCTION.
THE POSTED SPEED FOR EACH ROADWAY IS AS FOLLOWS:

ROADWAY	SPEED LIMIT (MPH)
CR 121	55
AMELIA CONCOURSE	40
S. 14TH STREET	30/35/45
SADLER ROAD	35
CHESTER ROAD	35
- LANE CLOSURE RESTRICTIONS ARE AS FOLLOWS:
S. 14TH STREET & SADLER ROAD INTERSECTION: LANE CLOSURES ARE NOT PERMITTED FROM 11:00 AM TO 6:30 PM
A LANE MAY BE CLOSED DURING ACTIVE WORK PERIODS ONLY
- UTILIZE PORTABLE CHANGEABLE MESSAGE SIGNS (PCMS) DURING ACTIVE DAYTIME AND NIGHTTIME OPERATIONS.
- PORTABLE CHANGEABLE MESSAGE SIGNS HAVE BEEN INCLUDED IN THE CONTRACT TO PROVIDE INFORMATION TO MOTORISTS DURING THE MAINTENANCE OF TRAFFIC PHASES. LOCATIONS OF THE SIGNS, ALONG WITH CONTENT AND LENGTH OF MESSAGE ARE TO BE APPROVED BY THE ENGINEER.
- ADJUST ALL ROADWAY SIGNS AS NECESSARY DURING THE PLACEMENT OF ALL WORK ZONE SIGNING.

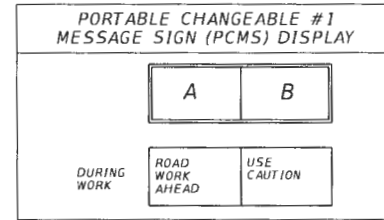

TYPICAL ADVANCED SIGNING DETAIL

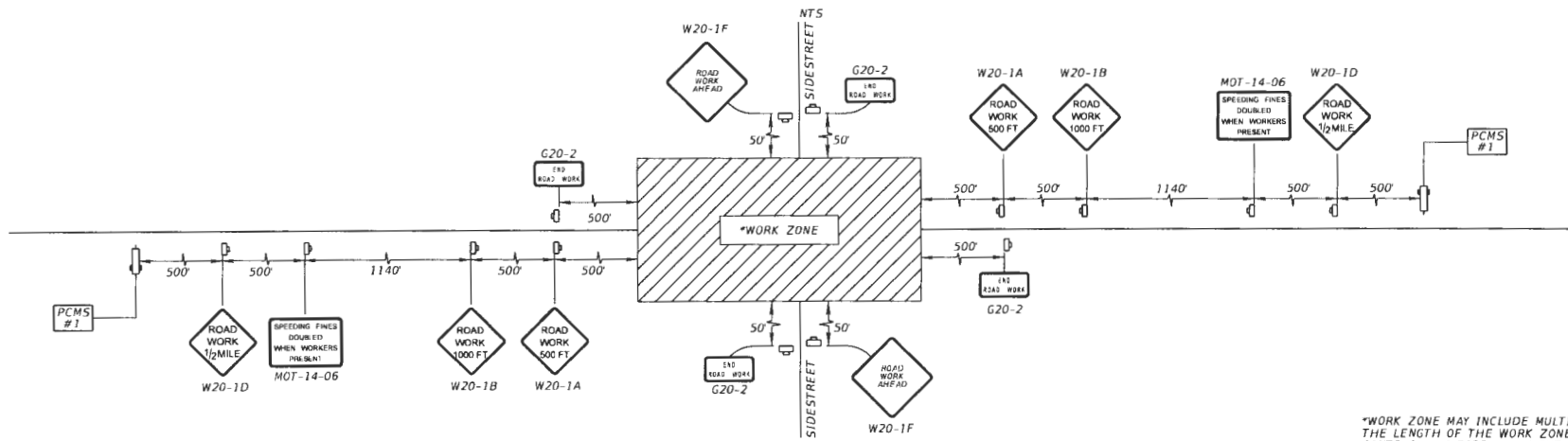

*WORK ZONE MAY INCLUDE MULTIPLE SIDESTREETS
THE LENGTH OF THE WORK ZONE IS AT THE CONTRACTOR'S DISCRETION BUT SHOULD BE LIMITED TO ACTIVE WORK AREAS.

REVISIONS				Ernest Lee Herbert IV, P.E. P.E. License Number 79413 Comprehensive Engineering Services, Inc. 201 S Orange Ave, Suite 1300 Orlando, FL 32801-3442	STATE OF FLORIDA DEPARTMENT OF TRANSPORTATION			TEMPORARY TRAFFIC CONTROL PLAN	SHEET NO.
DATE	DESCRIPTION	DATE	DESCRIPTION		ROAD NO.	COUNTY	FINANCIAL PROJECT ID		S-45
					N/A	NASSAU	441217-1-52-01		

E. APPENDICES

**APPENDIX A -
FDOT FORMS & CONDITIONS**

Section 00 45 40
LAP FORMS

- LAP Certification of Current Capacity
- Bid Opportunity List for Commodities & Contractual Services
- Non-Collusion Declaration and Compliance Form
- Certification Regarding Debarment, Suspension, Ineligibility and Voluntary Exclusion
- Certification for Disclosure of Lobbying Activities
- DBE Bid Package Information

[Remainder of page intentionally left blank.]

NASSAU COUNTY INVITATION TO BID

NC21-014-ITB - CR-121, S. 14TH ST., CHESTER RD., SADLER RD., & AMELIA CONCOURSE

For bids to be received on _____
(Letting Date)

Fill in your FDOT Vendor Number VF _____ (Only applicable to FDOT pre-qualified contractors)
--

CERTIFICATE

I hereby certify that the amount of any proposal submitted by this bidder for the above letting does not exceed the amount of the Firm's CURRENT CAPACITY (maximum capacity rating less total uncompleted work).

The total uncompleted work as shown on
the "Status of Contracts on Hand" report (page 2) \$ _____

I further certify that the "Status of Contracts on Hand" report (page 2) was prepared as follows:

1. If the letting is before the 25th day of the month, the certificate and report reflect the uncompleted work as of the 15th day of the month, last preceding the month of the letting.
2. If the letting is after the 25th day of the month, the certificate and report reflects the uncompleted work in progress as of the 15th day of the month of the letting.
3. All new contracts (and subcontracts) awarded earlier than five days before the letting date are included in the report and charged against our total rating.

I certify that the information above is correct.

NAME OF FIRM

Sworn to and subscribed this _____ day
of _____, 20 _____

By: _____

Title

NASSAU COUNTY INVITATION TO BID
 NC21-014-ITB - CR-121, S. 14TH ST., CHESTER RD., SADLER RD., & AMELIA CONCOURSE

(Furnish complete information about all your contracts, whether prime or subcontracts;
 whether in progress or awarded, but not yet begun; and regardless of whom contracted with.)

1	2	3	4	5		6
PROJECTS OWNER, LOCATION AND DESCRIPTION	CONTRACT (OR SUBCONTRACT) AMOUNT	AMOUNT SUBLET TO OTHERS	BALANCE OF CONTRACT AMOUNT	UNCOMPLETED AMOUNT TO BE DONE BY YOU		
				AS PRIME CONTRACTOR	AS SUBCONTRACTOR	
NOTE: Columns 2 and 3 to show total contract (or subcontract) amounts. Column 4 to be difference between columns 2 and 3. Amount in columns 5 or 6 to be uncompleted portion of amount in column 4. All amounts to be shown to nearest \$100. The Contractor may consolidate and list as a single item all contracts which, individually, do not exceed 3% of total, and which, in the aggregate, amount to less than 20% of the total.			TOTALS	\$0.00	\$0.00	
			TOTAL UNCOMPLETED WORK ON HAND TO BE DONE BY YOU (TOTAL COLUMNS 5 AND 6)		\$0.00	

Contract No. CM3150
 Bid No. NC21-014

DBE Utilization

The Department began its DBE race neutral program January 1, 2000. **Contract specific goals are not placed on Federal/State contracts;** however, the Department has an overall 10.65% DBE goal it must achieve. In order to assist contractors in determining their DBE commitment level, the Department has reviewed the estimates for this letting.

As you prepare your bid, please monitor potential or anticipated DBE utilization for contracts. When the low bidder executes the contract with the Department, information will be requested of the contractor's DBE participation for the project. While the utilization is not mandatory in order to be awarded the project, continuing utilization of DBE firms on contracts supports the success of Florida's DBE Program, and supports contractors' Equal Employment Opportunity and DBE Affirmative Action Programs.

Any project listed as 0% DBE availability does not mean that a DBE may not be used on that project. A 0% DBE availability may have been established due to any of the following reasons: limited identified subcontracting opportunities, minimal contract days, and/or small contract dollar amount. Contractors are encouraged to identify any opportunities to subcontract to DBE's.

Please contact the Equal Opportunity Office at (850) 414-4747 if you have any questions regarding this information.

DBE Reporting

If you are the prime contractor on a project, enter your DBE participation in the Equal Opportunity Compliance system prior to the pre-construction or pre-work conference for all federal and state funded projects. This **will not** become a mandatory part of the contract. It will assist the Department in tracking and reporting planned or estimated DBE utilization. During the contract, the prime contractor is required to report actual payments to DBE and MBE subcontractors through the web-based Equal Opportunity Compliance (EOC) system.

All DBE payments must be reported whether or not you initially planned to utilize the company. In order for our race neutral DBE Program to be successful, your cooperation is imperative. If you have any questions, please contact EOOHelp@dot.state.fl.us.

Bid Opportunity List

The Federal DBE Program requires States to maintain a database of all firms that are participating or attempting to participate on FDOT-assisted contracts. The list must include all firms that bid on prime contracts or bid or quote subcontracts on FDOT-assisted projects, including both **DBE's and non-DBEs**.

Please complete the Bidders Opportunity List through the Equal Opportunity Compliance system within 3 business days of submission of the bid or proposal for ALL subcontractors or sub-consultants who quoted to you for specific project for this letting. The web address to the Equal Opportunity Compliance system is: <https://www.fdot.gov/equalopportunity/eoc.shtm>.

STATE OF FLORIDA DEPARTMENT OF TRANSPORTATION
CERTIFICATION FOR DISCLOSURE OF LOBBYING ACTIVITIES
ON FEDERAL AID CONTRACTS
(Compliance with 49CFR, Section 20.100 (b))
375-030-33

The prospective participant certifies, by signing this certification, that to the best of his or her knowledge and belief:

(1) No federal appropriated funds have been paid or will be paid, by or on behalf of the undersigned, to any person for influencing or attempting to influence an officer or employee of any federal agency, a Member of Congress, an officer or employee of Congress, or an employee of a Member of Congress in connection with the awarding of any federal contract, the making of any federal grant, the making of any federal loan, the entering into of any cooperative agreement, and the extension, continuation, renewal, amendment, or modification of any federal contract, grant, loan, or cooperative agreement.

(2) If any funds other than federal appropriated funds have been paid or will be paid to any person for influencing or attempting to influence an officer or employee of any federal agency, a Member of Congress, an officer or employee of Congress, or an employee of a Member of Congress in connection with this federal contract, grant, loan, or cooperative agreement, the undersigned shall complete and submit Standard Form-LLL, "Disclosure of Lobbying Activities", in accordance with its instructions. (Standard Form-LLL can be obtained from the Florida Department of Transportation's Professional Services Administrator or Procurement Office.)

This certification is a material representation of fact upon which reliance was placed when this transaction was made or entered into. Submission of this certification is a prerequisite for making or entering into this transaction imposed by Section 1352, Title 31, U.S. Code. Any person who fails to file the required certification shall be subject to a civil penalty of not less than \$10,000 and not more than \$100,000 for each such failure.

The prospective participant also agrees by submitting his or her proposal that he or she shall require that the language of this certification be included in all lower tier subcontracts, which exceed \$100,000 and that all such subrecipients shall certify and disclose accordingly.

Name of Consultant: _____

By: _____ Date: _____

Authorized Signature: _____

Title: _____

STATE OF FLORIDA DEPARTMENT OF TRANSPORTATION
DISCLOSURE OF LOBBYING ACTIVITIES

375-030-34
 PROCUREMENT
 02/16

Is this form applicable to your firm?

YES NO

If no, then please complete section 4 below for "Prime"

1. Type of Federal Action: a. contract b. grant c. cooperative agreement d. loan e. loan guarantee f. loan insurance	2. Status of Federal Action: a. bid/offer/application b. initial award c. post-award	3. Report Type: a. initial filing b. material change For Material Change Only: Year: _____ Quarter: _____ Date of last report: _____ (mm/dd/yyyy)
4. Name and Address of Reporting Entity: <input type="checkbox"/> Prime <input type="checkbox"/> Subawardee Tier _____, if known: _____ _____ _____ Congressional District, if known: 4c _____		5. If Reporting Entity in No. 4 is a Subawardee, Enter Name and Address of Prime: _____ _____ _____ Congressional District, if known: _____
6. Federal Department/Agency: _____ _____	7. Federal Program Name/Description: _____ _____ CFDA Number, if applicable: _____	
8. Federal Action Number, if known: _____	9. Award Amount, if known: \$ _____	
10. a. Name and Address of Lobbying Registrant (if individual, last name, first name, MI): _____ _____ _____	b. Individuals Performing Services (including address if different from No. 10a) (last name, first name, MI): _____ _____ _____	
11. Information requested through this form is authorized by title 31 U.S.C. section 1352. This disclosure of lobbying activities is a material representation of fact upon which reliance was placed by the tier above when this transaction was made or entered into. This disclosure is required pursuant to 31 U.S.C. 1352. This information will be available for public inspection. Any person who fails to file the required disclosure shall be subject to a civil penalty of not less than \$10,000 and not more than \$100,000 for each such failure.	Signature: _____ Print Name: _____ Title: _____ Telephone No.: _____ Date (mm/dd/yyyy): _____	
Federal Use Only:		Authorized for Local Reproduction Standard Form LLL (Rev. 7-97)

INSTRUCTIONS FOR COMPLETION OF SF-LLL, DISCLOSURE OF LOBBYING ACTIVITIES

This disclosure form shall be completed by the reporting entity, whether subawardee or prime Federal recipient, at the initiation or receipt of a covered Federal action, or a material change to a previous filing, pursuant to title 31 U.S.C. section 1352. The filing of a form is required for each payment or agreement to make payment to any lobbying entity for influencing or attempting to influence an officer or employee of any agency, a Member of Congress, an officer or employee of Congress, or an employee of a Member of Congress in connection with a covered Federal action. Complete all items that apply for both the initial filing and material change report. Refer to the implementing guidance published by the Office of Management and Budget for additional information.

1. Identify the type of covered Federal action for which lobbying activity is and/or has been secured to influence the outcome of a covered Federal action.
2. Identify the status of the covered Federal action.
3. Identify the appropriate classification of this report. If this is a followup report caused by a material change to the information previously reported, enter the year and quarter in which the change occurred. Enter the date of the last previously submitted report by this reporting entity for this covered Federal action.
4. Enter the fullname, address, city, State and zip code of the reporting entity. Include Congressional District, if known. Check the appropriate classification of the reporting entity that designates if it is, or expects to be, a prime or subaward recipient. Identify the tier of the subawardee, e.g., the first subawardee of the prime is the 1st tier. Subawards include but are not limited to subcontracts, subgrants and contract awards under grants.
5. If the organization filing the report in item 4 checks "Subawardee," then enter the full name, address, city, State and zip code of the prime Federal recipient. Include Congressional District, if known.
6. Enter the name of the Federal agency making the award or loan commitment. Include at least one organizational level below agency name, if known. For example, Department of Transportation, United States Coast Guard.
7. Enter the Federal program name or description for the covered Federal action (item 1). If known, enter the full Catalog of Federal Domestic Assistance (CFDA) number for grants, cooperative agreements, loans, and loan commitments.
8. Enter the most appropriate Federal identifying number available for the Federal action identified in item 1 (e.g., Request for Proposal (RFP) number; Invitation for Bid (IFB) number; grant announcement number; the contract, grant, or loan award number; the application/proposal control number assigned by the Federal agency). Include prefixes, e.g., "RFP-DE-90-001."
9. For a covered Federal action where there has been an award or loan commitment by the Federal agency, enter the Federal amount of the award/loan commitment for the prime entity identified in item 4 or 5.
10. (a) Enter the full name, address, city, State and zip code of the lobbying registrant under the Lobbying Disclosure Act of 1995 engaged by the reporting entity identified in item 4 to influence the covered Federal action.

(b) Enter the full names of the individual(s) performing services, and include full address if different from 10 (a). Enter Last Name, First Name, and Middle Initial (MI).
11. The certifying official shall sign and date the form, print his/her name, title, and telephone number.

According to the Paperwork Reduction Act, as amended, no persons are required to respond to a collection of information unless it displays a valid OMB Control Number. The valid OMB control number for this information collection is OMB No. 0348-0046. Public reporting burden for this collection of information is estimated to average 10 minutes per response, including time for reviewing instructions, searching existing data sources, gathering and maintaining the data needed, and completing and reviewing the collection of information. Send comments regarding the burden estimate or any other aspect of this collection of information, including suggestions for reducing this burden, to the Office of Management and Budget, Paperwork Reduction Project (0348-0046), Washington, DC 20503.

STATE OF FLORIDA DEPARTMENT OF TRANSPORTATION
**NON-COLLUSION DECLARATION AND
COMPLIANCE WITH 49 CFR § 29**

575-060-13
RIGHT OF WAY
05/01
Page 1 of 3

ITEM/SEGMENT NO.: _____
F.A.P. NO.: _____
MANAGING DISTRICT: _____
PARCEL NO.: _____
COUNTY OF: _____
BID LETTING OF: _____

I, _____, hereby declare that I am
(NAME)
_____ of _____
(TITLE) (FIRM)
of _____
(CITY AND STATE)

and that I am the person responsible within my firm for the final decision as to the price(s) and amount of this Bid on this State Project.

I further declare that:

1. The prices(s) and amount of this bid have been arrived at independently, without consultation, communication or agreement, for the purpose of restricting competition with any other contractor, bidder or potential bidder.
2. Neither the price(s) nor the amount of this bid have been disclosed to any other firm or person who is a bidder or potential bidder on this project, and will not be so disclosed prior to the bid opening.
3. No attempt has been made or will be made to solicit, cause or induce any other firm or person to refrain from bidding on this project, or to submit a bid higher than the bid of this firm, or any intentionally high or non-competitive bid or other form of complementary bid.
4. The bid of my firm is made in good faith and not pursuant to any agreement or discussion with, or inducement from, any firm or person to submit a complementary bid.
5. My firm has not offered or entered into a subcontract or agreement regarding the purchase of materials or services from any firm or person, or offered, promised or paid cash or anything of value to any firm or person, whether in connection with this or any other project, in consideration for an agreement or promise by any firm or person to refrain from bidding or to submit a complementary bid on this project.
6. My firm has not accepted or been promised any subcontract or agreement regarding the sale of materials or services to any firm or person, and has not been promised or paid cash or anything of value by any firm or person, whether in connection with this or any other project, in consideration for my firm's submitting a complementary bid, or agreeing to do so, on this project.
7. I have made a diligent inquiry of all members, officers, employees, and agents of my firm with responsibilities relating to the preparation, approval or submission of my firm's bid on this project and have been advised by each of them that he or she has not participated in any communication, consultation, discussion, agreement, collusion, act or other conduct inconsistent with any of the statements and representations made in this Declaration.
8. As required by Section 337.165, Florida Statutes, the firm has fully informed the Department of Transportation in writing of all convictions of the firm, its affiliates (as defined in Section 337.165(1)(a), Florida Statutes), and all directors, officers, and employees of the firm and its affiliates for violation of state or federal antitrust laws with respect to a public contract or for violation of any state or federal law involving fraud, bribery, collusion, conspiracy or material misrepresentation with respect to a public contract. This includes disclosure of the names of current employees of the firm or affiliates who were convicted of contract crimes while in the employ of another company.

9. I certify that, except as noted below, neither my firm nor any person associated therewith in the capacity of owner, partner, director, officer, principal, investigator, project director, manager, auditor, and/or position involving the administration of Federal funds:

- (a) is presently debarred, suspended, proposed for debarment, declared ineligible, or voluntarily excluded from covered transactions, as defined in 49 CFR §29.110(a), by any Federal department or agency;
- (b) has within a three-year period preceding this certification been convicted of or had a civil judgment rendered against him or her for: commission of fraud or a criminal offense in connection with obtaining, attempting to obtain, or performing a Federal, State or local government transaction or public contract; violation of Federal or State antitrust statutes; or commission of embezzlement, theft, forgery, bribery, falsification or destruction of records, making false statements or receiving stolen property;
- (c) is presently indicted for or otherwise criminally or civilly charged by a Federal, State or local governmental entity with commission of any of the offenses enumerated in paragraph 9(b) of this certification; and
- (d) has within a three-year period preceding this certification had one or more Federal, State or local government public transactions terminated for cause or default.

10. I(We), certify that I(We), shall not knowingly enter into any transaction with any subcontractor, material supplier, or vendor who is debarred, suspended, declared ineligible, or voluntarily excluded from participation in this contract by any Federal Agency unless authorized by the Department.

Where I am unable to declare or certify as to any of the statements contained in the above stated paragraphs numbered (1) through (10), I have provided an explanation in the "Exceptions" portion below or by attached separate sheet.

EXCEPTIONS:

(Any exception listed above will not necessarily result in denial of award, but will be considered in determining bidder responsibility. For any exception noted, indicate to whom it applies, initiating agency and dates of agency action. Providing false information may result in criminal prosecution and/or administrative sanctions.)

I declare under penalty of perjury that the foregoing is true and correct.

CONTRACTOR: _____ (Seal)

BY: _____
NAME AND TITLE PRINTED

WITNESS: _____

BY: _____
SIGNATURE

WITNESS: _____

Executed on this _____ day of _____, _____

**FAILURE TO FULLY COMPLETE AND EXECUTE THIS DOCUMENT
MAY RESULT IN THE BID BEING DECLARED NONRESPONSIVE**

REQUIRED CONTRACT PROVISIONS

This certification applies to subcontractors, material suppliers, vendors and other lower tier participants.

- Appendix B of 49 CFR Part 29 –

Appendix B—Certification Regarding Debarment, Suspension, Ineligibility and Voluntary Exclusion—Lower Tier Covered Transactions

Instructions for Certification

1. By signing and submitting this proposal, the prospective lower tier participant is providing the certification set out below.
2. The certification in this clause is a material representation of fact upon which reliance was placed when this transaction was entered. If it is later determined that the prospective lower tier participant knowingly rendered an erroneous certification, in addition to other remedies available to the Federal Government, the department or agency with which this transaction originated may pursue available remedies, including suspension and/or debarment.
3. The prospective lower tier participant shall provide immediate written notice to the person to which this proposal is submitted if at any time the prospective lower tier participant learns that its certification was erroneous when submitted or has become erroneous by reason of changed circumstances.
4. The terms "covered transaction," "debarred," "suspended," "ineligible," "lower tier covered transaction," "participant," "person," "primary covered transaction," "principal," "proposal," and "voluntarily excluded," as used in this clause, have the meanings set out in the Definitions and Coverage sections of rules implementing Executive Order 12549. You may contact the person to whom this proposal is submitted for assistance in obtaining a copy of those regulations.
5. The prospective lower tier participant agrees by submitting this proposal that it shall not knowingly enter into any lower tier covered transaction with a person who is debarred, suspended, declared ineligible, or voluntarily excluded from participation in this covered transaction, unless authorized by the department or agency with which this transaction originated.
6. The prospective lower tier participant further agrees by submitting this proposal that it will include this clause titled "Certification Regarding Debarment, Suspension, Ineligibility and Voluntary Exclusion--Lower Tier Covered Transaction," without modification, in all lower tier covered transactions and in all solicitations for lower tier covered transactions.
7. A participant in a covered transaction may rely upon a certification of a prospective participant in a lower tier covered transaction that it is not debarred, suspended, ineligible, or voluntarily excluded from the covered transaction, unless it knows that the certification is erroneous. A participant may decide the method and frequency by which it determines the eligibility of its principals. Each participant may, but is not required to, check the Nonprocurement List.
8. Nothing contained in the foregoing shall be construed to require establishment of a system of records in order to render in good faith the certification required by this clause. The knowledge and information of a participant is not required to exceed that which is normally possessed by a prudent person in the ordinary course of business dealings.
9. Except for transactions authorized under paragraph 5 of these instructions, if a participant in a covered transaction knowingly enters into a lower tier covered transaction with a person who is suspended, debarred, ineligible, or voluntarily excluded from participation in this transaction, in addition to other remedies available to the Federal Government, the department or agency with which this transaction originated may pursue available remedies, including suspension and/or debarment.

Certification Regarding Debarment, Suspension, Ineligibility and Voluntary Exclusion—Lower Tier Covered Transactions

- (1) The prospective lower tier participant certifies, by submission of this proposal, that neither it nor its principals is presently debarred, suspended, proposed for debarment, declared ineligible, or voluntary excluded from participation in this transaction by any Federal department or agency.
- (2) Where the prospective lower tier participant is unable to certify to any of the statements in this certification, such prospective participant shall attach an explanation to this proposal.

STATE OF FLORIDA DEPARTMENT OF TRANSPORTATION
**CERTIFICATION REGARDING DEBARMENT, SUSPENSION,
 INELIGIBILITY AND VOLUNTARY EXCLUSION-
 LOWER TIER COVERED TRANSACTIONS FOR FEDERAL AID CONTRACTS**
 (Compliance with 2 CFR Parts 180 and 1200)

It is certified that neither the below identified firm nor its principals are presently suspended, proposed for debarment, declared ineligible, or voluntarily excluded from participation in this transaction by any federal department or agency.

Name of Consultant/Contractor: _____

By: _____

Date: _____

Title: _____

Instructions for Certification

Instructions for Certification - Lower Tier Participants:

(Applicable to all subcontracts, purchase orders and other lower tier transactions requiring prior FHWA approval or estimated to cost \$25,000 or more - 2 CFR Parts 180 and 1200)

- a. By signing and submitting this proposal, the prospective lower tier is providing the certification set out below.
- b. The certification in this clause is a material representation of fact upon which reliance was placed when this transaction was entered into. If it is later determined that the prospective lower tier participant knowingly rendered an erroneous certification, in addition to other remedies available to the Federal Government, the department, or agency with which this transaction originated may pursue available remedies, including suspension and/or debarment.
- c. The prospective lower tier participant shall provide immediate written notice to the person to which this proposal is submitted if at any time the prospective lower tier participant learns that its certification was erroneous by reason of changed circumstances.
- d. The terms "covered transaction," "debarred," "suspended," "ineligible," "participant," "person," "principal," and "voluntarily excluded," as used in this clause, are defined in 2 CFR Parts 180 and 1200. You may contact the person to which this proposal is submitted for assistance in obtaining a copy of those regulations. "First Tier Covered Transactions" refers to any covered transaction between a grantee or subgrantee of Federal funds and a participant (such as the prime or general contract). "Lower Tier Covered Transactions" refers to any covered transaction under a First Tier Covered Transaction (such as subcontracts). "First Tier Participant" refers to the participant who has entered into a covered transaction with a grantee or subgrantee of Federal funds (such as the prime or general contractor). "Lower Tier Participant" refers any participant who has entered into a covered transaction with a First Tier Participant or other Lower Tier Participants (such as subcontractors and suppliers).
- e. The prospective lower tier participant agrees by submitting this proposal that, should the proposed covered transaction be entered into, it shall not knowingly enter into any lower tier covered transaction with a person who is debarred, suspended, declared ineligible, or voluntarily excluded from participation in this covered transaction, unless authorized by the department or agency with which this transaction originated.
- f. The prospective lower tier participant further agrees by submitting this proposal that it will include this clause titled "Certification Regarding Debarment, Suspension, Ineligibility and Voluntary Exclusion-Lower Tier Covered Transaction," without modification, in all lower tier covered transactions and in all solicitations for lower tier covered transactions exceeding the \$25,000 threshold.
- g. A participant in a covered transaction may rely upon a certification of a prospective participant in a lower tier covered transaction that is not debarred, suspended, ineligible, or voluntarily excluded from the covered transaction, unless it knows that the certification is erroneous. A participant is responsible for ensuring that its principals are not suspended, debarred, or otherwise ineligible to participate in covered transactions. To verify the eligibility of its principals, as well as the eligibility of any lower tier prospective participants, each participant may, but is not required to, check the Excluded Parties List System website (<https://www.epls.gov/>), which is compiled by the General Services Administration.
- h. Nothing contained in the foregoing shall be construed to require establishment of a system of records in order to render in good faith the certification required by this clause. The knowledge and information of participant is not required to exceed that which is normally possessed by a prudent person in the ordinary course of business dealings.
- i. Except for transactions authorized under paragraph e of these instructions, if a participant in a covered transaction knowingly enters into a lower tier covered transaction with a person who is suspended, debarred, ineligible, or voluntarily excluded from participation in this transaction, in addition to other remedies available to the Federal Government, the department or agency with which this transaction originated may pursue available remedies, including suspension and/or debarment.

LAP DIVISION 1 SPECIFICATIONS.

(REV 2-17-20) (1-21)

Construction Checklist Specifications
from
Department of Transportation
Standard Specifications for Road and Bridge Construction

The following excerpts from the Standard Specifications and Special Provisions are provided for use in LAP Specifications as needed in accordance with the Local Agency Program Checklist for Construction Contracts (Phase 58) – Federal and State Requirements (525-070-44)

FROM SECTION 1 – DEFINITIONS AND TERMS:

Department Name Nassau County

Engineer Nassau County Engineer, acting directly or through duly authorized representatives; such representatives acting within the scope of the duties and authority assigned to them.

Contractor's Engineer of Record.

A Professional Engineer registered in the State of Florida, other than the Engineer of Record or his subcontracted consultant, who undertakes the design and drawing of components of the permanent structure as part of a redesign or Cost Savings Initiative Proposal, or for repair designs and details of the permanent work. The Contractor's Engineer of Record may also serve as the Specialty Engineer.

The Contractor's Engineer of Record must be an employee of a pre-qualified firm. The firm shall be pre-qualified in accordance with the Rules of the Department of Transportation, Chapter 14-75. Any Corporation or Partnership offering engineering services must hold a Certificate of Authorization from the Florida Department of Business and Professional Regulation.

As an alternate to being an employee of a pre-qualified firm, the Contractor's Engineer of Record may be a pre-qualified Specialty Engineer. For items of the permanent work declared by the State Construction Office to be "major" or "structural", the work performed by a pre-qualified Specialty Engineer must be checked by another pre-qualified Specialty Engineer. An individual Engineer may become pre-qualified in the work groups listed in the Rules of the Department of Transportation, Chapter 14-75, if the requirements for the Professional Engineer are met for the individual work groups. Pre-qualified Specialty Engineers are listed on the State Construction Website. Pre-qualified Specialty Engineers will not be authorized to perform redesigns or Cost Savings Initiative Proposal designs of items fully detailed in the plans.

Specialty Engineer.

A Professional Engineer registered in the State of Florida, other than the Engineer of Record or his subcontracted consultant, who undertakes the design and drawing preparation of components, systems, or installation methods and equipment for specific temporary portions of the project work or for special items of the permanent works not fully detailed in the plans and required to be furnished by the Contractor. The Specialty Engineer may also provide designs and details, repair designs and details, or perform Engineering Analyses for items of the permanent work declared by the State Construction Office to be "minor" or "non-structural".

For items of work not specifically covered by the Rules of the Department of Transportation, a Specialty Engineer is qualified if he has the following qualifications:

- (1) Registration as a Professional Engineer in the State of Florida.
- (2) The education and experience necessary to perform the submitted design as required by the Florida Department of Business and Professional Regulation.

FROM SECTION 4 (ALTERATION OF WORK).**4-3 Alteration of Plans or of Character of Work.**

4-3.1 General: The Engineer reserves the right to make, at any time prior to or during the progress of the work, such increases or decreases in quantities, whether a significant change or not, and such alterations in the details of construction, whether a substantial change or not, including but not limited to alterations in the grade or alignment of the road or structure or both, as may be found necessary or desirable by the Engineer. Such increases, decreases or alterations shall not constitute a breach of Contract, shall not invalidate the Contract, nor release the Surety from any liability arising out of this Contract or the Surety bond. The Contractor agrees to perform the work, as altered, the same as if it had been a part of the original Contract.

The term "significant change" applies only when:

1. The Engineer determines that the character of the work as altered differs materially in kind or nature from that involved or included in the original proposed construction, or

2. A major item of work, as defined in 1-3, is increased in excess of 125% or decreased below 75% of the original Contract quantity. The Department will apply any price adjustment for an increase in quantity only to that portion in excess of 125% of the original Contract item quantity in accordance with 4-3.2 below. In the case of a decrease below 75% the Department will only apply a price adjustment for the additional costs that are a direct result of the reduction in quantity.

In (1) above, the determination by the Engineer shall be conclusive. If the determination is challenged by the Contractor in any proceeding, the Contractor must establish by clear and convincing proof that the determination by the Engineer was without any reasonable basis.

4-3.2 Increase, Decrease or Alteration in the Work: The Engineer reserves the right to make alterations in the character of the work which involve a substantial change in the nature of the design or in the type of construction or which materially increases or decreases the cost or time of performance. Such alteration shall not constitute a breach of Contract, shall not invalidate the Contract or release the Surety.

Notwithstanding that the Contractor shall have no formal right whatsoever to any extra compensation or time extension deemed due by the Contractor for any cause unless and until the Contractor follows the procedures set forth in 5-12.2 for preservation, presentation and resolution of the claim, the Contractor may at any time, after having otherwise timely submitted a notice of intent to claim or preliminary time extension request pursuant to 5-12.2 and 8-7.3.2, submit to the Department a request for equitable adjustment of compensation or time or other dispute resolution proposal. The Contractor shall in any request for equitable adjustment of compensation, time, or other dispute resolution proposal certify under oath and in writing, in accordance with the formalities required by Florida law, that the request is made in good faith, that any supportive data submitted is accurate and complete to the Contractor's best knowledge and belief, and that the amount of the request accurately reflects what the Contractor in good faith believes to be the Department's responsibility. Such certification must be made by an officer or director of the Contractor with the authority to bind the Contractor. Any such certified statements of entitlement and costs shall be subject to the audit provisions set forth in 5-12.14. While the submittal or review of a duly certified request for equitable adjustment shall neither create, modify, nor activate any legal rights or obligations as to the Contractor or the Department, the Department will review the content of any duly certified request for equitable adjustment or other dispute

NASSAU COUNTY INVITATION TO BID

NC21-014-ITB - CR-121, S. 14TH ST., CHESTER RD., SADLER RD., & AMELIA CONCOURSE

resolution proposal, with any further action or inaction by the Department thereafter being in its sole discretion. Any request for equitable adjustment that fails to fully comply with the certification requirements will not be reviewed by the Department.

The monetary compensation provided for below constitutes full and complete payment for such additional work and the Contractor shall have no right to any additional monetary compensation for any direct or indirect costs or profit for any such additional work beyond that expressly provided below. The Contractor shall be entitled to a time extension only to the extent that the performance of any portion of the additional work is a controlling work item and the performance of such controlling work item actually extends completion of the project due to no fault of the Contractor. All time related costs for actual performance of such additional work are included in the compensation already provided below and any time extension entitlement hereunder will be without additional monetary compensation. The Contractor shall have no right to any monetary compensation or damages whatsoever for any direct or indirect delay to a controlling work item arising out of or in any way related to the circumstances leading up to or resulting from additional work (but not relating to the actual performance of the additional work, which is paid for as otherwise provided herein), except only as provided for under 5-12.6.2.1.

4-3.2.1 Allowable Costs for Extra Work: The Engineer may direct in writing that extra work be done and, at the Engineer’s sole discretion, the Contractor will be paid pursuant to an agreed Supplemental Agreement or in the following manner:

1. Labor and Burden: The Contractor will receive payment for actual costs of direct labor and burden for the additional or unforeseen work. Labor includes foremen actually engaged in the work; and will not include project supervisory personnel nor necessary on-site clerical staff, except when the additional or unforeseen work is a controlling work item and the performance of such controlling work item actually extends completion of the project due to no fault of the Contractor. Compensation for project supervisory personnel, but in no case higher than a Project Manager’s position, shall only be for the pro-rata time such supervisory personnel spent on the contract. In no case shall an officer or director of the Company, nor those persons who own more than 1% of the Company, be considered as project supervisory personnel, direct labor or foremen hereunder.

Payment for burden shall be limited solely to the following:

Table 4-3.2.1	
Item	Rate
FICA	Rate established by Law
FUTA/SUTA	Rate established by Law
Medical Insurance	Actual
Holidays, Sick & Vacation benefits	Actual
Retirement benefits	Actual
Workers Compensation	Rates based on the National Council on Compensation Insurance basic rate tables adjusted by Contractor’s actual experience modification factor in effect at the time of the additional work or unforeseen work.
Per Diem	Actual but not to exceed State of Florida’s rate
Insurance*	Actual

NASSAU COUNTY INVITATION TO BID
 NC21-014-ITB - CR-121, S. 14TH ST., CHESTER RD., SADLER RD., & AMELIA CONCOURSE

Table 4-3.2.1	
Item	Rate
*Compensation for Insurance is limited solely to General Liability Coverage and does not include any other insurance coverage (such as, but not limited to, Umbrella Coverage, Automobile Insurance, etc.).	

At the Pre-construction conference, certify to the Engineer the following:

- a. A listing of on-site clerical staff, supervisory personnel and their pro-rated time assigned to the contract,
- b. Actual Rate for items listed in Table 4-3.2.1,
- c. Existence of employee benefit plan for Holiday, Sick and Vacation benefits and a Retirement Plan, and,
- d. Payment of Per Diem is a company practice for instances when compensation for Per Diem is requested.

Such certification must be made by an officer or director of the Contractor with authority to bind the Contractor. Timely certification is a condition precedent to any right of the Contractor to recover compensations for such costs, and failure to timely submit the certification will constitute a full, complete, absolute and irrevocable waiver by the Contractor of any right to recover such costs. Any subsequent changes shall be certified to the Engineer as part of the cost proposal or seven calendar days in advance of performing such extra work.

2. Materials and Supplies: For materials accepted by the Engineer and used on the project, the Contractor will receive the actual cost of such materials incorporated into the work, including Contractor paid transportation charges (exclusive of equipment as hereinafter set forth). For supplies reasonably needed for performing the work, the Contractor will receive the actual cost of such supplies.

3. Equipment: For any machinery or special equipment (other than small tools), including fuel and lubricant, the Contractor will receive 100% of the "Rental Rate Blue Book" for the actual time that such equipment is in operation on the work, and 50% of the "Rental Rate Blue Book" for the time the equipment is directed to standby and remain on the project site, to be calculated as indicated below. The equipment rates will be based on the latest edition (as of the date the work to be performed begins) of the "Rental Rate Blue Book for Construction Equipment" as published by EquipmentWatch, a division of Informa Business Media, Inc., using all instructions and adjustments contained therein and as modified below. On all projects, the Engineer will adjust the rates using regional adjustments and Rate Adjustment Tables according to the instructions in the "Rental Rate Blue Book."

Allowable Equipment Rates will be established as set out below:

- a. Allowable Hourly Equipment Rate = Monthly Rate/176
 x Adjustment Factors x 100%.
- b. Allowable Hourly Operating Cost = Hourly Operating
 Cost x 100%.
- c. Allowable Rate Per Hour = Allowable Hourly
 Equipment Rate + Allowable Hourly Operating Cost.
- d. Standby Rate = Allowable Hourly Equipment
 Rate x 50%.

The Monthly Rate is The Basic Machine Rate Plus Any Attachments. Standby rates will apply when equipment is not in operation and is directed by the Engineer to standby at the project site when needed again to complete work and the cost of moving

NASSAU COUNTY INVITATION TO BID

NC21-014-ITB - CR-121, S. 14TH ST., CHESTER RD., SADLER RD., & AMELIA CONCOURSE

the equipment will exceed the accumulated standby cost. Standby rates will not apply on any day the equipment operates for eight or more hours. Standby payment will be limited to only that number of hours which, when added to the operating time for that day equals eight hours. Standby payment will not be made on days that are not normally considered work days on the project.

The Department will allow for the cost of transporting the equipment to and from the location at which it will be used. If the equipment requires assembly or disassembly for transport, the Department will pay for the time to perform this work at the rate for standby equipment.

Equipment may include vehicles utilized only by Labor, as defined above.

4. Indirect Costs, Expenses, and Profit: Compensation for all indirect costs, expenses, and profit of the Contractor, including but not limited to overhead of any kind, whether jobsite, field office, division office, regional office, home office, or otherwise, is expressly limited to the greater of either (a) or (b) below:

a. Solely a mark-up of 17.5% on the payments in (1) through (3), above.

1. Bond: The Contractor will receive compensation for any premium for acquiring a bond for such additional or unforeseen work at the original Contract bond rate paid by the Contractor. No compensation for bond premium will be allowed for additional or unforeseen work paid by the Department via initial contingency pay item.

2. The Contractor will be allowed a markup of 10% on the first \$50,000 and a markup of 5% on any amount over \$50,000 on any subcontract directly related to the additional or unforeseen work. Any such subcontractor mark-up will be allowed only by the prime Contractor and a first tier subcontractor, and the Contractor must elect the markup for any eligible first tier subcontractor to do so.

b. Solely the formula set forth below and only as applied solely as to such number of calendar days of entitlement that are in excess of ten cumulative calendar days as defined below.

$$D = \frac{A \times C}{B}$$

Where A = Original Contract Amount

B = Original Contract Time

C = 8%

D = Average Overhead Per Day

Cumulative Calendar Days is defined as the combined total number of calendar days granted as time extensions due to either extra work, excluding overruns to existing contract items, that extend the duration of the project or delay of a controlling work item caused solely by the Department, or the combined total number of calendar days for which a claim of entitlement to a time extension due to delay of a controlling work item caused solely by the Department is otherwise ultimately determined to be in favor of the Contractor.

No compensation, whatsoever, will be paid to the Contractor for any jobsite overhead and other indirect impacts when the total number of calendar days granted for time extension due to delay of a controlling work item caused solely by the Department is, or

NASSAU COUNTY INVITATION TO BID

NC21-014-ITB - CR-121, S. 14TH ST., CHESTER RD., SADLER RD., & AMELIA CONCOURSE

the total number of calendar days for which entitlement to a time extension due to delay of a controlling work item caused solely by the Department is otherwise ultimately determined in favor of the Contractor to be, equal to or less than ten calendar days and the Contractor also fully assumes all monetary risk of any and all partial or single calendar day delay periods, due to delay of a controlling work item caused solely by the Department, that when combined together are equal to or less than ten calendar days and regardless of whether monetary compensation is otherwise provided for hereunder for one or more calendar days of time extension entitlement for each calendar day exceeding ten calendar days. All calculations under this provision shall exclude weather days, Holidays, and Special Events.

Further, for (a) and (b) above, in the event there are concurrent delays to one or more controlling work items, one or more being caused by the Department and one or more being caused by the Contractor, the Contractor shall be entitled to a time extension for each day that a controlling work item is delayed by the Department but shall have no right to nor receive any monetary compensation for any indirect costs for any days of concurrent delay.

4-3.2.2 Subcontracted Work: Compensation for the additional or unforeseen work performed by a subcontractor shall be limited solely to that provided for in 4-3.2.1 (1), (2), (3) and (4)(a). In addition, the Contractor compensation is expressly limited to the greater of the total provided in either 4-3.2.1(4)(a) or (4)(b), except that the Average Overhead Per-Day calculation is as follows:

$$D_s = \frac{A_s \times C}{B}$$

Where A_s = Original Contract Amount minus Original

Subcontract amounts(s)*

B = Original Contract Time

C = 8%

D_s = Average Overhead Per-Day

* deduct Original Subcontract Amount(s) of subcontractor(s) performing the work

The subcontractor may receive compensation for any premium for acquiring a bond for the additional or unforeseen work; provided, however, that such payment for additional subcontractor bond will only be paid upon presentment to the Department of clear and convincing proof that the subcontractor has actually submitted and paid for separate bond premiums for such additional or unforeseen work in such amount and that the subcontractor was required by the Contractor to acquire a bond.

The Contractor shall require the subcontractor to submit a certification, in accordance with 4-3.2.1 (1), as part of the cost proposal and submit such to the Engineer. Such certification must be made by an officer or director of the subcontractor with authority to bind the subcontractor. Timely certification is a condition precedent to any right of the Contractor to recover compensation for such subcontractor costs, and failure to timely submit the certification will constitute a full, complete, absolute and irrevocable waiver by the Contractor of any right to recover such subcontractor costs.

4-3.3 No Waiver of Contract: Changes made by the Engineer will not be considered to waive any of the provisions of the Contract, nor may the Contractor make any claim for loss of anticipated profits because of the changes, or by reason of any variation between the approximate quantities and the quantities of work actually performed. All work shall be performed as directed by the Engineer and in accordance with the Contract Documents.

4-3.4 Conditions Requiring a Supplemental Agreement or Unilateral Payment: A Supplemental Agreement or Unilateral Payment will be used to clarify the Plans and Specifications of the Contract; to provide for unforeseen work, grade changes, or alterations in the Plans which could not reasonably have been contemplated or foreseen in the original Plans and Specifications; to change the limits of construction to meet field conditions; to provide a safe and functional connection to an existing pavement; to settle documented Contract claims; to make the project functionally operational in accordance with the intent of the original Contract and subsequent amendments thereto.

A Supplemental Agreement or Unilateral Payment may be used to expand the physical limits of the project only to the extent necessary to make the project functionally operational in accordance with the intent of the original Contract. The cost of any such agreement extending the physical limits of the project shall not exceed \$100,000 or 10% of the original Contract price, whichever is greater.

Perform no work to be covered by a Supplemental Agreement or Unilateral Payment before written authorization is received from the Engineer. The Engineer's written authorization will set forth sufficient work information to allow the work to begin. The work activities, terms and conditions will be reduced to written Supplemental Agreement or Unilateral Payment form promptly thereafter. No payment will be made on a Supplemental Agreement or Unilateral Payment prior to the Department's approval of the document.

4-3.5 Extra Work: Extra work authorized in writing by the Engineer will be paid in accordance with the formula in 4-3.2. Such payment will be the full extent of all monetary compensation entitlement due to the Contractor for such extra work. Any entitlement to a time extension due to extra work will be limited solely to that provided for in 4-3.2 for additional work.

4-3.6 Connections to Existing Pavement, Drives and Walks: Generally adhere to the limits of construction at the beginning and end of the project as detailed in the Plans. However, if the Engineer determines that it is necessary to extend the construction in order to make suitable connections to existing pavement, the Engineer will authorize such a change in writing.

For necessary connections to existing walks and drives that are not indicated in the Plans, the Engineer will submit direction regarding the proper connections in accordance with the Standard Plans.

4-3.7 Differing Site Conditions: During the progress of the work, if subsurface or latent physical conditions are encountered at the site differing materially from those indicated in the Contract, or if unknown physical conditions of an unusual nature differing materially from those ordinarily encountered and generally recognized as inherent in the work provided for in the Contract are encountered at the site, the party discovering such conditions shall promptly notify the other party in writing of the specific differing conditions before the Contractor disturbs the conditions or performs the affected work.

Upon receipt of written notification of differing site conditions from the Contractor, the Engineer will investigate the conditions, and if it is determined that the conditions materially differ and cause an increase or decrease in the cost or time required for the performance of any work under the Contract, an adjustment will be made, excluding loss of anticipated profits, and the

Contract will be modified in writing accordingly. The Engineer will notify the Contractor whether or not an adjustment of the Contract is warranted.

The Engineer will not allow a Contract adjustment for a differing site condition unless the Contractor has submitted the required written notice.

The Engineer will not allow a Contract adjustment under this clause for any effects caused to any other Department or non-Department projects on which the Contractor may be working.

4-3.8 Changes Affecting Utilities: The Contractor shall be responsible for identifying and assessing any potential impacts to a utility that may be caused by the changes proposed by the Contractor, and the Contractor shall at the time of making the request for a change notify the Department in writing of any such potential impacts to utilities.

Department approval of a Contractor proposed change does not relieve the Contractor of sole responsibility for all utility impacts, costs, delays or damages, whether direct or indirect, resulting from Contractor initiated changes in the design or construction activities from those in the original Contract Specifications, Design Plans (including Traffic Control Plans) or other Contract Documents and which effect a change in utility work different from that shown in the Utility Plans, joint project agreements or utility relocation schedules.

4-3.9 Cost Savings Initiative Proposal:

4-3.9.1 Intent and Objective:

1. This Subarticle applies to any cost reduction proposal (hereinafter referred to as a Proposal) that the Contractor initiates and develops for the purpose of refining the Contract to increase cost effectiveness or significantly improve the quality of the end result. A mandatory Cost Savings Initiative Workshop will be held prior to Contract Time beginning for the Contractor and Department to discuss potential Proposals. This mandatory workshop can only be eliminated if agreed to in writing by both the Contractor and Department. This Subarticle does not, however, apply to any such proposal unless the Contractor identifies it at the time of its submission to the Department as a proposal submitted pursuant to this Subarticle.

2. The Department will consider Proposals that would result in net savings to the Department by providing a decrease in the cost of the Contract. Proposals must result in savings without impairing essential functions and characteristics such as safety, service, life, reliability, economy of operation, ease of maintenance, aesthetics and necessary standard design features. The Department will not recognize the Contractor's correction of plan errors that result in a cost reduction, as a Proposal. Deletions of work, approved by the Engineer which are not directly associated with or integral to a Proposal will be handled as full credit to the Department for the work deleted.

3. The Department shall have the right to reject, at its discretion, any Proposal submitted that proposes a change in the design of the pavement system or that would require additional right-of-way. Pending the Department's execution of a formal supplemental agreement implementing an approved Proposal, the Contractor shall remain obligated to perform the work in accordance with the terms of the existing Contract. The Department may grant time extensions to allow for the time required to develop and review a Proposal.

4. For potential Proposals not discussed at the Cost Savings Initiative Workshop, a mandatory concept meeting will be held for the Contractor and Department to discuss the potential Proposal prior to development of the Proposal. This mandatory meeting can only be eliminated if agreed to in writing by both the Contractor and Department.

4-3.9.2 Subcontractors: The Department encourages the Contractor to include the provisions of this Subarticle in Contracts with subcontractors and to encourage submission of Proposals from subcontractors. However, it is not mandatory to submit Proposals to the Department or to accept or transmit subcontractor proposed Proposals to the Department.

4-3.9.3 Data Requirements: As a minimum, submit the following information with each Proposal:

1. a description of the difference between the existing Contract requirement, including any time extension request, and the proposed change, and the comparative advantages and disadvantages.

2. separate detailed cost estimates for both the existing Contract requirement and the proposed change. Break down the cost estimates by pay item numbers indicating quantity increases or decreases and deleted pay items. Identify additional proposed work not covered by pay items within the Contract, by using pay item numbers in the Basis of Estimates Manual. In preparing the estimates, include overhead, profit, and bond within pay items in the Contract. Separate pay item(s) for the cost of overhead, profit, and bond will not be allowed.

3. an itemization of the changes, deletions or additions to plan details, plan sheets, Standard Plans and Specifications that are required to implement the Proposal if the Department adopts it. Submit preliminary plan drawings sufficient to describe the proposed changes.

4. engineering or other analysis in sufficient detail to identify and describe specific features of the Contract that must be changed if the Department accepts the Proposal with a proposal as to how these changes can be accomplished and an assessment of their effect on other project elements. The Department may require that engineering analyses be performed by a prequalified consultant in the applicable class of work. Support all design changes that result from the Proposal with drawings and computations signed and sealed by the Contractor's Engineer of Record. Written documentation or drawings will be submitted clearly delineating the responsibility of the Contractor's Engineer of Record.

5. the date by which the Department must approve the Proposal to obtain the total estimated cost reduction during the remainder of the Contract, noting any effect on the Contract completion time or delivery schedule.

6. a revised project schedule that would be followed upon approval of the Proposal. This schedule would include submittal dates and review time for the Department and Peer reviews.

4-3.9.4 Processing Procedures: Submit Proposals to the Engineer or his duly authorized representative. The Department will process Proposals expeditiously; however, the Department is not liable for any delay in acting upon a Proposal submitted pursuant to this Subarticle. The Contractor may withdraw, in whole or in part, a Proposal not accepted by the Department within the period specified in the Proposal. The Department is not liable for any Proposal development cost in the case where the Department rejects or the Contractor withdraws a Proposal.

The Engineer is the sole judge of the acceptability of a Proposal and of the estimated net savings in construction costs from the adoption of all or any part of such proposal. In determining the estimated net savings, the Department reserves the right to disregard the Contract bid prices if, in the judgment of the Engineer, such prices do not represent a fair measure of the value of work to be performed or to be deleted.

Prior to approval, the Engineer may modify a Proposal, with the concurrence of the Contractor, to make it acceptable. If any modification increases or decreases the net savings resulting from the Proposal, the Department will determine the Contractor's fair share upon the basis of the Proposal as modified and upon the final quantities. The Department will compute the net savings by subtracting the revised total cost of all bid items affected by the Proposal from the total cost of the same bid items as represented in the original Contract.

Prior to approval of the Proposal that initiates the supplemental agreement, submit acceptable Contract-quality plan sheets revised to show all details consistent with the Proposal design.

4-3.9.5 Computations for Change in Contract Cost of Performance: If the Proposal is adopted, the Contractor's share of the net savings as defined hereinafter represents full compensation to the Contractor for the Proposal.

The Department will not include its costs to process and implement a Proposal in the estimate. However, the Department reserves the right, where it deems such action appropriate, to require the Contractor to pay the Department's cost of investigating and implementing a Proposal as a condition of considering such proposal. When the Department imposes such a condition, the Contractor shall accept this condition in writing, authorizing the Department to deduct amounts payable to the Department from any monies due or that may become due to the Contractor under the Contract.

4-3.9.6 Conditions of Acceptance for Major Design Modifications of Category 2 Bridges: A Proposal that proposes major design modifications of a category 2 bridge, as determined by the Engineer, shall have the following conditions of acceptance:

All bridge Plans relating to the Proposal shall undergo an independent peer review conducted by a single independent engineering firm referred to for the purposes of this article as the Independent Review Engineer who is not the originator of the Proposal design, and is pre-qualified by the Department in accordance with Rule 14-75, Florida Administrative Code. The independent peer review is intended to be a comprehensive, thorough verification of the original work, giving assurance that the design is in compliance with all Department requirements. The Independent Review Engineer's comments, along with the resolution of each comment, shall be submitted to the Department. The Independent Review Engineer shall sign and seal the submittal cover letter stating that all comments have been adequately addressed and the design is in compliance with the Department requirements. If there are any unresolved comments the Independent Review Engineer shall specifically list all unresolved issues in the signed and sealed cover letter.

The Contractor shall designate a primary engineer responsible for the Proposal design and as such will be designated as the Contractor's Engineer of Record for the Proposal design. The Department reserves the right to require the Contractor's Engineer of Record to assume responsibility for design of the entire structure.

New designs and independent peer reviews shall be in compliance with all applicable Department, FHWA and AASHTO criteria requirements including bridge load ratings.

4-3.9.7 Sharing Arrangements: If the Department approves a Proposal, the Contractor shall receive 50% of the net reduction in the cost of performance of the Contract as determined by the final negotiated agreement between the Contractor and the Department. The net reduction will be determined by subtracting from the savings of the construction costs the reasonable documented engineering costs incurred by the contractor to design and develop a Proposal. The reasonable documented engineering costs will be paid by the Department.

Engineering costs will be based on the consultant's certified invoice and may include the costs of the Independent Review Engineer in 4-3.9.6. The total engineering costs to be subtracted from the savings to determine the net reduction will be limited to 25% of the construction savings and shall not include any markup by the Contractor or the costs for engineering services performed by the Contractor.

4-3.9.8 Notice of Intellectual Property Interests and Department's Future Rights to a Proposal:

4-3.9.8.1 Notice of Intellectual Property Interests: The Contractor's Proposal submittal shall identify with specificity any and all forms of intellectual property rights that either the Contractor or any officer, shareholder, employee, consultant, or affiliate, of the Contractor, or any other entity who contributed in any measure to the substance of the Contractor's Proposal development, have or may have that are in whole or in part implicated in the Proposal. Such required intellectual property rights notice includes, but is not limited to, disclosure of any issued patents, copyrights, or licenses; pending patent, copyright or license applications; and any intellectual property rights that though not yet issued, applied for or intended to be pursued, could nevertheless otherwise be subsequently the subject of patent, copyright or license protection by the Contractor or others in the future. This notice requirement does not extend to intellectual property rights as to stand-alone or integral components of the Proposal that are already on the Department's Approved Product List (APL) or Standard Plans, or are otherwise generally known in the industry as being subject to patent or copyright protection.

4-3.9.8.2 Department's Future Rights to a Proposal: Notwithstanding 7-3 nor any other provision of the Standard Specifications, upon acceptance of a Proposal, the Contractor hereby grants to the Department and its contractors (such grant being expressly limited solely to any and all existing or future Department construction projects and any other Department projects that are partially or wholly funded by or for the Department) a royalty-free and perpetual license under all forms of intellectual property rights to manufacture, to use, to design, to construct, to disclose, to reproduce, to prepare and fully utilize derivative works, to distribute, display and publish, in whole or in part, and to permit others to do any of the above, and to otherwise in any manner and for any purpose whatsoever do anything reasonably necessary to fully utilize any and all aspects of such Proposal on any and all existing and future construction projects and any other Department projects.

Contractor shall hold harmless, indemnify and defend the Department and its contractors and others in privity therewith from and against any and all claims, liabilities, other obligations or losses, and reasonable expenses related thereto (including reasonable attorneys' fees), which are incurred or are suffered by any breach of the foregoing grants, and regardless of whether such intellectual property rights were or were not disclosed by the Contractor pursuant to 4-3.9.8.1, unless the Department has by express written exception in the Proposal acceptance process specifically released the Contractor from such obligation to hold harmless, indemnify and defend as to one or more disclosed intellectual property rights.

FROM SECTION 5 – CONTROL OF THE WORK (CLAIMS).

5-12 Claims by Contractor.

5-12.1 General: When the Contractor deems that extra compensation or a time extension is due beyond that agreed to by the Engineer, whether due to delay, additional work, altered work, differing site conditions, breach of Contract, or for any other cause, the Contractor shall follow the procedures set forth herein for preservation, presentation and resolution of the claim.

NASSAU COUNTY INVITATION TO BID
NC21-014-ITB - CR-121, S. 14TH ST., CHESTER RD., SADLER RD., & AMELIA CONCOURSE

Submission of timely notice of intent to file a claim, preliminary time extension request, time extension request, and the certified written claim, together with full and complete claim documentation, are each a condition precedent to the Contractor bringing any circuit court, arbitration, or other formal claims resolution proceeding against the Department for the items and for the sums or time set forth in the Contractor's certified written claim. The failure to provide such notice of intent, preliminary time extension request, time extension request, certified written claim and full and complete claim documentation within the time required shall constitute a full, complete, absolute and irrevocable waiver by the Contractor of any right to additional compensation or a time extension for such claim.

5-12.2 Notice of Claim:

5-12.2.1 Claims For Extra Work: Where the Contractor deems that additional compensation or a time extension is due for work or materials not expressly provided for in the Contract or which is by written directive expressly ordered by the Engineer pursuant to 4-3, the Contractor shall submit written notification to the Engineer of the intention to make a claim for additional compensation before beginning the work on which the claim is based, and if seeking a time extension, the Contractor shall also submit a preliminary request for time extension pursuant to 8-7.3.2 within ten calendar days after commencement of a delay and a request for Contract Time extension pursuant to 8-7.3.2 within thirty calendar days after the elimination of the delay. If such written notification is not submitted and the Engineer is not afforded the opportunity for keeping strict account of actual labor, material, equipment, and time, the Contractor waives the claim for additional compensation or a time extension. Such notice by the Contractor, and the fact that the Engineer has kept account of the labor, materials and equipment, and time, shall not in any way be construed as establishing the validity of the claim or method for computing any compensation or time extension for such claim. On projects with an original Contract amount of \$3,000,000 or less within 90 calendar days after final acceptance of the project and on projects with an original Contract amount greater than \$3,000,000 within 180 calendar days after final acceptance of the project the Contractor shall submit full and complete claim documentation as described in 5-12.3 and duly certified pursuant to 5-12.9. However, for any claim or part of a claim that pertains solely to final estimate quantities disputes the Contractor shall submit full and complete claim documentation as described in 5-12.3 and duly certified pursuant to 5-12.9, as to such final estimate claim dispute issues, within 90 or 180 calendar days, respectively, of the Contractor's receipt of the Department's final estimate.

If the Contractor fails to submit a certificate of claim as described in 5-12.9, the Department will so notify the Contractor in writing. The Contractor shall have ten calendar days from receipt of the notice to resubmit the claim documentation, without change, with a certificate of claim as described in 5-12.9, without regard to whether the resubmission is within the applicable 90 or 180 calendar day deadline for submission of full and complete claim documentation. Failure by the Contractor to comply with the ten calendar day notice shall constitute a waiver of the claim.

5-12.2.2 Claims For Delay: Where the Contractor deems that additional compensation or a time extension is due on account of delay, differing site conditions, breach of Contract, or any other cause other than for work or materials not expressly provided for in the Contract (Extra Work) or which is by written directive of the Engineer expressly ordered by the Engineer pursuant to 4-3, the Contractor shall submit a written notice of intent to the Engineer within ten days after commencement of a delay to a controlling work item expressly notifying the Engineer that the Contractor intends to seek additional compensation, and if seeking a time

NASSAU COUNTY INVITATION TO BID

NC21-014-ITB - CR-121, S. 14TH ST., CHESTER RD., SADLER RD., & AMELIA CONCOURSE

extension, the Contractor shall also submit a preliminary request for time extension pursuant to 8-7.3.2 within ten calendar days after commencement of a delay to a controlling work item, as to such delay and providing a reasonably complete description as to the cause and nature of the delay and the possible impacts to the Contractor's work by such delay, and a request for Contract Time extension pursuant to 8-7.3.2 within thirty calendar days after the elimination of the delay. On projects with an original Contract amount of \$3,000,000 or less within 90 calendar days after final acceptance of the project and on projects with an original Contract amount greater than \$3,000,000 within 180 calendar days after final acceptance of the project the Contractor shall submit full and complete documentation as described in 5-12.3 and duly certified pursuant to 5-12.9.

If the Contractor fails to submit a certificate of claim as described in 5-12.9, the Department will so notify the Contractor in writing. The Contractor shall have ten calendar days from receipt of the notice to resubmit the claim documentation, without change, with a certificate of claim as described in 5-12.9, without regard to whether the resubmission is within the applicable 90 or 180 calendar day deadline for submission of full and complete claim documentation. Failure by the Contractor to comply with the ten calendar day notice shall constitute a waiver of the claim.

There shall be no Contractor entitlement to any monetary compensation or time extension for any delays or delay impacts, whatsoever, that are not to a controlling work item, and then as to any such delay to a controlling work item entitlement to any monetary compensation or time extension shall only be to the extent such is otherwise provided for expressly under 4-3 or 5-12, except that in the instance of delay to a non-controlling item of work the Contractor may be compensated for the direct costs of idle labor or equipment only, at the rates set forth in 4-3.2.1(1) and (3), and then only to the extent the Contractor could not reasonably mitigate such idleness.

If the Contractor provides the written notice of intent, the preliminary request for time extension, and the request for Contract Time extension in compliance with the aforementioned time and content requirements, the Contractor's claim for delay to a controlling work item will be evaluated as of the date of the elimination of the delay even if the Contractor's performance subsequently overcomes the delay. If the claim for delay has not been settled, the Contractor must also comply with 5-12.3 and 5-12.9 to preserve the claim.

5-12.3 Content of Written Claim: As a condition precedent to the Contractor being entitled to additional compensation or a time extension under the Contract, for any claim, the Contractor shall submit a certified written claim to the Department which will include for each individual claim, at a minimum, the following information:

1. A detailed factual statement of the claim providing all necessary dates, locations, and items of work affected and included in each claim;
2. The date or dates on which actions resulting in the claim occurred or conditions resulting in the claim became evident;
3. Identification of all pertinent documents and the substance of any material oral communications relating to such claim and the name of the persons making such material oral communications;
4. Identification of the provisions of the Contract which support the claim and a statement of the reasons why such provisions support the claim, or alternatively, the provisions of the Contract which allegedly have been breached and the actions constituting such breach;
5. A detailed compilation of the amount of additional compensation sought and a breakdown of the amount sought as follows:
 - a. documented additional job site labor expenses;

- b. documented additional cost of materials and supplies;
- c. a list of additional equipment costs claimed, including each piece of equipment and the rental rate claimed for each;
- d. any other additional direct costs or damages and the documents in support thereof;
- e. any additional indirect costs or damages and all documentation in support thereof.

6. A detailed compilation of the specific dates and the exact number of calendar days sought for a time extension, the basis for entitlement to time for each day, all documentation of the delay, and a breakout of the number of days claimed for each identified event, circumstance or occurrence.

Further, the Contractor shall be prohibited from amending either the bases of entitlement or the amount of any compensation or time stated for any and all issues claimed in the Contractor's written claim submitted hereunder, and any circuit court, arbitration, or other formal claims resolution proceeding shall be limited solely to the bases of entitlement and the amount of any compensation or time stated for any and all issues claimed in the Contractor's written claim submitted hereunder. This shall not, however, preclude a Contractor from withdrawing or reducing any of the bases of entitlement and the amount of any compensation or time stated for any and all issues claimed in the Contractor's written claim submitted hereunder at any time.

5-12.4 Action on Claim: The Engineer will respond in writing on projects with an original Contract amount of \$3,000,000 or less within 90 calendar days of receipt of a complete claim submitted by a Contractor in compliance with 5-12.3, and on projects with an original Contract amount greater than \$3,000,000 within 120 calendar days of receipt of a complete claim submitted by a Contractor in compliance with 5-12.3. Failure by the Engineer to respond to a claim in writing within 90 or 120 days, respectively, after receipt of a complete claim submitted by the Contractor in compliance with 5-12.3 constitutes a denial of the claim by the Engineer. If the Engineer finds the claim or any part thereof to be valid, such partial or whole claim will be allowed and paid for to the extent deemed valid and any time extension granted, if applicable, as provided in the Contract. No circuit court or arbitration proceedings on any claim, or a part thereof, may be filed until after final acceptance of all Contract work by the Department or denial hereunder, whichever occurs last.

5-12.5 Pre-Settlement and Pre-Judgment Interest: Entitlement to any pre-settlement or pre-judgment interest on any claim amount determined to be valid subsequent to the Department's receipt of a certified written claim in full compliance with 5-12.3, whether determined by a settlement or a final ruling in formal proceedings, the Department shall pay to the Contractor simple interest calculated at the Prime Rate (as reported by the Wall Street Journal as the base rate on corporate loans posted by at least 75% of the nations 30 largest banks) as of the 60th calendar day following the Department's receipt of a certified written claim in full compliance with 5-12.3, such interest to accrue beginning 60 calendar days following the Department's receipt of a certified written claim in full compliance with 5-12.3 and ending on the date of final settlement or formal ruling.

5-12.6 Compensation for Extra Work or Delay:

5-12.6.1 Compensation for Extra Work: Notwithstanding anything to the contrary contained in the Contract Documents, the Contractor shall not be entitled to any compensation beyond that provided for in 4-3.2.

5-12.6.2 Compensation for Delay: Notwithstanding anything to the contrary contained in the Contract Documents, the additional compensation set forth in 5-12.6.2.1 shall be the Contractor's sole monetary remedy for any delay other than to perform extra work caused by the Department unless the delay shall have been caused by acts constituting willful or intentional interference by the Department with the Contractor's performance of the work and then only where such acts continue after Contractor's written notice to the Department of such interference. The parties anticipate that delays may be caused by or arise from any number of events during the term of the Contract, including, but not limited to, work performed, work deleted, supplemental agreements, work orders, disruptions, differing site conditions, utility conflicts, design changes or defects, time extensions, extra work, right-of-way issues, permitting issues, actions of suppliers, subcontractors or other contractors, actions by third parties, suspensions of work by the Engineer shop drawing approval process delays, expansion of the physical limits of the project to make it functional, weather, weekends, holidays, special events, suspension of Contract Time, or other events, forces or factors sometimes experienced in construction work. Such delays or events and their potential impacts on the performance by the Contractor are specifically contemplated and acknowledged by the parties in entering into this Contract, and shall not be deemed to constitute willful or intentional interference with the Contractor's performance of the work without clear and convincing proof that they were the result of a deliberate act, without reasonable and good-faith basis, and specifically intended to disrupt the Contractor's performance.

5-12.6.2.1 Compensation for Direct Costs, Indirect Costs, Expenses, and Profit thereon, of or from Delay: For any delay claim, the Contractor shall be entitled to monetary compensation for the actual idle labor (including supervisory personnel) and equipment, and indirect costs, expenses, and profit thereon, as provided for in 4-3.2.1(4) and solely for costs incurred beyond what reasonable mitigation thereof the Contractor could have undertaken.

5-12.7 Mandatory Claim Records: After submitting to the Engineer a notice of intent to file a claim for extra work or delay, the Contractor must keep daily records of all labor, material and equipment costs incurred for operations affected by the extra work or delay. These daily records must identify each operation affected by the extra work or delay and the specific locations where work is affected by the extra work or delay, as nearly as possible. The Engineer may also keep records of all labor, material and equipment used on the operations affected by the extra work or delay. The Contractor shall, once a notice of intent to claim has been timely filed, and not less than weekly thereafter as long as appropriate, submit the Contractor's daily records to the Engineer and be likewise entitled to receive the Department's daily records. The daily records to be submitted hereunder shall be done at no cost to the recipient.

5-12.8 Claims For Acceleration: The Department shall have no liability for any constructive acceleration of the work, nor shall the Contractor have any right to make any claim for constructive acceleration nor include the same as an element of any claim the Contractor may otherwise submit under this Contract. If the Engineer gives express written direction for the Contractor to accelerate its efforts, such written direction will set forth the prices and other pertinent information and will be reduced to a written Contract Document promptly. No payment will be made on a Supplemental Agreement for acceleration prior to the Department's approval of the documents.

5-12.9 Certificate of Claim: When submitting any claim, the Contractor shall certify under oath and in writing, in accordance with the formalities required by Florida law, that the claim is made in good faith, that the supportive data are accurate and complete to the Contractor's best knowledge and belief, and that the amount of the claim accurately reflects what the Contractor in

good faith believes to be the Department's liability. Such certification must be made by an officer or director of the Contractor with the authority to bind the Contractor.

5-12.10 Non-Recoverable Items: The parties agree that for any claim the Department will not have liability for the following items of damages or expense:

1. Loss of profit, incentives or bonuses;
2. Any claim for other than extra work or delay;
3. Consequential damages, including, but not limited to, loss of bonding capacity, loss of bidding opportunities, loss of credit standing, cost of financing, interest paid, loss of other work or insolvency;
4. Acceleration costs and expenses, except where the Department has expressly and specifically directed the Contractor in writing "to accelerate at the Department's expense"; nor
5. Attorney fees, claims preparation expenses and costs of litigation.

5-12.11 Exclusive Remedies: Notwithstanding any other provision of this Contract, the parties agree that the Department shall have no liability to the Contractor for expenses, costs, or items of damages other than those which are specifically identified as payable under 5-12. In the event any legal action for additional compensation, whether on account of delay, acceleration, breach of contract, or otherwise, the Contractor agrees that the Department's liability will be limited to those items which are specifically identified as payable in 5-12.

5-12.12 Settlement Discussions: The content of any discussions or meetings held between the Department and the Contractor to settle or resolve any claims submitted by the Contractor against the Department shall be inadmissible in any legal, equitable, arbitration or administrative proceedings brought by the Contractor against the Department for payment of such claim. Dispute Resolution Board, State Arbitration Board and Claim Review Committee proceedings are not settlement discussions, for purposes of this provision.

5-12.13 Personal Liability of Public Officials: In carrying out any of the provisions of the Contract or in exercising any power or authority granted to the Secretary of Transportation, Engineer or any of their respective employees or agents, there shall be no liability on behalf of any employee, officer or official of the Department for which such individual is responsible, either personally or as officials or representatives of the Department. It is understood that in all such matters such individuals act solely as agents and representatives of the Department.

5-12.14 Auditing of Claims: All claims filed against the Department shall be subject to audit at any time following the filing of the claim, whether or not such claim is part of a suit pending in the Courts of this State. The audit may be performed, at the Department's sole discretion, by employees of the Department or by any independent auditor appointed by the Department, or both. The audit may begin after ten days written notice to the Contractor, subcontractor, or supplier. The Contractor, subcontractor, or supplier shall make a good faith effort to cooperate with the auditors. As a condition precedent to recovery on any claim, the Contractor, subcontractor, or supplier must retain sufficient records, and provide full and reasonable access to such records, to allow the Department's auditors to verify the claim and failure to retain sufficient records of the claim or failure to provide full and reasonable access to such records shall constitute a waiver of that portion of such claim that cannot be verified and shall bar recovery thereunder. Further, and in addition to such audit access, upon the Contractor submitting a written claim, the Department shall have the right to request and receive, and the Contractor shall have the affirmative obligation to submit to the Department any and all documents in the possession of the Contractor or its subcontractors, materialmen or suppliers as may be deemed relevant by the Department in its review of the basis, validity or value of the Contractor's claim.

Without limiting the generality of the foregoing, the Contractor shall upon written request of the Department make available to the Department's auditors, or upon the Department's written request, submit at the Department's expense, any or all of the following documents:

1. Daily time sheets and foreman's daily reports and diaries;
2. Insurance, welfare and benefits records;
3. Payroll register;
4. Earnings records;
5. Payroll tax return;
6. Material invoices, purchase orders, and all material and supply acquisition contracts;
7. Material cost distribution worksheet;
8. Equipment records (list of company owned, rented or other equipment used);
9. Vendor rental agreements and subcontractor invoices;
10. Subcontractor payment certificates;
11. Canceled checks for the project, including, payroll and vendors;
12. Job cost report;
13. Job payroll ledger;
14. General ledger, general journal, (if used) and all subsidiary ledgers and journals together with all supporting documentation pertinent to entries made in these ledgers and journals;
15. Cash disbursements journal;
16. Financial statements for all years reflecting the operations on this project;
17. Income tax returns for all years reflecting the operations on this project;
18. All documents which reflect the Contractor's actual profit and overhead during the years this Contract was being performed and for each of the five years prior to the commencement of this Contract;
19. All documents related to the preparation of the Contractor's bid including the final calculations on which the bid was based;
20. All documents which relate to each and every claim together with all documents which support the amount of damages as to each claim;
21. Worksheets used to prepare the claim establishing the cost components for items of the claim including, but not limited to, labor, benefits and insurance, materials, equipment, subcontractors, and all documents that establish which time periods and individuals were involved, and the hours and rates for such individuals.

FROM SECTION 6 – CONTROL OF MATERIALS (CONVICT LABOR AND BUY AMERICA).

6-5 Products and Source of Supply.

6-5.1 Source of Supply–Convict Labor (Federal-Aid Contracts Only): Do not use materials that were produced after July 1, 1991, by convict labor for Federal-aid highway construction projects unless the prison facility has been producing convict-made materials for Federal-aid highway construction projects before July 1, 1987.

Use materials that were produced prior to July 2, 1991, by convicts on Federal-aid highway construction projects free from the restrictions placed on the use of these materials by

23 U.S.C. 114. The Department will limit the use of materials produced by convict labor for use in Federal-aid highway construction projects to:

1. Materials produced by convicts on parole, supervised release, or probation from a prison or,
2. Materials produced in a qualified prison facility.

The amount of such materials produced for Federal-aid highway construction during any 12-month period shall not exceed the amount produced in such facility for use in such construction during the 12-month period ending July 1, 1987.

6-5.2 Source of Supply-Steel: Use steel and iron manufactured in the United States, in accordance with the Buy America provisions of 23 CFR 635.410, as amended. Ensure that all manufacturing processes for this material occur in the United States. As used in this specification, a manufacturing process is any process that modifies the chemical content, physical shape or size, or final finish of a product, beginning with the initial melting and continuing through the final shaping and coating. If a steel or iron product is taken outside the United States for any manufacturing process, it becomes foreign source material. When using steel or iron materials as a component of any manufactured product (e.g., concrete pipe, prestressed beams, corrugated steel pipe, etc.), these same provisions apply. Foreign steel and iron may be used when the total actual cost of such foreign materials does not exceed 0.1% of the total Contract amount or \$2,500, whichever is greater. These requirements are applicable to all steel and iron materials incorporated into the finished work, but are not applicable to steel and iron items that the Contractor uses but does not incorporate into the finished work. Submit a certification from the manufacturer of steel or iron, or any product containing steel or iron, stating that all steel or iron furnished or incorporated into the furnished product was produced and manufactured in the United States or a statement that the product was produced within the United States except for minimal quantities of foreign steel and iron valued at \$ (actual cost). Submit each such certification to the Engineer prior to incorporating the material or product into the project. Prior to the use of foreign steel or iron materials on a project, submit invoices to document the actual cost of such material, and obtain the Engineer's written approval prior to incorporating the material into the project

FROM SECTION 7 – LEGAL REQUIREMENTS AND RESPONSIBILITIES TO THE PUBLIC (FHWA 1273, WAGE RATES, E-VERIFY, TITLE VI, DBE, AND ON-THE-JOB TRAINING)

Compliance with FHWA 1273: The FHWA-1273 Electronic version, dated May 1, 2012 is posted on the Department's website at the following URL address

https://fdotwww.blob.core.windows.net/sitefinity/docs/default-source/programmanagement/implemented/urlinspecs/files/deo112468a91904c88e94148b94569982fdff3d2.pdf?sfvrsn=6b78d1d6_2

Take responsibility to obtain this information and comply with all requirements posted on this website up through five calendar days before the opening of bids.

Comply with the provisions contained in FHWA-1273.

If the Department's website cannot be accessed, contact the Department's Specifications Office Web Coordinator at (850) 414-4101.

7-1.4 Compliance with Federal Endangered Species Act and other Wildlife Regulations: The Federal Endangered Species Act requires that the Department investigate the potential impact to a threatened or endangered species prior to initiating an activity performed in

conjunction with a highway construction project. If the Department's investigation determines that there is a potential impact to a protected, threatened or an endangered species, the Department will conduct an evaluation to determine what measures may be necessary to mitigate such impact. When mitigation measures and/or special conditions are necessary, these measures and conditions will be addressed in the Contract Documents or permits.

In addition, in cases where certain protected, threatened or endangered species are found or appear within close proximity to the project boundaries, the Department has established guidelines that will apply when interaction with certain species occurs, absent of any special mitigation measures or permit conditions otherwise identified for the project.

These guidelines are posted at the following URL address:https://fdotwww.blob.core.windows.net/sitefinity/docs/default-source/programmanagement/implemented/urlinspecs/files/endangeredwildlifeguidelines.pdf?sfvrsn=e27baf3f_2.

Take responsibility to obtain this information and take all actions and precautions necessary to comply with the conditions of these guidelines during all project activities.

Prior to establishing any off-project activity in conjunction with a project, notify the Engineer of the proposed activity. Covered activities include but are not necessarily limited to borrow pits, concrete or asphalt plant sites, disposal sites, field offices, and material or equipment storage sites. Include in the notification the Financial Project ID, a description of the activity, the location of the site by township, range, section, county, and city, a site location map including the access route, the name of the property owner, and a person to contact to arrange a site inspection. Submit this notification at least 30 days in advance of planned commencement of the off-site activity, to allow for the Department to conduct an investigation without delaying job progress.

Do not perform any off-project activity without obtaining written clearance from the Engineer. In the event the Department's investigation determines a potential impact to a protected, threatened or endangered species and mitigation measures or permits are necessary, coordinate with the appropriate resource agencies for clearance, obtain permits and perform mitigation measures as necessary. Immediately notify the Engineer in writing of the results of this coordination with the appropriate resource agencies. Additional compensation or time will not be allowed for permitting or mitigation, associated with Contractor initiated off-project activities.

7-1.8 Compliance with Section 4(f) of the USDOT Act: Section 4(f) of the USDOT Act prohibits the U. S. Secretary of Transportation from approving a project which requires the use of publicly owned land of a public park, recreation area or a wildlife and waterfowl refuge, or of any historic site of national, state, or local significance unless there is no prudent or feasible alternative to using that land and the program or project includes all possible planning to minimize the harm to the site resulting from the use.

Before undertaking any off-project activity associated with any federally assisted undertaking, ensure that the proposed site does not represent a public park, recreation area, wildlife or waterfowl refuge, or a historic site (according to the results of the Cultural Resources Survey discussed in 120-6.2). If such a site is proposed, notify the Engineer and provide a description of the proposed off-site activity, the Financial Project ID, the location of the site by township, range, section, a county or city map showing the site location, including the access route and the name of the property. It is the Contractor's responsibility to submit justification for use of Section 4(f) property that is sufficient for the Florida Department of Transportation and the Federal Highway Administration to make a Section 4(f) determination. Submit this notification sufficiently in advance of planned commencement of the off-site activity to allow a reasonable time for the

Engineer to conduct an investigation without delaying job progress. Do not begin any off-project activity without obtaining written clearance from the Engineer.

7-16 Wage Rates for Federal-Aid Projects.

For this Contract, payment of predetermined minimum wages applies.

The U.S. Department of Labor (USDOL) Wage Rates applicable to this Contract are listed in table below, as modified up through ten days prior to the opening of bids.

Wage Rate Decision Number	Associated Work
FL20210193	Highway

Obtain the applicable General Decision(s) (Wage Tables) through the Department’s Office of Construction website and ensure that employees receive the minimum compensation applicable. Review the General Decisions for all classifications necessary to complete the project. Request additional classifications through the Engineer’s office when needed.

7-24 Disadvantaged Business Enterprise Program.

~~7-24.1 Disadvantaged Business Enterprise Affirmative Action Plan: Prior to award of the Contract, have an approved Disadvantaged Business Enterprise (DBE) Affirmative Action Program Plan filed with the Equal Opportunity Office. Update and resubmit the plan every three years. No Contract will be awarded until the Department approves the Plan. The DBE Affirmative Action Program Plan is incorporated into and made a part of the Contract.~~

7-24.2 Required Contract and Subcontract DBE Assurance Language: In accordance with 49 CFR 26.13 (b), the Contract FDOT signs with the Contractor (and each subcontract the prime contractor signs with a subcontractor) must include the following assurance: “The Contractor, sub-recipient or subcontractor shall not discriminate on the basis of race, color, national origin, or sex in the performance of this contract. The Contractor shall carry out applicable requirements of 49 CFR Part 26 in the award and administration of DOT-assisted Contracts. Failure by the Contractor to carry out these requirements is a material breach of this Contract, which may result in the termination of this Contract or such other remedy as the recipient deems appropriate, which may include, but is not limited to,

1. Withholding monthly progress payments;
2. Assessing sanctions;
3. Liquidated damages; and/or
4. Disqualifying the Contractor from future bidding as non-responsible.”

~~7-24.3 Plan Requirements: Include the following in the DBE Affirmative Action Program Plan:~~

~~1. A policy statement, signed by an authorized representative (president, chief executive officer, or chairman of the contractor), expressing a commitment to use DBEs in all aspects of contracting to the maximum extent feasible, outlining the various levels of responsibility, and stating the objectives of the program. Circulate the policy statement throughout the Contractor’s organization.~~

~~2. The designation of a Liaison Officer within the Contractor’s organization, as well as support staff, necessary and proper to administer the program, and a description of the authority,~~

NASSAU COUNTY INVITATION TO BID
NC21-014-ITB - CR-121, S. 14TH ST., CHESTER RD., SADLER RD., & AMELIA CONCOURSE

~~responsibility, and duties of the Liaison Officer and support staff. The Liaison Officer and staff are responsible for developing, managing, and implementing the program on a day-to-day basis for carrying out technical assistance activities for DBEs and for disseminating information on available business opportunities so that DBEs are provided an equitable opportunity to participate in Contracts let by the Department.~~

~~3. Utilization of techniques to facilitate DBE participation in contracting activities which include, but are not limited to:~~

~~a. Soliciting price quotations and arranging a time for the review of Plans, quantities, specifications, and delivery schedules, and for the preparation and presentation of quotations.~~

~~b. Providing assistance to DBEs in overcoming barriers such as the inability to obtain bonding, financing, or technical assistance.~~

~~c. Carrying out information and communication programs or workshops on contracting procedures and specific contracting opportunities in a timely manner, with such programs being bilingual where appropriate.~~

~~d. Encouraging eligible DBEs to apply for certification with the Department.~~

~~e. Contacting Minority Contractor Associations and city and county agencies with programs for disadvantaged individuals for assistance in recruiting and encouraging eligible DBE contractors to apply for certification with the Department.~~

7-24.4 DBE Records and Reports: Submit the following through the Equal Opportunity Compliance System:

1. DBE Commitments - at or before the Pre-Construction Conference.

2. Report monthly, through the Equal Opportunity Compliance System on the Department's Website, actual payments (including retainage) made to DBEs for work performed with their own workforce and equipment in the area in which they are certified. Report payments made to all DBE and Minority Business Enterprise (MBE) subcontractors and DBE and MBE construction material and major suppliers.

The Equal Opportunity Office will provide instructions on accessing this system. Develop a record keeping system to monitor DBE affirmative action efforts which include the following:

1. the procedures adopted to comply with these Specifications;

2. the number of subordinated Contracts on Department projects awarded to DBEs;

3. the dollar value of the Contracts awarded to DBEs;

4. the percentage of the dollar value of all subordinated Contracts awarded to DBEs as a percentage of the total Contract amount;

5. a description of the general categories of Contracts awarded to DBEs;

and

6. the specific efforts employed to identify and award Contracts to DBEs.

Upon request, provide the records to the Department for review.

Maintain all such records for a period of five years following acceptance of final payment and have them available for inspection by the Department and the Federal Highway Administration.

7-24.5 Counting DBE Participation and Commercially Useful Functions: 49 CFR Part 26.55 specifies when DBE credit shall be awarded for work performed by a DBE.

NASSAU COUNTY INVITATION TO BID

NC21-014-ITB - CR-121, S. 14TH ST., CHESTER RD., SADLER RD., & AMELIA CONCOURSE

DBE credit can only be awarded for work actually performed by DBEs themselves for the types of work for which they are certified. When reporting DBE Commitments, only include the dollars that a DBE is expected to earn for work they perform with their own workforce and equipment. Update DBE Commitments to reflect changes to the initial amount that was previously reported or to add DBEs not initially reported.

When a DBE participates in a contract, the value of the work is determined in accordance with 49 CFR Part 26.55, for example:

1. The Department will count only the value of the work performed by the DBE toward DBE goals. The entire amount of the contract that is performed by the DBE's own forces (including the cost of supplies, equipment and materials obtained by the DBE for the contract work) will be counted as DBE credit.

2. The Department will count the entire amount of fees or commissions charged by the DBE firm for providing a bona fide service, such as professional, technical, consultant, or managerial services or for providing bonds or insurance specifically required for the performance of a Department-assisted contract, toward DBE goals, provided that the Department determines the fees to be reasonable and not excessive as compared with fees customarily followed for similar services.

3. When the DBE subcontracts part of the work of its contract to another firm, the Department will count the value of the subcontracted work only if the DBE's subcontractor is itself a DBE. Work that a DBE subcontracts to a non-DBE firm does not count toward DBE goals.

4. When a DBE performs as a participant in a joint venture, the Department will count the portion of the dollar value of the contract equal to the distinct, clearly defined portion of the work the DBE performs with its own forces toward DBE goals.

5. The Contractors shall ensure that only expenditures to DBEs that perform a commercially useful function (CUF) in the work of a contract may be counted toward the voluntary DBE goal.

6. A DBE performs a commercially useful function when it is responsible for execution of the work of the contract and is carrying out its responsibilities by actually performing, managing, and supervising the work involved. To perform a commercially useful function, the DBE must also be responsible, with respect to materials and supplies used on the contract, for negotiating price, determining quality and quantity, ordering the material, and installing (where applicable) and paying for the material itself.

7. Contractors wishing to use joint checks involving DBE credit must provide written notice to the District Contract Compliance Office prior to issuance of the joint check. The Contractor must also provide a copy of the notice to the DBE subcontractor and maintain a copy with the project records.

8. To determine whether a DBE is performing a commercially useful function, the Department will evaluate the amount of work subcontracted, industry practices, whether the amount the firm is to be paid under the contract is commensurate with the work it is actually performing and the DBE credit claimed for its performance of the work, and other relevant factors.

9. A DBE does not perform a commercially useful function if its role is limited to that of an extra participant in a transaction, contract, or project through which funds are passed in order to obtain the appearance of DBE participation.

10. If a DBE does not perform or exercise responsibility for at least 30% of

the total cost of its contract with its own workforce, or if the DBE subcontracts a greater portion of the work of a contract than would be expected on the basis of normal industry practice for the type of work involved, the DBE has not performed a commercially useful function.

7-24.6 Prompt Payments: Meet the requirements of 9-5 for payments to all DBE subcontractors.

7-25 On-The-Job Training Requirements.

As part of the Contractor's equal employment opportunity affirmative action program, training shall be provided as follows:

The Contractor shall provide On-The-Job Training aimed at developing full journeymen in the type of trade or job classification involved in the work. In the event the Contractor subcontracts a portion of the contract work, it shall determine how many, if any, of the trainees are to be trained by the subcontractor provided, that the Contractor shall retain the primary responsibility for meeting the training requirements imposed by this Section. Ensure that, when feasible, 25% of trainees in each occupation are in their first year of training. The Contractor shall incorporate the requirements of this Section into such subcontract.

The number of trainees will be estimated on the number of calendar days of the contract, the dollar value, and the scope of work to be performed. The trainee goal will be finalized at a Post-Preconstruction Trainee Evaluation Meeting and the goal will be distributed among the work classifications based on the following criteria:

1. Determine the number of trainees on Federal Aid Contract:

a. No trainees will be required for contracts with a Contract Time allowance of less than 275 calendar days.

b. If the Contract Time allowance is 275 calendar days or more, the number of trainees shall be established in accordance with the following chart:

Estimated Contract Amount	Trainees Required
\$2,000,000 or less	0
Over \$2,000,000 to \$4,000,000	2
Over \$4,000,000 to \$6,000,000	3
Over \$6,000,000 to \$12,000,000	5
Over \$12,000,000 to \$18,000,000	7
Over \$18,000,000 to \$24,000,000	9
Over \$24,000,000 to \$31,000,000	12
Over \$31,000,000 to \$37,000,000	13
Over \$37,000,000 to \$43,000,000	14
Over \$43,000,000 to \$49,000,000	15
Over \$49,000,000 to \$55,000,000	16
Over \$55,000,000 to \$62,000,000	17
Over \$62,000,000 to \$68,000,000	18
Over \$68,000,000 to \$74,000,000	19
Over \$74,000,000 to \$81,000,000	20
Over \$81,000,000 to \$87,000,000	21
Over \$87,000,000 to \$93,000,000	22
Over \$93,000,000 to \$99,000,000	23

NASSAU COUNTY INVITATION TO BID

NC21-014-ITB - CR-121, S. 14TH ST., CHESTER RD., SADLER RD., & AMELIA CONCOURSE

Estimated Contract Amount	Trainees Required
Over \$99,000,000 to \$105,000,000	24
Over \$105,000,000 to \$112,000,000	25
Over \$112,000,000 to \$118,000,000	26
Over \$118,000,000 to \$124,000,000	27
Over \$124,000,000 to \$130,000,000	28
Over \$130,000,000 to *	
*One additional trainee per \$6,000,000 of estimated Construction Contract amount over \$130,000,000	

Further, if the Contractor or subcontractor requests to utilize banked trainees as discussed later in this Section, a Banking Certificate will be validated at this meeting allowing credit to the Contractor for previously banked trainees. Banked credits of prime Contractors working as Subcontractors may be accepted for credit. The Contractor's Project Manager, the Construction Project Engineer and the Department's District Contract Compliance Manager will attend this meeting. Within ten days after the Post-Preconstruction Training Evaluation Meeting, the Contractor shall submit to the Department for approval an On-The-Job Training Schedule indicating the number of trainees to be trained in each selected classification and the portion of the Contract Time during which training of each trainee is to take place. This schedule may be subject to change if any of the following occur:

1. When a start date on the approved On-The-Job Training Schedule has been missed by 14 or more days;
2. When there is a change in previously approved classifications;
3. When replacement trainees are added due to voluntary or involuntary termination

The revised schedule will be resubmitted to and approved by the Department's District Contract Compliance Manager.

The following criteria will be used in determining whether or not the Contractor has complied with this Section as it relates to the number of trainees to be trained:

1. Credit will be allowed for each trainee that is both enrolled and satisfactorily completes training on this Contract. Credit for trainees, over the established number for this Contract, will be carried in a "bank" for the Contractor and credit will be allowed for those surplus trainees in subsequent, applicable projects. A "banked" trainee is described as an employee who has been trained on a project, over and above the established goal, and for which the Contractor desires to preserve credit for utilization on a subsequent project.

2. Credit will be allowed for each trainee that has been previously enrolled in the Department's approved training program on another contract and continues training in the same job classification and completes their training on a different contract.

3. Credit will be allowed for each trainee who, due to the amount of work available in their classification, is given the greatest practical amount of training on the contract regardless of whether or not the trainee completes training.

4. Credit will be allowed for any training position indicated in the approved On-The-Job Training Schedule, if the Contractor can demonstrate that made a good faith effort to provide training in that classification was made.

5. No credit will be allowed for a trainee whose employment by the Contractor is involuntarily terminated unless the Contractor can clearly demonstrate good cause for this action.

Training and upgrading of minorities, women and economically disadvantaged persons toward journeyman status is a primary objective of this Section. Accordingly, the Contractor shall

make every effort to enroll minority trainees and women (e.g., by conducting systematic and direct recruitment through public and private sources likely to yield minority and women trainees) to the extent such persons are available within a reasonable area of recruitment. If a non-minority male is enrolled into the On-The-Job Training Program, the On-The-Job Training Notification of Personnel Action Form notifying the District Contract Compliance Manager of such action shall be accompanied by a disadvantaged certification or a justification for such action acceptable to the Department's District Contract Compliance Manager. The Contractor will be given an opportunity and will be responsible for demonstrating the steps that it has taken in pursuance thereof, prior to a determination as to whether the Contractor is in compliance with this Section. This training is not intended, and shall not be used, to discriminate against any applicant for training, whether a minority, woman or disadvantaged person.

No employee shall be employed as a trainee in any classification in which they have successfully completed a training course leading to journeyman status, or have been employed as a journeyman. The Contractor may satisfy this requirement by including appropriate questions in the employee application or by other suitable means. Regardless of the method used, the Contractor's records should document the findings in each case.

The minimum length and type of training for each classification will be as established at the Post-Preconstruction Trainee Evaluation Meeting and approved by the Department. Graduation to journeyman status will be based upon satisfactory completion of a Proficiency Demonstration set up at the completion of training and established for the specific training classification, completion of the minimum hours in a training classification range, and the employer's satisfaction that the trainee does meet journeyman status in the classification of training. Upon reaching journeyman status, the following documentation must be forwarded to the District Contract Compliance Office:

1. Trainee Enrollment and Personnel Action Form
2. Proficiency Demonstration Verification Form indicating completion of each standard established for the classification signed by representatives of both the Contractor and the Department.

The Department and the Contractor shall establish a program that is tied to the scope of the work in the project and the length of operations providing it is reasonably calculated to meet the equal employment opportunity obligations of the Contractor and to qualify the average trainee for journeyman status in the classifications concerned, by at least, the minimum hours prescribed for a training classification. Furthermore, apprenticeship programs registered with the U.S. Department of Labor, Bureau of Apprenticeship and Training, or with a State apprenticeship agency recognized by the Bureau and training programs approved but not necessarily sponsored by the U.S. Department of Labor, Manpower Administration, Bureau of Apprenticeship and Training shall also be considered acceptable provided it is being administered in a manner consistent with the equal employment obligations of Federal Aid highway construction contract. Approval or acceptance of a training schedule shall be obtained from the Department prior to commencing work on the classifications covered by the program.

A voluntary On-The-Job Training Program is available to a Contractor which has been awarded a state funded project. Through this program, the Contractor will have the option to train employees on state funded projects for "banked credit" as discussed previously in this provision, to be utilized on subsequent Federal Aid Projects where training is required. Those Contractors availing themselves of this opportunity to train personnel on state funded projects and bank trainee hours for credit shall comply with all training criteria set forth in this Section for Federal Aid

Projects; voluntary banking may be denied by the Department if staff is not available to monitor compliance with the training criteria.

It is the intention of these provisions that training is to be provided in the construction crafts rather than clerk-typists or secretarial type positions. Training is permissible in lower level management positions such as office engineers, estimators, etc., where the training is oriented toward construction applications. Training in the laborer classifications, except Common/General Laborer, may be permitted provided that significant and meaningful training is provided and approved by the District Contract Compliance Office.

When approved in advance by the District Contract Compliance Manager, credit will be given for training of persons in excess of the number specified herein under the current contract or a Contractor will be allowed to bank trainees who have successfully completed a training program and may apply those trainees to a training requirement in subsequent project(s) upon approval of the Department's District Contract Compliance Manager. This credit will be given even though the Contractor may receive training program funds from other sources, provided such other source do not specifically prohibit the Contractor from receiving other form of compensation. Offsite training is permissible as long as the training is an integral part of an approved training program and does not compromise a significant part of the overall training. Credit for offsite training indicated above may only be made to the Contractor when it does one or more of the following and the trainees are concurrently employed on a Federal Aid Project:

1. Contributes to the cost of the training,
2. Provides the instruction to the trainee,
3. Pays the trainee's wages during the offsite training period.

The Contractor shall compensate the trainee at no less than the laborer rate established in the Contract at the onset of training. The compensation rate will be increased to the journeyman's wage upon graduation from the training program for the remainder of the time the trainee works in the classification in which they were trained.

The Contractor shall furnish the trainee a copy of the program they will follow in providing the training. The Contractor shall provide each trainee with a certification showing the type and length of training satisfactorily completed. The Contractor shall enroll a trainee in one training classification at a time to completion before the trainee can be enrolled in another classification on the same project.

The Contractor shall maintain records to document the actual hours each trainee is engaged in training on work being performed as a part of this Contract.

The Contractor shall submit to the District Contract Compliance Manager a copy of an On-The-Job Training Notification of Personnel Action form no later than seven days after the effective date of the action when the following actions occur: a trainee is transferred on the project, transferred from the project to continue training on another contract, completes training, is upgraded to journeyman status or voluntary terminates or is involuntary terminated from the project.

The Contractor shall furnish to the District Contract Compliance Manager a copy of a Monthly Time Report for each trainee. The Monthly Time Report for each month shall be submitted no later than the tenth day of the subsequent month. The Monthly Time Report shall indicate the phases and sub-phases of the number of hours devoted to each proficiency.

Highway or Bridge Carpenter Helper, Mechanic Helper, Rodman/Chainman, and Timekeeper classifications will not be approved for the On-The-Job Training Program.

NASSAU COUNTY INVITATION TO BID
NC21-014-ITB - CR-121, S. 14TH ST., CHESTER RD., SADLER RD., & AMELIA CONCOURSE

The number of trainees may be distributed among the work classifications on the basis of the Contractor's needs and the availability of journeymen in the various classifications within a reasonable area of recruitment.

The Contractor will have fulfilled the responsibilities of this Specification when acceptable training has been provided to the trainee as specified above.

7-26 Cargo Preference Act – Use of United States-Flag Vessels.

Pursuant to Title 46 CFR 381, the Contractor agrees

1. To utilize privately owned United States-flag commercial vessels to ship at least 50 percent of the gross tonnage (computed separately for dry bulk carriers, dry cargo liners, and tankers) involved, whenever shipping any equipment, material, or commodities pursuant to this Contract, to the extent such vessels are available at fair and reasonable rates for United States-flag commercial vessels.

2. To furnish within 20 days following the date of loading for shipments originating within the United States or within 30 working days following the date of loading for shipments originating outside the United States, a legible copy of a rated, 'on-board' commercial ocean bill-of-lading in English for each shipment of cargo described in paragraph 1 of this Article to both the Contracting Officer (through the prime contractor in the case of subcontractor bills-of-lading) and to the Division of National Cargo, Office of Market Development, Maritime Administration, Washington, DC 20590.

3. To insert the substance of the provisions of this clause in all subcontracts issued pursuant to this Contract.

7-29 E-Verify.

The Contractor shall utilize the U.S. Department of Homeland Security's E-Verify system to verify the employment eligibility of all new employees hired by the Contractor during the term of the Contract and shall expressly require any subcontractors performing work or providing services pursuant to the Contract to likewise utilize the U.S. Department of Homeland Security's E-Verify system to verify the employment eligibility of all new employees hired by the subcontractor during the Contract term.

7-31 Title VI Assurance – DOT 1050.2A, Appendix A and Appendix E.

7-31.1 Appendix A: During the performance of this Contract, the Contractor, for itself, its assignees and successors in interest (hereinafter referred to as the "Contractor") agrees as follows:

1. Compliance with Regulations: The Contractor shall comply with the Regulations relative to nondiscrimination in Federally-assisted programs of the US Department of Transportation (hereinafter, "USDOT") Title 49, Code of Federal Regulations, Part 21, as they may be amended from time to time, (hereinafter referred to as the Regulations), which are herein incorporated by reference and made a part of this Contract.

2. Nondiscrimination: The Contractor, with regard to the work performed by it during the Contract, shall not discriminate on the basis of race, color, national origin or sex in the selection and retention of sub-contractors, including procurements of materials and leases of equipment. The Contractor shall not participate either directly or indirectly in the discrimination prohibited by Section 21.5 of the Regulations, including employment practices when the Contract covers a program set forth in Appendix B of the Regulations.

3. Solicitations for subcontractors, including procurements of materials and equipment: In all solicitations either by competitive bidding or negotiation made by the Contractor

for work to be performed under subcontract, including procurements of materials or leases of equipment, each potential subcontractor or supplier shall be notified by the Contractor of the Contractor's obligations under this contract and the Regulations relative to nondiscrimination on the basis of race, color, national origin, or sex.

4. Information and Reports: The Contractor shall provide all information and reports required by the Regulations or directives issued pursuant thereto, and shall permit access to its books, records, accounts, other sources of information and its facilities as may be determined by the Florida Department of Transportation or the Federal Highway Administration, Federal Transit Administration, Federal Aviation Administration, and Federal Motor Carrier Safety Administration to be pertinent to ascertain compliance with such Regulations, order and instructions. Where any information required of a Contractor is in the exclusive possession of another who fails or refuses to furnish this information the Contractor shall so certify to the Florida Department of Transportation, or the Federal Highway Administration, Federal Transit Administration, Federal Aviation Administration, or Federal Motor Carrier Safety Administration as appropriate, and shall set forth what efforts it has made to obtain the information.

5. Sanctions for Noncompliance: In the event of the Contractor's noncompliance with the nondiscrimination provisions of this Contract, the Florida Department of Transportation shall impose such Contract sanctions as it or the Federal Highway Administration, Federal Transit Administration, Federal Aviation Administration, or Federal Motor Carrier Safety Administration may determine to be appropriate, including, but not limited to:

- a. withholding of payments to the Contractor under the Contract until the Contractor complies, or
- b. cancellation, termination or suspension of the Contract, in whole or in part.

6. Incorporation of Provisions: The Contractor shall include the provisions of this appendix in every subcontract, including procurements of materials and leases of equipment, unless exempt by the Regulations, or directives issued pursuant thereto. The Contractor shall take such action with respect to any subcontract or procurement as the Florida Department of Transportation or the Federal Highway Administration, Federal Transit Administration, Federal Aviation Administration, or Federal Motor Carrier Safety Administration may direct as a means of enforcing such provisions including sanctions for noncompliance, provided, however, that, in the event a Contractor becomes involved in, or is threatened with, litigation with a subcontractor or supplier as a result of such direction, the Contractor may request the Florida Department of Transportation to enter into such litigation to protect the interests of the Florida Department of Transportation, and, in addition, the Contractor may request the United States to enter into such litigation to protect the interests of the United States.

7-31.2 Appendix E: During the performance of this Contract, the Contractor, for itself, its assignees, and successors in interest (hereinafter referred to as the "Contractor" agrees to comply with the following non-discrimination statutes and authorities; including but not limited to:

1. Title VI of the Civil Rights Act of 1964 (42 U.S.C. § 2000d et seq., 78 stat. 252), (prohibits discrimination on the basis of race, color, national origin); and 49 CFR Part 21;
2. The Uniform Relocation Assistance and Real Property Acquisition Policies Act of 1970, (42 U.S.C. § 4601), (prohibits unfair treatment of persons displaced or whose property has been acquired of Federal or Federal-aid programs and projects);
3. Federal-Aid Highway Act of 1973, (23 U.S.C § 324 et seq.), (prohibits discrimination on the basis of sex);

NASSAU COUNTY INVITATION TO BID
NC21-014-ITB - CR-121, S. 14TH ST., CHESTER RD., SADLER RD., & AMELIA CONCOURSE

4. Section 504 of the Rehabilitation Act of 1973 (29 U.S.C. § 794 et seq.), as amended, (prohibits discrimination on the basis of disability); and 49 CFR Part 27;

5. The Age Discrimination Act of 1975, as amended, (42 U.S.C. § 6101 et seq.), (prohibits discrimination on the basis of age);

6. Airport and Airway Improvement Act of 1982, (49 U.S.C. 471, Section 47123), as amended, (prohibits discrimination based on race, creed, color national origins or sex);

7. The Civil Rights Restoration Act of 1987 (PL 100-209), (Broadened the scope, coverage and applicability of Title VI of the Civil Rights Act of 1964, The Age Discrimination Act of 1975 and Section 504 of the Rehabilitation Act of 1973, by expanding the definition of the terms “programs or activities” to include all of the programs or activities of the Federal-aid recipients, sub-recipients and contractors, whether such programs or activities are Federally funded or not);

8. Titles II and III of the Americans with Disabilities Act, which prohibits discrimination on the basis of disability in the operation of public entities, public and private transportation systems, places of public accommodation, and certain testing entities (42 U.S.C. §§ 12131 – 12189) as implemented by Department of Transportation regulations at 49 C.F.R. parts 37 and 38;

9. The Federal Aviation Administration’s Non-discrimination statute (49 U.S.C. § 47123) (prohibits discrimination on the basis of race, color, national origin, and sex);

10. Executive Order 12898, Federal Actions to Address Environmental Justice in Minority Populations and Low-Income Populations, which ensures non-discrimination against minority populations by discouraging programs, policies, and activities with disproportionately high and adverse human health or environmental effects on minority and low-income populations;

11. Executive Order 13166, Improving Access to Services for Persons with Limited English Proficiency, and resulting agency guidance, national origin discrimination includes discrimination because of limited English proficiency (LEP). To ensure compliance with Title VI, you must take reasonable steps to ensure that LEP persons have meaningful access to your programs (70 Fed. Reg. at 74087 to 74100);

12. Title IX of the Education Amendments of 1972, as amended, which prohibits discrimination based on sex in education programs, or activities (20 U.S.C. 1681 et seq.).

FROM SECTION 8 (SUBLETTING, CONTRACT TIME EXTENSION, AND LIQUIDATED DAMAGES).

8-1 Subletting or Assigning of Contracts.

Do not, sell, transfer, assign or otherwise dispose of the Contract or Contracts or any portion thereof, or of the right, title, or interest therein, without written consent of the Department. If the Contractor chooses to sublet any portion of the Contract, the Contractor must provide a written request to sublet work on the Certification of Sublet Work form developed by the Department for this purpose. With the Engineer’s acceptance of the request, the Contractor may sublet a portion of the work, but shall perform with its own organization work amounting to not less than 40% of the total Contract amount. The Certification of Sublet Work request will be deemed acceptable by the Department, for purposes of the Department’s consent, unless the Engineer notifies the Contractor within 5 business days of receipt of the Certification of Sublet Work that the Department is not consenting to the requested subletting.

Include in the total Contract amount the cost of materials and manufactured component products, and their transportation to the project site. For the purpose of meeting this requirement

NASSAU COUNTY INVITATION TO BID
NC21-014-ITB - CR-121, S. 14TH ST., CHESTER RD., SADLER RD., & AMELIA CONCOURSE

the Department will not consider off-site commercial production of materials and manufactured component products that the Contractor purchases, or their transportation to the project, as subcontracted work.

If the Contractor sublets a part of a Contract item, the Department will use only the sublet proportional cost in determining the percentage of subcontracted normal work.

Execute all agreements to sublet work in writing and include all pertinent provisions and requirements of the Contract. All other agreements must be in writing and reference all applicable Contract provisions. Upon request, furnish the Department with a copy of the subcontract and agreement. The subletting of work does not relieve the Contractor or the surety of their respective liabilities under the Contract.

The Department recognizes a subcontractor only in the capacity of an employee or agent of the Contractor, and the Engineer may require the Contractor to remove the subcontractor as in the case of an employee.

8-7.3.2 Contract Time Extensions: The Department may grant an extension of Contract Time when a controlling item of work is delayed by factors not reasonably anticipated or foreseeable at the time of bid. The Department may allow such extension of time only for delays occurring during the Contract Time period or authorized extensions of the Contract Time period. When failure by the Department to fulfill an obligation under the Contract results in delays to the controlling items of work, the Department will consider such delays as a basis for granting a time extension to the Contract.

Whenever the Engineer suspends the Contractor's operations, as provided in 8-6, for reasons other than the fault of the Contractor, the Engineer will grant a time extension for any delay to a controlling item of work due to such suspension. The Department will not grant time extensions to the Contract for delays due to the fault or negligence of the Contractor.

The Department does not include an allowance for delays caused by the effects of inclement weather or suspension of Contractor's operations in establishing Contract Time. The Engineer will continually monitor the effects of weather and, when found justified, grant time extensions on either a bimonthly or monthly basis. The Engineer will not require the Contractor to submit a request for additional time due to the effects of weather.

The Department will grant time extensions, on a day for day basis, for delays caused by the effects of rains or other inclement weather conditions, related adverse soil conditions or suspension of operations that prevent the Contractor from productively performing controlling items of work resulting in:

1. The Contractor being unable to work at least 50% of the normal work day on pre-determined controlling work items; or
2. The Contractor must make major repairs to work damaged by weather, provided that the damage is not attributable to the Contractor's failure to perform or neglect; and provided that the Contractor was unable to work at least 50% of the normal workday on pre-determined controlling work items.

No additional compensation will be made for delays caused by the effects of inclement weather.

The Department will consider the delays in delivery of materials or component equipment that affect progress on a controlling item of work as a basis for granting a time extension if such delays are beyond the control of the Contractor or supplier. Such delays may include an area-wide shortage, an industry-wide strike, or a natural disaster that affects all feasible sources of supply. In such cases, the Contractor shall furnish substantiating letters from a

NASSAU COUNTY INVITATION TO BID

NC21-014-ITB - CR-121, S. 14TH ST., CHESTER RD., SADLER RD., & AMELIA CONCOURSE

representative number of manufacturers of such materials or equipment clearly confirming that the delays in delivery were the result of an area-wide shortage, an industry-wide strike, etc. No additional compensation will be made for delays caused by delivery of materials or component equipment.

The Department will not consider requests for time extension due to delay in the delivery of custom manufactured equipment such as traffic signal equipment, highway lighting equipment, etc., unless the Contractor furnishes documentation that he placed the order for such equipment in a timely manner, the delay was caused by factors beyond the manufacturer's control, and the lack of such equipment caused a delay in progress on a controlling item of work. No additional compensation will be paid for delays caused by delivery of custom manufactured equipment.

The Department will consider the affect of utility relocation and adjustment work on job progress as the basis for granting a time extension only if all the following criteria are met:

1. Delays are the result of either utility work that was not detailed in the Plans, or utility work that was detailed in the Plans but was not accomplished in reasonably close accordance with the schedule included in the Contract Documents.
2. Utility work actually affected progress toward completion of controlling work items.
3. The Contractor took all reasonable measures to minimize the effect of utility work on job progress, including cooperative scheduling of the Contractor's operations with the scheduled utility work at the preconstruction conference and providing adequate advance notification to utility companies as to the dates to coordinate their operations with the Contractor's operations to avoid delays.

As a condition precedent to an extension of Contract Time the Contractor must submit to the Engineer:

A preliminary request for an extension of Contract Time must be made in writing to the Engineer within ten calendar days after the commencement of a delay to a controlling item of work. If the Contractor fails to submit this required preliminary request for an extension of Contract Time, the Contractor fully, completely, absolutely and irrevocably waives any entitlement to an extension of Contract Time for that delay. In the case of a continuing delay only a single preliminary request for an extension of Contract Time will be required. Each such preliminary request for an extension of Contract Time shall include as a minimum the commencement date of the delay, the cause of the delay, and the controlling item of work affected by the delay.

Furthermore, the Contractor must submit to the Engineer a request for a Contract Time extension in writing within 30 days after the elimination of the delay to the controlling item of work identified in the preliminary request for an extension of Contract Time. Each request for a Contract Time extension shall include as a minimum all documentation that the Contractor wishes the Department to consider related to the delay, and the exact number of days requested to be added to Contract Time. If the Contractor contends that the delay is compensable, then the Contractor shall also be required to submit with the request for a Contract Time extension a detailed cost analysis of the requested additional compensation. If the Contractor fails to submit this required request for a Contract Time extension, with or without a detailed cost analysis, depriving the Engineer of the timely opportunity to verify the delay and the costs of the delay, the

Contractor waives any entitlement to an extension of Contract Time or additional compensation for the delay.

Upon timely receipt of the preliminary request of Contract Time from the Contractor, the Engineer will investigate the conditions, and if it is determined that a controlling item of work is being delayed for reasons beyond the control of the Contractor the Engineer will take appropriate action to mitigate the delay and the costs of the delay. Upon timely receipt of the request for a Contract Time extension the Engineer will further investigate the conditions, and if it is determined that there was an increase in the time or the cost of performance of the controlling item of work beyond the control of the Contractor, then an adjustment of Contract Time will be made, and a monetary adjustment will be made, excluding loss of anticipated profits, and the Contract will be modified in writing accordingly.

The existence of an accepted schedule, including any required update(s), is a condition precedent to the Contractor having any right to the granting of an extension of Contract Time or any monetary compensation arising out of any delay. Contractor failure to have an accepted schedule, including any required update(s), for the period of potential impact, or in the event the currently accepted schedule and applicable updates do not accurately reflect the actual status of the project or fail to accurately show the true controlling or non-controlling work activities for the period of potential impact, will result in any entitlement determination as to time or money for such period of potential impact being limited solely to the Department’s analysis and identification of the actual controlling or non-controlling work activities. Further, in such instances, the Department’s determination as to entitlement as to either time or compensability will be final, unless the Contractor can prove by clear and convincing evidence to a Disputes Review Board that the Department’s determination was without any reasonable factual basis.

8-10 Liquidated Damages for Failure to Complete the Work.

8-10.2 Amount of Liquidated Damages: Applicable liquidated damages are the amounts established in the following schedule:

Original Contract Amount	Daily Charge Per Calendar Day
\$50,000 and under.....	\$1,015
Over \$50,000 but less than \$250,000.....	\$1,045
\$250,000 but less than \$500,000.....	\$1,170
\$500,000 but less than \$2,500,000.....	\$1,690
\$2,500,000 but less than \$5,000,000.....	\$2,579
\$5,000,000 but less than \$10,000,000.....	\$3,756
\$10,000,000 but less than \$15,000,000.....	\$4,344
\$15,000,000 but less than \$20,000,000.....	\$5,574
\$20,000,000 and over.....	\$10,203 plus 0.00005 of any amount over \$20 million (Round to nearest whole dollar)

FROM SECTION 9 (PARTIAL PAYMENTS).

9-5 Partial Payments.

9-5.1 General: The Engineer will make partial payments on monthly estimates based on the amount of work that the Contractor completes during the month (including delivery of certain materials, as specified herein below). The Engineer will make approximate monthly payments,

and the Department will correct all partial estimates and payments in the subsequent estimates and in the final estimate and payment.

The Department will base the amount of such payments on the total value of the work that the Contractor has performed to the date of the estimate, based on the quantities completed and the Contract prices, less payments previously made and less any retainage withheld.

Retainage will not be withheld until the percent of Contract Time used exceeds 75%. ~~From that time forward, the Department will withhold retainage of 10% of the amount due on the current estimate as retainage when the percent of Contract Time used exceeds the percent of Contract amount earned by more than 15%.~~

Contract amount is defined as the original Contract amount adjusted by approved supplemental agreements.

Retainage will be determined for each job on multiple job Contracts. The Department will not accept Securities, Certificates of Deposit or letters of credit as a replacement for retainage. Amounts withheld will not be released until payment of the final estimate.

9-5.2 Unsatisfactory Payment Record: In accordance with Sections 255.05 and 337.16 of the Florida Statutes, and the rules of the Department, the Department may disqualify the Contractor from bidding on future Department contracts if the Contractor's payment record in connection with contract work becomes unsatisfactory.

9-5.3 Withholding Payment:

9-5.3.1 Withholding Payment for Defective Work: If the Department discovers any defective work or material prior to the final acceptance, or if the Department has a reasonable doubt as to the integrity of any part of the completed work prior to final acceptance, then the Department will not allow payment for such defective or questioned work until the Contractor has remedied the defect and removed any causes of doubt.

9-5.3.2 Withholding Payment for Failure to Comply: The Department will withhold progress payments from the Contractor if he fails to comply with any or all of the following within 60 days after beginning work:

1. comply with and submit required paperwork relating to prevailing wage rate provisions, Equal Employment Opportunity, On-The-Job Training, and Affirmative Action;
2. comply with the requirement to all necessary information, including actual payments to DBEs, all other subcontractors and major suppliers, through the Internet based Equal Opportunity Reporting System;
3. comply with or make a good faith effort to ensure employment opportunity for minorities and females in accordance with the required contract provisions for Federal Aid Construction Contracts, and
4. comply with or make a good faith effort to meet On-The-Job Training goals.

The Department will withhold progress payments until the Contractor has satisfied the above conditions.

9-5.4 Release of Retainage After Acceptance: When the Contractor has furnished the Department with all submittals required by the Contract, such as invoices, EEO reports, materials certifications, certification of materials procured, etc., (excluding Contractor's letter of acceptance of final amount due and Form 21-A release) and the Engineer has determined that the measurement and computation of pay quantities is correct, the Department may reduce the retainage to \$1,000 plus any amount that the Department elects to deduct for defective work as provided in 9-5.3.

NASSAU COUNTY INVITATION TO BID
NC21-014-ITB - CR-121, S. 14TH ST., CHESTER RD., SADLER RD., & AMELIA CONCOURSE

The Department may deduct from payment estimates any sums that the Contractor owes to the Department on any account. Where more than one project or job (separate job number) is included in the Contract, the Department will distribute the reduced retainage as provided in the first paragraph of this Subarticle to each separate project or job in the ratio that the Contract value of the work for the particular job bears to the total Contract amount.

9-5.5 Partial Payments for Delivery of Certain Materials:

9-5.5.1 General: The Department will allow partial payments for new materials that will be permanently incorporated into the project and are stockpiled in approved locations in the project vicinity. Stockpile materials so that they will not be damaged by the elements and in a manner that identifies the project on which they are to be used.

The following conditions apply to all payments for stockpiled materials:

1. There must be reasonable assurance that the stockpiled material will be incorporated into the specific project on which partial payment is made.

2. The stockpiled material must be approved as meeting applicable specifications.

3. The total quantity for which partial payment is made shall not exceed the estimated total quantity required to complete the project.

4. The Contractor shall furnish the Engineer with copies of certified invoices to document the value of the materials received. The amount of the partial payment will be determined from invoices for the material up to the unit price in the Contract.

5. Delivery charges for materials delivered to the jobsite will be included in partial payments if properly documented.

6. Partial payments will not be made for materials which were stockpiled prior to award of the Contract for a project.

9-5.5.2 Partial Payment Amounts: The following partial payment restrictions apply:

1. Partial payments less than \$5,000 for any one month will not be processed.

2. Partial payments for structural steel and precast prestressed items will not exceed 85% of the bid price for the item. Partial payments for all other items will not exceed 75% of the bid price of the item in which the material is to be used.

3. Partial payment will not be made for aggregate and base course material received after paving or base construction operations begin except when a construction sequence designated by the Department requires suspension of paving and base construction after the initial paving operations, partial payments will be reinstated until the paving and base construction resumes.

9-5.5.3 Off Site Storage: If the conditions of 9-5.5.1 are satisfied, partial payments will be allowed for materials stockpiled in approved in-state locations. Additionally, partial payments for materials stockpiled in approved out-of-state locations will be allowed if the conditions of 9-5.5.1 and the following conditions are met:

1. Furnish the Department a Materials Bond stating the supplier guarantees to furnish the material described in the Contract to the Contractor and Department. Under this bond, the Obligor shall be the material supplier and the Obligees shall be the Contractor and the Florida Department of Transportation. The bond shall be in the full dollar amount of the bid price for the materials described in the contract.

2. The following clauses must be added to the construction Contract between the Contractor and the supplier of the stockpiled materials:

“Notwithstanding anything to the contrary, <supplier> will be liable to the Contractor and the Florida Department of Transportation should <supplier> default in the performance of this agreement.”

“Notwithstanding anything to the contrary, this agreement, and the performance bond issued pursuant to this agreement, does not alter, modify, or otherwise change the Contractor’s obligation to furnish the materials described in this agreement to the Florida Department of Transportation.”

3. The agreement between the Contractor and the supplier of the stockpiled materials must include provisions that the supplier will store the materials and that such materials are the property of the Contractor.

9-5.6 Certification of Payment to Subcontractors: The term “subcontractor,” as used herein, includes persons or firms furnishing materials or equipment incorporated into the work or stockpiled for which the Department has made partial payment and firms working under equipment-rental agreements. The Contractor is required to pay all subcontractors for satisfactory performance of their Contracts before the Department will make a further progress (partial) payment. The Contractor shall also return all retainage withheld to the subcontractors within 30 days after the subcontractor’s work is satisfactorily complete, as determined by the Department. Prior to receipt of any progress (partial) payment, the prime contractor shall certify that all subcontractors having an interest in the Contract were paid for satisfactory performance of their Contracts and that the retainage is returned to subcontractors within 30 days after satisfactory completion of the subcontractor’s work. Provide this certification in the form designated by the Department.

Within 30 days of the Contractor’s receipt of the final progress payment or any other payments thereafter, except the final payment, the Contractor shall pay all subcontractors and suppliers having an interest in the Contract for all work completed and materials furnished. The Department will honor an exception to the above when the Contractor demonstrates good cause for not making any required payment and furnishes written notification of any such good cause to both the Department and the affected subcontractors or suppliers within said 30 day period.

The Contractor shall indemnify and provide defense for the Department when called upon to do so for all claims or suits against the Department, by third parties, pertaining to Contractor payment or performance issues arising out of the Contract. It is expressly understood that the monetary limitation on the extent of the indemnification shall be the approved Contract amount, which shall be the original Contract amount as may be increased by subsequent Supplemental Agreements.

**APPENDIX B-
NASSAU COUNTY POLICIES**



Nassau County Engineering Services Department
96161 Nassau Place
Yulee, Florida 32097

Road Closure Policy

1. Submit a written request to the Public Works Director for the road closure. In the request you must explain the following:
 - a) Why the road needs to be closed and the duration of the closure?
 - b) What are the benefits to public for closing the road?
 - c) Include a draft detour plan.

After the road closure request and draft detour plan have been approved, the following information shall be submitted to the Nassau County Engineering Services Department for review and approval.

2. Submit to Nassau County Engineering Services Department: A Maintenance of Traffic (MOT) Plan that was prepared by or approved by Florida Advanced Maintenance of Traffic (AMOT) certified personnel referencing the latest editions of the Florida Department of Transportation (FDOT) Design Standards Section 600 and the Manual on Uniform Traffic Control Devices (MUTCD). These plans shall include the Worksite Traffic Supervisor as per the latest edition of the FDOT Standard Specifications for Road & Bridge Construction Section 105-8.3. Variable Message Boards (VMB) will be required and shall be installed 7 days prior to the detour taking place and remain throughout. Any signed detour that will be within FDOT Right-of-Way (or on portions thereof) shall have prior FDOT approval.

A Maintenance of Traffic Plan proposing a change to any approved documents, including contract documents and approved construction plans must be signed and sealed.

3. Provide a public notification advertisement to an approved local newspaper. To appear no less than fourteen (14) days prior to the scheduled closure. Submit the draft notification to Nassau County Engineering Services for review and approval prior to advertising. This notification will clearly describe the name of the project and contractor, scope of the detour, scope of construction, the name of all roads that will be affected, official detour routes, duration of closure and the Worksite Traffic Supervisor's telephone number. Attach a diagram showing the surrounding area and detour routes. Diagram must be clear and depict road names and route direction. The size of advertisement in newspaper shall be a minimum of 2 columns wide by 12 inches long (tall) or one fifth (1/5) of a page with a minimum of 24 point font for the heading and 10 point font for the body and detour plan. Flyers with the same information may be required. With the Engineering Services Department's written approval, local roads may not require publishing of the advertisement in the paper; however, all other criteria must be adhered to.



Road Closure Policy

Page 2 of 3

4. Submit notification to the following departments and agencies prior to the road closure. A confirmation of notification to the Engineering Services Department must be provided prior to road closure.

- Nassau County Sheriff's Office:
 - o Ricky A Rowell, TAC
Phone -(904) 548-4000
Fax- (904) 225-5737
Email -rickyr@nassauso.com
 - o L. Rene Graham, Lt.
Phone -(904) 548-4028
Fax -(904) 548-4128
Email -lrgraham@nassauso.com
- Nassau County Emergency Management:
 - o Martha Oberdorfer
Phone -(904) 548-0931
Fax -(904) 548-4194
Email- mloberdorfer@nassauso.com
- Nassau County Fire Department:
 - o Scott Hemmingway and Asst. Chief
Phone -(904) 530-6600
Fax -(904) 321-5748
Email -
groland@nassaucountyfl.com hemmingway@nassaucountyfl.com
- Nassau County School Bus Transportation:
 - o Evelyn Mickey
Phone -(904) 225-0127
Fax -(904) 255-9404
Email -mckieev@nassau.k12.fl.us
- Nassau County Road & Bridge Department:
 - o Jennifer Kirkland
Phone -(904) 530-6175
Fax -(904) 530-6901
Email -jkirkland@nassaucountyfl.com
- Nassau County Manager's Office
 - o Sabrina Robertson
Phone- (904) 530-6010
Fax -(904) 321-5784
Email - SRobertson@nassaucountyfl.com
- United Postal Service (Yulee)
 - o Cassondra Mitchell
Phone -(904) 225-5331
Fax -(904) 225-9733
Email- cassondra.t.mitchell@usps.gov
- United Postal Service (Fernandina)
 - o EdwinLang
Phone -(904) 491-8102
Fax -(904) 277-7947
Email -edwin.p.lang@usps.gov
- United Postal Service (Callahan)
 - o Kim Vojtech
Phone- (904) 879-2131
Fax -(904) 879-6737
Email -kim.k.vojtech@usps.gov
- United Postal Service (Hilliard)
 - o Heather Ackerman
Phone -(904) 845-2151
Fax -(904) 845-7738
Email -heather.r.ackerman@usps.gov

Depending on the location of the project/detour, notification to other agencies may be required.

**Road Closure Policy
Page 3 of 3**



5. Signage will be in place prior to road closure. They will be bagged/covered until needed. VMBs, will be installed and operating a minimum of seven (7) calendar days prior to any closure/detour.

6. Visual inspection of the VMB by the Engineering Services Department is required at installation or relocation. Visual inspection of all road/detour signage shall be accomplished prior to road closure. Contact Engineering Services 48 hours prior to installation for inspection.

Project Description(s): _____

Financial Project Number(s): _____

In accordance with State law:

Section 287.133(2)(b), Florida Statutes, provides that public entities may not contract with firms that have been excluded from participating in the public contracting process.

A public entity may not accept any bid, proposal, or reply from, award any contract to, or transact any business in excess of the threshold amount provided in s. 287.017, F.S., for CATEGORY TWO with any person or affiliate on the convicted vendor list for a period of 36 months following the date that person or affiliate was placed on the convicted vendor list unless that person or affiliate has been removed from the list pursuant to Section 287.133(3)(f), F.S. A public entity that was transacting business with a person at the time of the commission of a public entity crime resulting in that person being placed on the convicted vendor list may not accept any bid, proposal, or reply from, award any contract to, or transact any business with any other person who is under the same, or substantially the same, control as the person whose name appears on the convicted vendor list so long as that person's name appears on the convicted vendor list.

A contract award (reference 2 CFR 1200 and 2 CFR 180) must not be made to parties listed on the government-wide Excluded Parties List System in the System for Award Management (SAM), in accordance with the OMB guidelines at 2 CFR 180 that implement Executive Orders 12549 (3 CFR Part 1986 Comp., p. 189) and 12689 (3 CFR Part 1989 Comp., p. 235), "Debarment and Suspension." Pursuant to 23 CFR 172.7(b)(3), a contracting agency shall verify suspension and debarment actions and eligibility status of consultants and subconsultants prior to entering into an agreement or contract in accordance with 2 CFR part 1200 and 2 CFR part 180, when the identities of such subconsultants are known prior to execution of the subject agreement or contract. The Excluded Parties List System in SAM contains the names of parties debarred, suspended, or otherwise excluded by agencies, as well as parties declared ineligible under statutory or regulatory authority other than Executive Order 12549.

The Convicted Vendor List/ Suspended Vendor List / Discriminatory Vendor List / Federal Excluded Parties List/ Vendor Complaint Lists are available at the following Department of Management Services site:

http://www.dms.myflorida.com/business_operations/state_purchasing/vendor_information/convicted_suspended_discriminatory_complaints_vendor_lists

Section 287.135, F.S. prohibits a company from bidding on, submitting a proposal for, or entering into or renewing a contract for goods or services of any amount if the company is on the Scrutinized Companies that Boycott Israel List, created pursuant to Section 215.4725, F.S. or is engaged in a boycott of Israel. Section 287.135, F.S. also prohibits a company from bidding on, submitting a proposal for, or entering into or renewing a contract for goods or services of \$1,000,000 or more, if the company is on either the Scrutinized Companies with Activities in Sudan List, or the Scrutinized Companies with Activities in the Iran Petroleum Energy Sector Lists which are created pursuant to s. 215.473, F.S.

NASSAU COUNTY INVITATION TO BID

NC21-014-ITB - CR-121, S. 14TH ST., CHESTER RD., SADLER RD., & AMELIA CONCOURSE

The List of Scrutinized Companies that Boycott Israel, and the Scrutinized List of Prohibited Companies (Activities in Sudan/Iran Petroleum Energy Sector) are available at the following Florida State Board of Administration site:

<https://www.sbafla.com/fsb/FundsWeManage/FRSPensionPlan/GlobalGovernanceMandates.aspx>

I have checked the aforementioned lists that apply to this procurement, as applicable to verify that the vendor (and all subs where known) is eligible for contract award/execution:

Procurement Office or Contracting Awarding Office:

Printed Name

Signature

Date: _____



Nassau County Engineering Services Department
96161 Nassau Place
Yulee, Florida 32097

Robert T. Companion, P.E.
County Engineer

AS-BUILTS REQUIREMENT CHECKLIST:

The Following list is intended to highlight the majority of the as-built requirements for Construction projects in Nassau County. This list should not be considered to be all-inclusive as each project is unique in nature and may require additional information that can only be determined during the course of the project's completion. Generally, however, the AS-BUILT information shall contain the following:

1. AS-BUILTS should be based on the design plans as approved through the DRC process. The submitted as-builts should be at the same scale and have the same orientation as the design files.
2. AS-BUILTS should have the same page numbering as the design plans, and the cover of the AS-BUILT plans should have all sheets from the design plans listed with sheets not "AS-BUILT" stricken through.
3. AS-BUILTS should display the original design information as displayed on the plan sheets with the design information stricken through and the as-built information displayed in bold adjacent to the design information.
4. AS-BUILTS shall be accompanied by an "Engineer's Certification" form from the Engineer of Record. (Exhibit 3&4)
5. Three (3) sets of fully signed and sealed AS-BUILTS should be submitted along with a CADD file(s) containing the AS-BUILT information. CADD files should be in State Plane coordinates (NAD 83) with a vertical datum of NGVD 1929. Furthermore, CADD files should be submitted in ACAD 2004 or ACAD 2006 only.
6. Northings and Easting of all drainage structures should be included.
7. The plans should be clearly legible and all structure notes, distances, angles and elevations should be clearly readable.
8. If the plan represents a phase of a development, then that phase should be clearly identified for clarity and avoid confusion with future phases.
9. There should be a north arrow and scale on each sheet.

AS-BUILTS REQUIREMENT CHECKLIST

Page | 2

10. A legend should be included explaining the symbols used in the plans.
11. ALL sheets must be signed and sealed by a surveyor licensed in the State of Florida.
12. There should be sufficient "plan" and "as-built" elevations shown to verify that the streets were constructed substantially in accordance with the approved construction plans. Generally, the County will review all low points and high points in the street and verify that the minimum grade exists for each street. On straight sections between high and low points elevations should be taken every 200 feet.
13. All street curve radii should be shown on the plans or in a table.
14. Street widths and curb type should be identified for each street on each sheet.
15. Whenever there are islands within the streets the as-builts should include dimensions for these islands.
16. The paved radii of all Cul-de-Sacs should be listed and Cul-De-Sac center and edge of pavement or gutter elevations at quarter points shall be shown.
17. All underdrains should be shown with size, lengths, inverts and cleanouts all shown.
18. Where swales are utilized there should be sufficient flow line elevations and ditch cross sections to verify capacity of the channel.
19. There should be a comparison table of design and as-built pipe sizes, lengths, invert elevations, and pipe slopes.
20. The as-built surface area of the pond(s) at Normal Water Level (design) and Top of Bank (as-built) should be included.
21. The bottom elevation and area should be shown (2 locations min. per pond).
22. The surveyor shall certify by note (for each pond) that no slope is greater than 1:4 above the design NWL, unless the pond is fenced.
23. All structures in the pond (overflow weirs, etc.) should be included.

AS-BUILTS REQUIREMENT CHECKLIST

Page | 3

24. All watermain and sewermain locations, dimensions, etc.

25. All easements required (or on a plat) should be shown on the "As-Builts" and improvement located so as to verify improvements are within the easement. Easement not recorded as part of the recorded plat including drainage and right-of-way easements shall also be identified as "as-built". For these easements the book and page of their record, property to whom easement is dedicated and date of filing should be shown on as the "as-built". All improvements intended to be within these easements shall be shown as the "as-builts" to verify the improvements are within the easement. Wetlands are not reviewed by Nassau County and need not be shown.

EXHIBIT 1

GENERAL INFORMATION AND INSURANCE REQUIREMENTS

GENERAL INFORMATION AND MINIMUM INSURANCE REQUIREMENTS

COMMERCIAL GENERAL LIABILITY INSURANCE

The Contractor shall purchase and maintain at the Contractor's expense Commercial General Liability insurance coverage (ISO or comparable Occurrence Form) for the life of this Contract. Modified Occurrence or Claims Made forms are not acceptable.

The Limits of this insurance shall not be less than the following limits:

Each Occurrence Limit	\$1,000,000
Personal & Advertising Injury Limit	\$1,000,000
Fire Damage Limit (any one fire)	\$ 300,000
Medical Expense Limit (any one person)	\$ 10,000
Products & Completed Operations Aggregate Limit	\$2,000,000
General Aggregate Limit (other than Products & Completed Operations) Applies Per Project	\$2,000,000

General liability coverage shall continue to apply to "bodily injury" and to "property damage" occurring after all work on the Site of the covered operations to be performed by or on behalf of the additional insureds has been completed and shall continue after that portion of "your work" out of which the injury or damage arises has been put to its intended use.

WORKERS' COMPENSATION AND EMPLOYER'S LIABILITY INSURANCE

The Contractor shall purchase and maintain at the Contractor's expense Workers' Compensation and Employer's Liability insurance coverage for the life of this Contract.

The Limits of this insurance shall not be less than the following limits:

<u>Part One</u> – Workers' Compensation Insurance – Unlimited	
Statutory Benefits as provided in the Florida Statutes and	
<u>Part Two</u> – Employer's Liability Insurance	
Bodily Injury By Accident	\$500,000 Each Accident
Bodily Injury By Disease	\$500,000 Policy Limit
Bodily Injury By Disease	\$500,000 Each Employee

*If leased employees are used, policy must include an Alternate Employer's Endorsement

AUTOMOBILE LIABILITY INSURANCE

The Contractor shall purchase and maintain at the Contractor's expense Automobile Liability insurance coverage for the life of this Contract.

The Limits of this insurance shall not be less than the following limits:

Combined Single Limit – Each Accident	\$1,000,000
---------------------------------------	-------------

Covered Automobiles shall include any auto owned or operated by the insured Contractor, insured Sub-subcontractor including autos which are leased, hired, rented or borrowed, including autos owned by their employees which are used in connection with the business of the respective Contractor or Sub-subcontractor.

UMBRELLA INSURANCE

The Contractor shall purchase and maintain at the Contractor's expense Umbrella Liability (Umbrella Form) insurance coverage for the life of this Contract.

The Limits of this insurance shall not be less than the following limits:

Each Occurrence Limit	\$1,000,000
Aggregate Limit	\$1,000,000

Contractor shall require each of his Subcontractors to likewise purchase and maintain at their expense Commercial General Liability insurance, Workers' Compensation and Employer's Liability coverage, Automobile Liability insurance, Umbrella Liability insurance coverage meeting the same limit and requirements as the Contractors insurance.

Certificates of Insurance acceptable to Nassau County Board of County Commissioners for the Contractor/Vendor's insurance must be received within ten (10) days of Notification of Selection and at time of signing Agreement.

Certificates of Insurance and the insurance policies required for this Agreement shall contain an endorsement that coverage afforded under the policies will not be cancelled or allowed to expire until at least thirty (30) days prior written notice has been given to Nassau County Board of County Commissioners.

Certificates of Insurance and the insurance policies required for this Agreement will include a provision that policies, except Workers' Compensation, are primary and noncontributory to any insurance maintained by the Contractor.

Nassau County Board of County Commissioners must be named as an Additional Insured and endorsed onto the Commercial General Liability (CGL), Auto Liability and Umbrella Liability policy (ies). A copy of the endorsement(s) must be supplied to Nassau County Board of County Commissioners ten (10) days following the execution of the agreement or prior to the first date of services, whichever comes first.

CGL policy Additional Insured Endorsement must include Ongoing and Completed Operations (Form CG2010 11 84 **OR** Form CG2010 04 13 and GC2037 04 13 edition or equivalent). Other Additional Insured forms might be acceptable but only if modified to delete the word "ongoing" and insert the sentence "Operations include ongoing and completed operations".

CGL policy shall not be endorsed with Exclusion - Damage to Work performed by Subcontractors on Your Behalf (CG2294 or CG2295)

CGL policy shall not be endorsed with Contractual Liability Limitation Endorsement (CG2139) or Amendment of Insured Contract Definition (CG 2426)

CGL policy shall not be endorsed with Exclusion - Damage to Premises Rented to you (CG 2145)

CGL policy shall include broad form contractual liability coverage for the Contractors covenants to and indemnification of the Authority under this Contract

Certificates of Insurance and the insurance policies required for this Agreement shall contain a provision under General Liability, Auto Liability and Workers' Compensation to include a Waiver of Subrogation clause in favor of Nassau County Board of County Commissioners.

All Certificates of Insurance shall be dated and shall show the name of the insured Contractor, the specific job by name and job number, the name of the insurer, the policy number assigned its effective date and its termination date and a list of any exclusionary endorsements.

All Insurers must be authorized to transact insurance business in the State of Florida as provided by Florida Statute 624.09(1) and the most recent Rating Classification/Financial Category of the insurer as published in the latest edition of "Best's Key Rating Guide" (Property-Casualty) must be at least A- or above.

All of the above referenced Insurance coverage is required to remain in force for the duration of this Agreement and for the duration of the warranty period. Accordingly, at the time of submission of final application for payment, Contractor shall submit an additional Certificate of Insurance evidencing continuation of such coverage.

If the Contractor fails to procure, maintain or pay for the required insurance, Nassau County Board of County Commissioners shall have the right (but not the obligation) to secure same in the name of and for the account of Contractor, in which event, Contractor shall pay the cost thereof and shall furnish upon demand, all information that may be required to procure such insurance. Nassau County Board of County Commissioners shall have the right to back-charge contractor for the cost of procuring such insurance. The failure of Nassau County Board of County Commissioners to demand certificates of insurance and endorsements evidencing the required insurance or to identify any deficiency in contractors coverage based on the evidence of insurance provided by the contractor shall not be construed as a waiver by Nassau County Board of County Commissioners of contractor's obligation to procure, maintain and pay for required insurance.

The insurance requirements set forth herein shall in no way limit Contractors liability arising out of the work performed under the Agreement or related activities. The inclusions, coverage and limits set forth herein are minimum inclusion, coverage and limits. The required minimum policy limits set forth shall not be construed as a limitation of Contractor's right under any policy with higher limits, and no policy maintained by the Contractor shall be construed as limiting the type, quality or quantity of insurance coverage that Contractor should maintain. Contractor shall be responsible for determining appropriate inclusions, coverage and limits, which may be in excess of the minimum requirements set forth herein.

If the insurance of any Contractor or any subcontractor contains deductible(s), penalty(ies) or self-insured retention(s), the Contractor or Subcontractor whose insurance contains such provision(s) shall be solely responsible for payment of such deductible(s), penalty(ies) or self-insured retention(s).

The failure of Contractor to fully and strictly comply at all times with the insurance requirements set forth herein shall be deemed a material breach of the Agreement.

RAILROAD PROTECTIVE LIABILITY INSURANCE

The Contractor shall purchase and maintain at the Contractor's expense Railroad Protective Liability insurance coverage for the life of this Contract.

Railroad Protective Liability Insurance in the amounts of \$2,000,000 per occurrence and \$6,000,000 aggregate and it is required to name the specific railroad as the named insured.

In addition to providing Railroad Protective Liability insurance and Contractor is required to provide current proof of Commercial General Liability insurance naming the specific Railroad as additional insured. This coverage must meet minimum requirements of \$2M per occurrence and \$6M aggregate.

The General Liability certificate is also required to show proof of CG2417 or its equivalent as well as a waiver of subrogation in favor of the Railroad.

If you have questions or require additional information on how to obtain Railroad Protective Insurance coverage, please contact First Coast Railroad at (800) 757-7387, Ext. 3273 or fcrd-cs@gwrr.com.

**EXHIBIT 2 -
CONTRACTOR'S BID**

NASSAU COUNTY INVITATION TO BID
NC21-014-ITB - CR-121, S. 14TH ST., CHESTER RD., SADLER RD., & AMELIA CONCOURSE

SECTION 00 41 15

BID FORM

PROJECT IDENTIFICATION: CR-121, S. 14TH ST., CHESTER RD., SADLER RD., & AMELIA CONCOURSE
Bid Number NC21-014-ITB
Nassau County, Florida

BID DEADLINE: November 9, 2021 at 10:00 AM ET
THIS BID IS SUBMITTED TO: Board of County Commissioners, Nassau County
Office of the Ex-Officio Clerk
76347 Veterans Way
Suite 456
Yulee, Florida 32097

1.01 The undersigned Bidder proposes and agrees, if this Bid is accepted, to enter into an agreement with the County in the form included in the Bidding Documents to perform all Work as specified or indicated in the Bidding Documents for the prices and within the times indicated in this Bid and in accordance with the other terms and conditions of the Bidding Documents.

Company Name (typed or printed): ACME BARRICADES LC
Business address: 9800 NORLANDY BLVD JACKSONVILLE FL 32221
Phone No.: 904-781-1950 Fax No.: _____
Contact Name: JOHAI SIMMS
Contact Title: REGIONAL MANAGER
Contact email address: J.SIMMS@ACMEBARRICADES.COM

2.01 Bidder accepts all of the terms and conditions of the Advertisement or Invitation to Bid and Instructions to Bidders, including without limitation those dealing with the disposition of Bid security. The Bid will remain subject to acceptance for 90 days after the Bid opening, or for such longer period of time that Bidder may agree to in writing upon request of the County.

3.01 In submitting this Bid, Bidder represents, as set forth in the Agreement, that:

A. Bidder has examined and carefully studied the Bidding Documents, the other related data identified in the Bidding Documents, and the following Addenda, receipt of all which is hereby acknowledged:

Addendum No.	Addendum Date
<u>A 1</u>	<u>11/14/2021</u>
<u>A 2</u>	<u>12/12/2021</u>
<u>A 3</u>	<u>12/13/2021</u>

B. Bidder has visited the Site and become familiar with and is satisfied as to the general, local and Site conditions that may affect cost, progress, and performance of the Work.

NASSAU COUNTY INVITATION TO BID
NC21-014-ITB - CR-121, S. 14TH ST., CHESTER RD., SADLER RD., & AMELIA CONCOURSE

- C. Bidder is familiar with and is satisfied as to all federal, state and local Laws and Regulations that may affect cost, progress and performance of the Work.
 - D. Bidder has carefully studied all: (1) reports of explorations and tests of subsurface conditions at or contiguous to the Site and all drawings of physical conditions in or relating to existing surface or subsurface structures at or contiguous to the Site (except Underground Facilities) which have been identified in the plans and technical specifications as provided in paragraph 4.02 of the General Conditions, and (2) reports and drawings of a Hazardous Environmental Condition, if any, which has been identified in the plans and technical specifications as provided in paragraph 4.06 of the General Conditions.
 - E. Bidder has obtained and carefully studied (or assumes responsibility for having done so) all additional or supplementary examinations, investigations, explorations, tests, studies, and data concerning conditions (surface, subsurface and Underground Facilities) at or contiguous to the Site which may affect costs, progress, or performance of the Work or which relate to any aspect of the means, methods, techniques, sequences, and procedures of construction to be employed by Bidder, including applying the specific means, methods, techniques, sequences, and procedures of construction expressly required by the Bidding Documents to be employed by Bidder, and safety precautions and programs incident thereto.
 - F. Bidder does not consider that any further examinations, investigations, explorations, tests, studies, or data are necessary for the determination of this Bid for performance of the Work at the price(s) bid and within the times and in accordance with the other terms and conditions of the Bidding Documents.
 - G. Bidder is aware of the general nature of the work to be performed by the County and others at the Site that relates to the Work as indicated in the Bidding Documents.
 - H. Bidder has correlated the information known to Bidder, information and observations obtained from visits to the Site, reports and drawings identified in the Bidding Documents, and all additional examinations, investigations, explorations, tests, studies, and data with the Bidding Documents.
 - I. Bidder has given Engineer of Record written notice of all conflicts, errors, ambiguities, or discrepancies that Bidder has discovered in the Bidding Documents, and the written resolution thereof by Engineer of Record is acceptable to Bidder.
 - J. The Bidding Documents are generally sufficient to indicate and convey understanding of all terms and conditions for the performance of the Work for which this Bid is submitted.
- 4.01** Bidder further represents that this Bid is genuine and not made in the interest of or on behalf of any undisclosed individual or entity and is not submitted in conformity with any agreement or rules of any group, association, organization or corporation; Bidder has not directly or indirectly induced or solicited any other Bidder to submit a false or sham Bid; Bidder has not solicited or induced any individual or entity to refrain from bidding; and Bidder has not sought by collusion to obtain for itself any advantage over any other Bidder or over the County.

NASSAU COUNTY INVITATION TO BID
NC21-014-ITB - CR-121, S. 14TH ST., CHESTER RD., SADLER RD., & AMELIA CONCOURSE

- 5.01** Neither the Recipient nor any of its contractors or their subcontractors shall enter into any contract, subcontract or arrangement in connection with the Project or any property included or planned to be included in the Project in which any member, officer or employee of the Recipient or the locality during tenure or for 2 years thereafter has any interest, direct or indirect. If any such present or former member, officer or employee involuntarily acquires or had acquired prior to the beginning of tenure any such interest, and if such interest is immediately disclosed to the Recipient, the Recipient, with prior approval of the Department, may waive the prohibition contained in this paragraph provided that any such present member, officer or employee shall not participate in any action by the Recipient or the locality relating to such contract, subcontract or arrangement. The Recipient shall insert in all contracts entered into in connection with the Project or any property included or planned to be included in any Project, and shall require its contractors to insert in each of their subcontracts, the following provision:

"No member, officer or employee of the Recipient or of the locality during his tenure or for 2 years thereafter shall have any interest, direct or indirect, in this contract or the proceeds thereof."

The provisions of this paragraph shall not be applicable to any agreement between the Recipient and its fiscal depositories or to any agreement for utility services the rates for which are fixed or controlled by a governmental agency.

- 6.01** Bidder will complete the Work in accordance with the Contract Documents for the following price(s):

[Price sheet begins on the next page.]

NASSAU COUNTY INVITATION TO BID
NC21-014-ITB - CR-121, S. 14TH ST., CHESTER RD., SADLER RD., & AMELIA CONCOURSE

BID TAB
CR-121, S. 14TH ST., CHESTER RD., SADLER RD., & AMELIA CONCOURSE

PAY ITEM NO.	PAY ITEM DESCRIPTION	UOM	QTY	UNIT PRICE	TOTAL COST
0101-1	MOBILIZATION	LS	1	\$25,000.00	\$25,000.00
102-1	MAINTENANCE OF TRAFFIC	LS	1	\$25,000.00	\$25,000.00
700-1-11	SINGLE POST SIGN (F&I) (GROUND MOUNT) (UP TO 12 SF)	AS	71	\$475.00	\$33,725.00
700-1-12	SINGLE POST SIGN (F&I) (GROUND MOUNT) (12-20 SF)	AS	49	\$1950.00	\$95,550.00
700-1-13	SINGLE POST SIGN (F&I) (GROUND MOUNT) (21-30 SF)	AS	1	\$2000.00	\$2000.00
700-1-60	SINGLE POST SIGN (REMOVE)	AS	77	\$50.00	\$3850.00
700-3-501	SIGN PANEL, RELOCATE, UP TO 12 SF	EA	56	\$100.00	\$5600.00
700-3-601	SIGN PANEL, REMOVE, UP TO 12 SF	EA	1	\$50.00	\$50.00
700-13-15	RETROREFLECTIVE SIGN STRIP (F&I) (5')	EA	166	\$100.00	\$16,600.00
701-18-101	PROFIED THERMOPLASTIC (STANDARD) (ASPHALT SURFACES) (WHITE) (SOLID) (6")	GM	16.688	\$9500.00	\$158,536.00
705-10-1	OBJECT MARKER (TYPE 1)	EA	51	\$200.00	\$10,200.00
706-1-1	RAISED PAVEMENT MARKER, TYPE B WITHOUT FINAL SURFACE MARKINGS	EA	188	\$10.00	\$1,880.00
710-90	PAINTED PAVEMENT MARKINGS – FINAL SURFACE	LS	1	\$25,698.30	\$25,698.30
*	RETRO-REFLECTIVE PAVEMENT MARKER	EA	264	\$10.00	\$2640.00
*	PAINTED PAVEMENT MARKINGS, STANDARD, WHITE, SOLID, 6"	GM	14.958	\$1350.00	\$20,193.30
*	PAINTED PAVEMENT MARKINGS, STANDARD, WHITE, SOLID FOR STOP LINE, 24"	LF	56	\$6.00	\$336.00
*	PAINTED PAVEMENT MARKINGS, STANDARD, WHITE, MESSAGE OR SYMBOL	EA	3	\$100.00	\$300.00
*	PAINTED PAVEMENT MARKINGS, STANDARD, YELLOW, SOLID 6"	GM	1.082	\$1500.00	\$1,623.00
*	PAINTED PAVEMENT MARKINGS, STANDARD, YELLOW, SKIP, 6"	GM	.606	\$1000.00	\$606.00
711-11-123	THERMOPLASTIC (STANDARD) (WHITE) (SOLID) (12")	LF	4059	\$5.00	\$20,295.00
711-11-125	THERMOPLASTIC (STANDARD) (WHITE) (SOLID) (24")	LF	65	\$10.00	\$650.00
711-11-160	THERMOPLASTIC (STANDARD) (WHITE) (MESSAGE OR SYMBOL)	EA	2	\$300.00	\$600.00
711-14-125	THERMOPLASTIC (PERFORMED) (WHITE) (SOLID) (24")(CROSSWALK)	LF	2930	\$25.00	\$73,250.00
711-16-201	THERMOPLASTIC (STANDARD-OTHER SURFACES) (YELLOW) (SOLID) (6")	GM	1.122	\$6000.00	\$6,732.00

NASSAU COUNTY INVITATION TO BID
NC21-014-ITB - CR-121, S. 14TH ST., CHESTER RD., SADLER RD., & AMELIA CONCOURSE

711-16-231	THERMOPLASTIC (STANDARD-OTHER SURFACES) (YELLOW) (10/30 SKIP) (6")	GM	0.436	\$ 3,000.00	\$ 1,308.00
711-17-1	THERMOPLASTIC, REMOVE - SURFACE TO REMAIN	SF	50318	\$ 2.50	\$ 125,795.00

*THESE QUANTITIES ARE PAID FOR UNDER PAINTED PAVEMENT MARKINGS (FINAL SURFACE), LUMP SUM ITEM 710-90. THE QUANTITIES ARE FOR ONE APPLICATION; SEE SPECIFICATION 710 FOR THE NUMBER OF APPLICATIONS REQUIRED.

BASE BID TOTAL

\$ 658,017.60
(Use Figures)

SIX HUNDRED FIFTY EIGHT THOUSAND SEVENTEEN DOLLARS AND SIXTY CENTS
(Use Words)

NASSAU COUNTY INVITATION TO BID
NC21-014-ITB - CR-121, S. 14TH ST., CHESTER RD., SADLER RD., & AMELIA CONCOURSE

All specific cash allowances are included in the price(s) set forth above and have been computed in accordance with paragraph 11.02 of the General Conditions.

Unit prices have been computed in accordance with Paragraph 11.03.B of the General Conditions.

Bidder acknowledges that estimated quantities are not guaranteed and are solely for the purpose of comparison of Bids. Final payment of all Unit Price Bid Items will be based on actual quantities as determined in the Contract Documents.

- 6.01** Bidder agrees that the Work will be substantially complete within 45 calendar days after the date when the Contract Times commence to run as provided in paragraph 2.03 of the General Conditions, and completed and ready for final payment in accordance with paragraph 14.07.B of the General Conditions within 15 calendar days from the date of substantial completion. Total contract time shall be 60 calendar days; for everyday the work goes beyond substantial completion; a day will be removed from final completion so the total days equal 60 calendar days.
- 6.02** Bidder accepts the provisions of the Agreement as to liquidated damages in the event of failure to complete the Work within the times specified above, which shall be stated in the Agreement.
- 7.01** The following documents are attached to and made a condition of this Bid:
- A. Bid Security in the form of a certified check of Bid Bond (Section 00 43 15)
 - B. Tabulation of Subcontractors & Suppliers (Section 00 43 35)
 - C. Florida Trench Safety Act Certification (Section 00 44 55)
 - D. Drug-Free Workplace Certificate (Section 00 45 20)
 - E. Public Entity Crimes Statement (Section 00 45 30)
 - F. Statement of Disputes, Litigation & Surety Completion (Section 00 45 35)
 - G. LAP Certification of Current Capacity
 - H. Bid Opportunity List for Commodities & Contractual Services
 - I. Non-Collusion Declaration and Compliance Form
 - J. Certification Regarding Debarment, Suspension, Ineligibility and Voluntary Exclusion
 - K. Certification for Disclosure of Lobbying Activities
- 8.01** The terms used in this Bid with initial capital letters have the meanings indicated in the Instructions to Bidders, the General Conditions, and the Supplementary Conditions.

NASSAU COUNTY INVITATION TO BID
NC21-014-ITB - CR-121, S. 14TH ST., CHESTER RD., SADLER RD., & AMELIA CONCOURSE

SUBMITTED on December 20th . 2021

State License No. _____

If Bidder is:

An Individual

Name (typed or printed): _____

By: _____

(Individual's Signature)

Doing business as: _____

Business address: _____

Phone No.: _____ Fax No.: _____

A Partnership

Partnership Name: _____

By: _____

(Signature of general partner - attach evidence of authority to sign)

Name (typed or printed): _____

Business address: _____

Phone No.: _____ Fax No.: _____

A Corporation

Corporation Name: ACME BARRICADES, L.C. (SEAL)

State of Incorporation: Florida

Type (General Business, Professional, Service, Limited Liability): General Business

By: _____

(Signature - attach evidence of authority to sign)

Name (typed or printed): Christian Cummings

Title: CEO (CORPORATE SEAL)

Attest KWJ

(Signature of Corporate Secretary)

Business address: 9800 Normandy Blvd

Jacksonville Florida 32221

Phone No.: 904-781-1950 Fax No.: 904-781-1921

Date of Qualification to do business is _____

NASSAU COUNTY INVITATION TO BID
NC21-014-ITB - CR-121, S. 14TH ST, CHESTER RD., SADLER RD., & AMELIA CONCOURSE

A Joint Venture

Joint Venturer Name: _____
By: _____
(Signature of joint venture partner - attach evidence of authority to sign)
Name (typed or printed): _____
Title: _____
Business address: _____

Phone No.: _____ Fax No.: _____

Joint Venturer Name: _____
By: _____
(Signature - attach evidence of authority to sign)
Name (typed or printed): _____
Title: _____
Business address: _____

Phone No.: _____ Fax No.: _____

Phone and FAX Number, and Address for receipt of official communications:

(Each joint venturer must sign. The manner of signing for each individual, partnership, and corporation that is a party to the joint venture should be in a manner indicated above.)

[Remainder of the page intentionally blank.]

NASSAU COUNTY INVITATION TO BID
 NC21-014-ITB - CR-121, S. 14TH ST., CHESTER RD., SADLER RD., & AMELIA CONCOURSE

SECTION 00 43 35

TABULATION OF SUBCONTRACTORS & SUPPLIERS

The undersigned states that the following is a full and complete list of the proposed subcontractors and suppliers on this Project. Provide the class of work and percentage of work to be performed by each. This list will not be added to nor altered without written consent to the Owner through the Engineer.

<u>SUBCONTRACTOR OR SUPPLIER AND ADDRESS</u>	<u>CLASS OF WORK OR MATERIAL/PERCENTAGE</u>
1. <u>CROWN TECHNOLOGES</u> <u>39 Industrial Park Dr Waukegan IL 3029</u>	<u>THERMOPLASTIC STANDARD PREFORMED</u>
2. <u>EVANS FLOTT TAIL</u> <u>4161 PREDATOR PKWY DUNN ST. CROMWELL NC 27910</u>	<u>THERMOPLASTIC STANDARD PREFORMED</u>
3. <u>3M</u> <u>3M CENTER ST PAUL MN 55144</u>	<u>RPM'S</u>
4. <u>PRIOR ENTERPRISES INC</u> <u>2024 US 90 SANDERSVILLE GA 32087</u>	<u>STANDARD PART</u>
5. <u>POTTER'S INDUSTRIES</u> <u>P.O. Box 641 Valley Forge PA 17862</u>	<u>G-LISS SPHERICAL</u>
6. _____	_____
7. _____	_____

BIDDER: ALICE DOMICANES LC
 By: [Signature]
 Name: Christina Cummings
 Title: CEO
 Date: 12/1/2021

NASSAU COUNTY INVITATION TO BID
NC21-014-ITB - CR-121, S. 14TH ST., CHESTER RD., SADLER RD., & AMELIA CONCOURSE

SECTION 00 44 55

FLORIDA TRENCH SAFETY ACT CERTIFICATION

Bidder acknowledges that included in the various items of the proposal and in the Total Bid Price are costs for complying with the Florida Trench Safety Act (90-96, Laws of Florida) as modified October 1, 2008. The Bidder further identifies the costs to be summarized below:

	<u>Cost</u>
1. Trench Safety Act Compliance	\$ <u>0</u>
2. Special Shoring	\$ <u>0</u>

Identify method of compliance for Item #1: N/A

Identify or attach a copy of Special Shoring requirements for Item #2: N/A

The undersigned certifies that he/she is the Contractor who will perform the trench excavation for this project, and hereby gives written assurance that Contractor will comply with the applicable trench safety standards specifically set forth in Florida's Trench Safety Act, Laws of Florida, 90-96.

BIDDER: ALMA OBRICADOS LC
By: [Signature]
Name: CHRISTIAN [Signature]
Title: CFO

STATE of FLORIDA

COUNTY of DUVAL

Sworn to and subscribed before me by means of physical presence or online notarization on this 20th day of December, 2021.

[Signature]
Notary Public

My Commission Expires: 8/31/2023

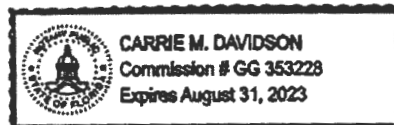

NASSAU COUNTY INVITATION TO BID
NC21-014-ITB - CR-121, S. 14TH ST., CHESTER RD., SADLER RD., & AMELIA CONCOURSE

SECTION 00 45 20

DRUG FREE WORKPLACE CERTIFICATE

I, the undersigned, in accordance with Florida Statute 287.087, hereby certify that ACME (INCORPORATED) LLC (print or type name of firm)

- Publishes a written statement notifying that the unlawful manufacture, distribution, dispensing, possession or use of a controlled substance in the workplace named above that specifies actions that will be taken against violations of such prohibition.
- Informs employees about the dangers of drug abuse in the workplace, the firm's policy of maintaining a drug free working environment, and available drug counseling, rehabilitation, and employee assistance programs, and the penalties that may be imposed upon employees for drug use violations.
- Gives each employee engaged in providing commodities or contractual services that are under bid or proposal, a copy of the statement specified above.
- Notifies the employees that as a condition of working on the commodities or contractual services that are under bid or proposal, the employee will abide by the terms of the statement and will notify the employer of any conviction of, plea of guilty or nolo contendere to, any violation of Chapter 1893, or any controlled substance law of the State of Florida or the United States, for a violation occurring in the work place, no later than five (5) days after such conviction, and requires employees to sign copies of such written statement to acknowledge their receipt.
- Imposes a sanction on, or requires the satisfactory participation in, a drug abuse assistance or rehabilitation program, if such is available in the employee's community, by any employee who is so convicted.
- Makes a good faith effort to continue to maintain a drug free workplace through the implementation of a drug free workplace program.

NASSAU COUNTY INVITATION TO BID
NC21-014-ITB - CR-121, S. 14TH ST., CHESTER RD., SADLER RD., & AMELIA CONCOURSE

As a person authorized to sign a statement, I certify that the above-named business, firm, or corporation complies fully with the requirements set forth herein.

[Signature]
Authorized Signature
12/24/2021
Date Signed

State of: Florida

County of: Duval

Sworn to and subscribed before me by means of physical presence or online notarization on this 20th day of December, 2021 by Christian Cummings, CEO who is personally known to me or produced _____ as identification.
(Specify type of Identification)

[Signature]
Notary Public

8/31/23
My commission expires

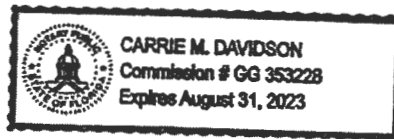

NASSAU COUNTY INVITATION TO BID
NC21-014-ITB - CR-121, S. 14TH ST., CHESTER RD., SADLER RD., & AMELIA CONCOURSE

SECTION 00 45 30

SWORN STATEMENT UNDER SECTION 287.133(3)(a),
FLORIDA STATUTES, ON PUBLIC ENTITY CRIMES

(To be signed in the presence of a notary public or other
officer authorized to administer oaths.)

STATE OF Florida

COUNTY OF Duval

Before me, the undersigned authority, personally appeared Cherisse Conroy, who being
by me first duly sworn, made the following statement:

1. The business address of ACME BRICKWORKS LC
(firm name of Bidder/Contractor)
is 9800 NORTHWAY BLVD JACKSONVILLE, FL 32221

2. My relationship to ACME BRICKWORKS LC
(firm name of Bidder/Contractor)
is CEO
(relationship such as sole proprietor, partner, president, vice president)

3. I understand that a public entity crime as defined in Section 287.133 of the Florida
Statutes includes a violation of any state or federal law by a person with respect to and directly related to
the transaction of business with any public entity in Florida or with an agency or political subdivision of
any other state or with the United States, including, but not limited to, any bid or contract for goods or
services to be provided to any public entity or such an agency or political subdivision and involving
antitrust, fraud, theft, bribery, collusion, racketeering, conspiracy, or material misrepresentation.

4. I understand that "convicted" or "conviction" is defined by the statute to mean a finding
of guilt or a conviction of a public entity crime, with or without adjudication or guilt, in any federal or state
trial of record relating to charges brought by indictment or information after July 1, 1989, as a result of a
jury verdict, nonjury trial, or entry of a plea of guilty or nolo contendere.

5. I understand that "affiliate" is defined by the statute to mean (1) a predecessor or
successor of a person or a corporation convicted of a public entity crime; or (2) an entity under control of
any natural person with is active in management of the entity and who has been convicted of a public
entity crime; (3) those officers, directors, executives, partners, shareholders, employees, members, and
agents who are active in the management of an affiliate; or (4) a person or corporation who knowingly
entered into a joint venture with a person who has been convicted of a public entity crime in Florida during
the preceding 36 months.

NASSAU COUNTY INVITATION TO BID
NC21-014-ITB - CR-121, S. 14TH ST., CHESTER RD., SADLER RD., & AMELIA CONCOURSE

6. Neither the Bidder/Contractor nor any officer, director, executive, partner, shareholder, employee, member or agent who is active in the management of the Bidder/Contractor, nor any affiliate of the Bidder/Contractor, has been convicted of a public entity crime subsequent to July 1, 1989.

(Draw a line through Paragraph 6 if Paragraph 7 below applies.)

7. There has been a conviction of a public entity crime by Bidder/Contractor, or an officer, director, executive, partner, shareholder, employee, member or agent of the Bidder/Contractor who is active in the management of the Bidder/Contractor or an affiliate of the Bidder/Contractor. A determination has been made pursuant to 287.133(3) by order of the Division of Administrative Hearings that it is not in the public interest of the name of the convicted person or affiliate to appear on the convicted vendor list.

The name of the convicted person or affiliate is Christian Cummings.

(Draw a line through Paragraph 7 if Paragraph 6 above applies.)

A copy of the order of the Division of Administrative Hearings is attached to this statement.

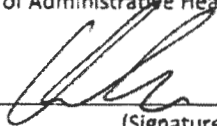

(Signature)

Sworn to and subscribed before me by means of physical presence or online notarization on this 20th day of December, 2021.

Carrie David

Notary Public

(affix seal)

My commission expires _____

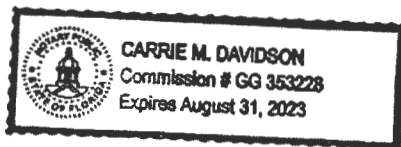

NASSAU COUNTY INVITATION TO BID
NC21-014-ITB - CR-121, S. 14TH ST., CHESTER RD., SADLER RD., & AMELIA CONCOURSE

SECTION 00 45 35

BIDDER'S STATEMENT OF DISPUTES, LITIGATION, ARBITRATION,
AND SURETY COMPLETION, LAST THREE (3) YEARS

<u>Project</u>	<u>Name and Address of Owner or Engineer</u>	<u>Name and Phone of Owner or Engineer Representative</u>	<u>Date of Contract</u>	<u>Amount</u>	<u>Status</u>
----------------	--	---	-----------------------------	---------------	---------------

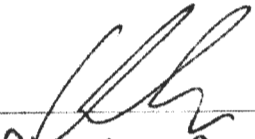
(Signed) 
Print Name Christian Cummings

Sworn to and subscribed before me by means of
 physical presence or online notarization on this
20th day of December, 2021.

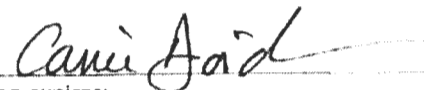
Notary Public 

My commission expires:

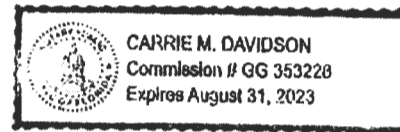

NASSAU COUNTY INVITATION TO BID
NC21-014-ITB - CR-121, S. 14TH ST., CHESTER RD., SADLER RD., & AMELIA CONCOURSE

Section 00 45 40
LAP FORMS

- LAP Certification of Current Capacity
- Bid Opportunity List for Commodities & Contractual Services
- Non-Collusion Declaration and Compliance Form
- Certification Regarding Debarment, Suspension, Ineligibility and Voluntary Exclusion
- Certification for Disclosure of Lobbying Activities
- DBE Bid Package Information

[Remainder of page intentionally left blank.]

NASSAU COUNTY INVITATION TO BID
NC21-014-ITB - CR-121, S. 14TH ST., CHESTER RD., SADLER RD., & AMELIA CONCOURSE

For bids to be received on 12/21/2021
(Letting Date)

Fill in your FDOT Vendor Number
VF54-3541899
(Only applicable to FDOT pre-qualified contractors)

CERTIFICATE

I hereby certify that the amount of any proposal submitted by this bidder for the above letting does not exceed the amount of the Firm's CURRENT CAPACITY (maximum capacity rating less total uncompleted work).

The total uncompleted work as shown on the "Status of Contracts on Hand" report (page 2) \$ _____

I further certify that the "Status of Contracts on Hand" report (page 2) was prepared as follows:

1. If the letting is before the 25th day of the month, the certificate and report reflect the uncompleted work as of the 15th day of the month, last preceding the month of the letting.
2. If the letting is after the 25th day of the month, the certificate and report reflects the uncompleted work in progress as of the 15th day of the month of the letting.
3. All new contracts (and subcontracts) awarded earlier than five days before the letting date are included in the report and charged against our total rating.

I certify that the information above is correct.

Sworn to and subscribed this 20th day
of December, 2020

ACME BARRICADES, L.C.
NAME OF FIRM
By: [Signature]
CEO
Title

PROJECTS	Classes of Work	Contract Amount	Amount Subject to	Balance of Contract	Balance of Contract
			Others	Amount	Amount to be completed by
E7J46	Roadway Signing	448,700	-	301,300	301,300
T7388	Pavement Marking	482,189	-	365,272	365,272
T7383	Pavement Marking	356,637	-	44,185	44,185
T7383	Pavement Marking	-	-	(34,908)	(34,908)
T7383	Roadway Signing	96,096	-	(21,420)	(21,420)
T7383	Roadway Signing	-	-	3,351	3,351
E8S59-R0	Pavement Marking	510,900	-	33,996	33,996
E8S59-R0	Pavement Marking	-	-	98,000	98,000
E1T58	Roadway Signing	687,605	-	616,880	616,880
E1T58	Pavement Marking	108,580	-	86,700	86,700
E1T82	Roadway Signing	37,335	-	3,135	3,135
E1T82	Pavement Marking	213,520	-	(54,890)	(54,890)
E1T83	Roadway Signing	12,855	-	1,315	1,315
E1T83	Pavement Marking	92,611	-	6,500	6,500
E3T93	Pavement Marking	436,931	-	288,778	288,778
E3T93	Roadway Signing	74,848	-	51,438	51,438
Z8098	Roadway Signing	294,850	-	294,850	294,850
E3U02	Pavement Marking	350,000	-	224,264	224,264
Z2211	Roadway Signing	704,060	-	704,060	704,060
Z3034	Roadway Signing	500,000	-	469,700	469,700
E3S19-R2	Roadway Signing	60,000	-	35,575	35,575
E7N70-R0	Pavement Marking	39,473	-	29,007	29,007
E7N70-R0	Roadway Signing	210,925	-	210,925	210,925
Z5065	Roadway Signing	11,139,100	-	11,139,100	11,139,100
E5V38	Roadway Signing	1,049,175	-	1,012,175	1,012,175
T2692	Pavement Marking	1,278,470	-	88,578	88,578
T2692	Pavement Marking	-	-	59,355	59,355
T7396	Roadway Signing	377,330	-	369,380	369,380
T5628	Roadway Signing	80,231	-	68,081	68,081
T5628	Pavement Marking	765,821	-	403,971	403,971
E8R65	Roadway Signing	1,286,135	-	499,515	499,515
T3730	Roadway Signing	60,000	-	60,000	60,000
T2744	Roadway Signing	189,500	-	189,500	189,500

T5668	Pavement Marking	7,600	-	78,222	78,222
E3Q29	Roadway Signing	492,780	-	219,925	219,925
T4434	Roadway Signing	-	-	145,352	145,352
T2739	Roadway Signing	1,050	-	1,050	1,050
E1Q77	Roadway Signing	27,540	-	1,454	1,454
E8R45	Roadway Signing	215,578	-	213,478	213,478
T4472	Roadway Signing	305,180	-	276,920	276,920
E8R84	Roadway Signing	1,400	-	1,400	1,400
T7433	Roadway Signing	193,785	-	193,785	193,785
T3714	Roadway Signing	117,140	-	117,140	117,140
T3529	Roadway Signing	38,970	-	30,516	30,516
T3529	Roadway Signing	-	-	17,020	17,020
T2732	Roadway Signing	144,985	-	144,985	144,985
T1724	Roadway Signing	44,975	-	44,975	44,975
T5552	Roadway Signing	180,324	-	(7,171)	(7,171)
E8R57	Pavement Marking	33,113	-	9,503	9,503
E3N51	Roadway Signing	210,617	-	52,557	52,557
E3N51	Roadway Signing	-	-	230,220	230,220
T2724	Roadway Signing	647,115	-	647,115	647,115
E5271	Roadway Signing	46,165	-	46,165	46,165
T3660	Roadway Signing	11,960	-	11,960	11,960
T3689	Roadway Signing	1,200	-	1,200	1,200
T3579	Roadway Signing	136,925	-	76,028	76,028
T3579	Roadway Signing	-	-	750	750
E5W13 Area 1	Roadway Signing	150,000	-	86,646	86,646
E5W13 Area 2	Roadway Signing	1,040,508	-	927,879	927,879
E5W13 Area 3	Roadway Signing	104,815	-	10,456	10,456
E5W13 Area 4	Roadway Signing	847,944	-	453,067	453,067
E5W13 Area 5	Roadway Signing	532,606	-	92,366	92,366
T2756	Roadway Signing	154,245	-	78,235	78,235
E7R12	Roadway Signing	-	-	5,359	5,359
E7R12	Pavement Marking	-	-	93,028	93,028
T3745	Roadway Signing	14,580	-	14,580	14,580
T3745	Roadway Signing	-	-	17,815	17,815
T3725	Roadway Signing	13,190	-	13,190	13,190

T4477	Roadway Signing	110,797	-	110,797	110,797
T5643	Pavement Marking	127,351	-	114,755	114,755
T5643	Roadway Signing	20,400	-	20,400	20,400
T3751	Roadway Signing	7,095	-	7,095	7,095
E7M37	Roadway Signing	198,756	-	198,756	198,756
E7M37	Roadway Signing	-	-	14,005	14,005
T2591	Pavement Marking	402,235	-	265,013	265,013
T2749	Pavement Marking	145,352	-	135,991	135,991
E2U39	Pavement Marking	217,509	-	85,073	85,073
E5Z86	Roadway Signing	174,910	-	174,910	174,910
T7424	Pavement Marking	211,217	-	191,377	191,377
E2Z23	Pavement Marking	176,768	-	163,314	163,314
T2757	Pavement Marking	395,259	-	370,670	370,670
T4546	Roadway Signing	15,560	-	15,560	15,560
T3618	Roadway Signing	100,100	-	100,100	100,100
E2X67	Pavement Marking	250,900	-	176,321	176,321
E8S11	Pavement Marking	429,788	-	308,915	308,915
E8S11	Roadway Signing	547,350	-	413,608	413,608
T3763	Roadway Signing	47,145	-	7,525	7,525
T1754	Roadway Signing	102,930	-	102,930	102,930
T1754	Pavement Marking	804,177	-	705,278	705,278
T2772	Pavement Marking	62,779	-	46,788	46,788
T2772	Roadway Signing	4,950	-	4,950	4,950
E2Y83	Pavement Marking	44,993	-	44,993	44,993
T2787	Roadway Signing	44,999	-	25,287	25,287
T4544	Roadway Signing	248,995	-	248,995	248,995
T5686	Roadway Signing	107,870	-	107,870	107,870
T2771	Pavement Marking	261,022	-	197,223	197,223
T3359	Roadway Signing	113,755	-	107,535	107,535
E8R82	Roadway Signing	645,530	-	645,530	645,530
T7444	Roadway Signing	36,085	-	36,085	36,085
T7444	Pavement Marking	53,889	-	53,889	53,889
T1782	Roadway Signing	336,565	-	336,565	336,565
T1782	Pavement Marking	310,194	-	295,742	295,742
T1774	Roadway Signing	95,545	-	95,545	95,545

T1774	Pavement Marking	168,545	-	322,040	322,040
E8S32	Pavement Marking	377,279	-	333,078	333,078
E8S55	Roadway Signing	170,000	-	170,000	170,000
T5699	Roadway Signing	82,165	-	82,165	82,165
E51A5	Roadway Signing	41,400	-	41,400	41,400
E51A5	Pavement Marking	317,155	-	312,267	312,267
T2781	Roadway Signing	57,650	-	57,650	57,650
E3S76	Roadway Signing	255,000	-	255,000	255,000
E52A2	Roadway Signing	34,890	-	34,890	34,890
T1760	Roadway Signing	89,275	-	71,600	71,600
E5Z93	Roadway Signing	59,945	-	59,945	59,945
T2794	Pavement Marking	188,720	-	156,441	156,441
E6K68	Roadway Signing	-	-	(11,111)	(11,111)
T2788	Roadway Signing	-	-	15,000	15,000
T5711	Roadway Signing	97,365	-	97,365	97,365
E54A0	Roadway Signing	11,400	-	11,400	11,400
T2785	Roadway Signing	35,500	-	35,500	35,500
T2779	Roadway Signing	36,000	-	36,000	36,000
T3740	Roadway Signing	39,995	-	39,995	39,995
T7445	Roadway Signing	219,850	-	219,850	219,850
T7445	Pavement Marking	311,629	-	296,011	296,011
T5704	Pavement Marking	18,981	-	18,981	18,981
T2799	Pavement Marking	7,090	-	810	810
T2816	Pavement Marking	24,103	-	24,103	24,103
E51A3	Pavement Marking	7,550	-	7,550	7,550
E51A3	Roadway Signing	117,675	-	(25,565)	(25,565)
E51A3	Roadway Signing		-	(50,563)	(50,563)
T2757	Pavement Marking	395,260	-	394,992	394,992
T3760	Roadway Signing	10,100	-	10,100	10,100
T7448	Roadway Signing	6,435	-	6,435	6,435
T7448	Pavement Marking	33,253	-	32,429	32,429
T1065	Roadway Signing	331,850	-	331,850	331,850
T1065	Pavement Marking	438,815	-	407,264	407,264
T5743	Roadway Signing	76,025	-	76,025	76,025
T3769	Roadway Signing	7,300	-	7,300	7,300

T4560	Roadway Signing	12,180	-	12,180	12,180
T4560	Pavement Marking	9,267	-	9,267	9,267
T3787	Roadway Signing	60,725	-	60,725	60,725
T7456	Roadway Signing	77,971	-	77,971	77,971
T2793	Roadway Signing	44,250	-	44,250	44,250
E8566	Pavement Marking	839,579	-	839,579	839,579
T2803	Pavement Marking	177,565	-	177,565	177,565
E1R87	Roadway Signing	419,900	-	419,900	419,900
T3752	Roadway Signing	11,885	-	11,885	11,885
E3T55	Roadway Signing	32,925	-	32,925	32,925
T2804	Roadway Signing	30,740	-	30,740	30,740
T2793	Roadway Signing	44,250.00	-	44,250	44,250
E3U25	Roadway Signing	8,150.00	-	8,150	8,150
E8Q95	Roadway Signing	664,397	-	664,397	664,397
E8Q95	Pavement Marking	626,919	-	626,919	626,919
E8565	Pavement Marking	366,573	-	359,377	359,377
E8565	Roadway Signing	267,895	-	267,895	267,895
T7410	Roadway Signing	131,667	-	131,667	131,667
T7410	Pavement Marking	301,641	-	225,698	225,698
T1747	Roadway Signing	80,000	-	80,000	80,000
T1747	Pavement Marking	210,000	-	210,000	210,000
T2790	Roadway Signing	49,240	-	49,240	49,240
T3664	Roadway Signing	4,000	-	4,000	4,000
T7402	Pavement Marking	170,227	-	170,227	170,227
T3766	Roadway Signing	410,000	-	410,000	410,000
E3U53	Roadway Signing	36,100	-	36,100	36,100

DBE Utilization

The Department began its DBE race neutral program January 1, 2000. **Contract specific goals are not placed on Federal/State contracts**; however, the Department has an overall 10.65% DBE goal it must achieve. In order to assist contractors in determining their DBE commitment level, the Department has reviewed the estimates for this letting.

As you prepare your bid, please monitor potential or anticipated DBE utilization for contracts. When the low bidder executes the contract with the Department, information will be requested of the contractor's DBE participation for the project. While the utilization is not mandatory in order to be awarded the project, continuing utilization of DBE firms on contracts supports the success of Florida's DBE Program, and supports contractors' Equal Employment Opportunity and DBE Affirmative Action Programs.

Any project listed as 0% DBE availability does not mean that a DBE may not be used on that project. A 0% DBE availability may have been established due to any of the following reasons: limited identified subcontracting opportunities, minimal contract days, and/or small contract dollar amount. Contractors are encouraged to identify any opportunities to subcontract to DBE's.

Please contact the Equal Opportunity Office at (850) 414-4747 if you have any questions regarding this information.

DBE Reporting

If you are the prime contractor on a project, enter your DBE participation in the Equal Opportunity Compliance system prior to the pre-construction or pre-work conference for all federal and state funded projects. This **will not** become a mandatory part of the contract. It will assist the Department in tracking and reporting planned or estimated DBE utilization. During the contract, the prime contractor is required to report actual payments to DBE and MBE subcontractors through the web-based Equal Opportunity Compliance (EOC) system.

All DBE payments must be reported whether or not you initially planned to utilize the company. In order for our race neutral DBE Program to be successful, your cooperation is imperative. If you have any questions, please contact EOOHelp@dot.state.fl.us.

Bid Opportunity List

The Federal DBE Program requires States to maintain a database of all firms that are participating or attempting to participate on FDOT-assisted contracts. The list must include all firms that bid on prime contracts or bid or quote subcontracts on FDOT-assisted projects, including both **DBE's and non-DBE's**.

Please complete the Bidders Opportunity List through the Equal Opportunity Compliance system within 3 business days of submission of the bid or proposal for ALL subcontractors or sub-consultants who quoted to you for specific project for this letting. The web address to the Equal Opportunity Compliance system is: <https://www.fdot.gov/equalopportunity/eoc.shtm>.

The prospective participant certifies, by signing this certification, that to the best of his or her knowledge and belief:

(1) No federal appropriated funds have been paid or will be paid, by or on behalf of the undersigned, to any person for influencing or attempting to influence an officer or employee of any federal agency, a Member of Congress, an officer or employee of Congress, or an employee of a Member of Congress in connection with the awarding of any federal contract, the making of any federal grant, the making of any federal loan, the entering into of any cooperative agreement, and the extension, continuation, renewal, amendment, or modification of any federal contract, grant, loan, or cooperative agreement.

(2) If any funds other than federal appropriated funds have been paid or will be paid to any person for influencing or attempting to influence an officer or employee of any federal agency, a Member of Congress, an officer or employee of Congress, or an employee of a Member of Congress in connection with this federal contract, grant, loan, or cooperative agreement, the undersigned shall complete and submit Standard Form-LLL, "Disclosure of Lobbying Activities", in accordance with its instructions. (Standard Form-LLL can be obtained from the Florida Department of Transportation's Professional Services Administrator or Procurement Office.)

This certification is a material representation of fact upon which reliance was placed when this transaction was made or entered into. Submission of this certification is a prerequisite for making or entering into this transaction imposed by Section 1352, Title 31, U.S. Code. Any person who fails to file the required certification shall be subject to a civil penalty of not less than \$10,000 and not more than \$100,000 for each such failure.

The prospective participant also agrees by submitting his or her proposal that he or she shall require that the language of this certification be included in all lower tier subcontracts, which exceed \$100,000 and that all such subrecipients shall certify and disclose accordingly.

Name of Consultant: ACME Barricades, L.C.
By: Christian Cummings Date: 12/20/2021
Authorized Signature: 
Title: CEO

STATE OF FLORIDA DEPARTMENT OF TRANSPORTATION
DISCLOSURE OF LOBBYING ACTIVITIES

375-030-34
 PROCUREMENT
 02/16

Is this form applicable to your firm?

YES NO

If no, then please complete section 4 below for "Prime"

1. Type of Federal Action: a. contract b. grant c. cooperative agreement d. loan e. loan guarantee f. loan insurance	2. Status of Federal Action: a. bid/offer/application b. initial award c. post-award	3. Report Type: a. initial filing b. material change For Material Change Only: Year: _____ Quarter: _____ Date of last report: _____ (mm/dd/yyyy)
4. Name and Address of Reporting Entity: <input checked="" type="checkbox"/> Prime <input type="checkbox"/> Subawardee Tier _____, if known: <u>ACME Barricades, L.C.</u> <u>9800 Normandy Blvd</u> <u>Jacksonville, FL 32221</u>		5. If Reporting Entity in No. 4 is a Subawardee, Enter Name and Address of Prime: _____ _____ _____ Congressional District, if known: _____
6. Federal Department/Agency: _____ _____	7. Federal Program Name/Description: _____ _____ CFDA Number, if applicable: _____	
8. Federal Action Number, if known: _____	9. Award Amount, if known: \$ _____	
10. a. Name and Address of Lobbying Registrant (if individual, last name, first name, MI): _____ _____ _____	b. Individuals Performing Services (including address if different from No. 10a) (last name, first name, MI): _____ _____ _____	
11. Information requested through this form is authorized by title 31 U.S.C. section 1352. This disclosure of lobbying activities is a material representation of fact upon which reliance was placed by the tier above when this transaction was made or entered into. This disclosure is required pursuant to 31 U.S.C. 1352. This information will be available for public inspection. Any person who fails to file the required disclosure shall be subject to a civil penalty of not less than \$10,000 and not more than \$100,000 for each such failure.	Signature: <u></u> Print Name: <u>Christian Cummings</u> Title: <u>CEO</u> Telephone No. <u>904-781-950</u> Date (mm/dd/yyyy): <u>12/20/2021</u>	
Federal Use Only:		Authorized for Local Reproduction Standard Form LLL (Rev. 7-97)

INSTRUCTIONS FOR COMPLETION OF SF-LLL, DISCLOSURE OF LOBBYING ACTIVITIES

This disclosure form shall be completed by the reporting entity, whether subawardee or prime Federal recipient, at the initiation or receipt of a covered Federal action, or a material change to a previous filing, pursuant to title 31 U.S.C. section 1352. The filing of a form is required for each payment or agreement to make payment to any lobbying entity for influencing or attempting to influence an officer or employee of any agency, a Member of Congress, an officer or employee of Congress, or an employee of a Member of Congress in connection with a covered Federal action. Complete all items that apply for both the initial filing and material change report. Refer to the implementing guidance published by the Office of Management and Budget for additional information.

1. Identify the type of covered Federal action for which lobbying activity is and/or has been secured to influence the outcome of a covered Federal action.
2. Identify the status of the covered Federal action.
3. Identify the appropriate classification of this report. If this is a followup report caused by a material change to the information previously reported, enter the year and quarter in which the change occurred. Enter the date of the last previously submitted report by this reporting entity for this covered Federal action.
4. Enter the fullname, address, city, State and zip code of the reporting entity. Include Congressional District, if known. Check the appropriate classification of the reporting entity that designates if it is, or expects to be, a prime or subaward recipient. Identify the tier of the subawardee, e.g., the first subawardee of the prime is the 1st tier. Subawards include but are not limited to subcontracts, subgrants and contract awards under grants.
5. If the organization filing the report in item 4 checks "Subawardee," then enter the full name, address, city, State and zip code of the prime Federal recipient. Include Congressional District, if known.
6. Enter the name of the Federal agency making the award or loan commitment. Include at least one organizational level below agency name, if known. For example, Department of Transportation, United States Coast Guard.
7. Enter the Federal program name or description for the covered Federal action (item 1). If known, enter the full Catalog of Federal Domestic Assistance (CFDA) number for grants, cooperative agreements, loans, and loan commitments.
8. Enter the most appropriate Federal identifying number available for the Federal action identified in item 1 (e.g., Request for Proposal (RFP) number; Invitation for Bid (IFB) number; grant announcement number; the contract, grant, or loan award number; the application/proposal control number assigned by the Federal agency). Include prefixes, e.g., "RFP-DE-90-001."
9. For a covered Federal action where there has been an award or loan commitment by the Federal agency, enter the Federal amount of the award/loan commitment for the prime entity identified in item 4 or 5.
10. (a) Enter the full name, address, city, State and zip code of the lobbying registrant under the Lobbying Disclosure Act of 1995 engaged by the reporting entity identified in item 4 to influence the covered Federal action.

(b) Enter the full names of the individual(s) performing services, and include full address if different from 10 (a). Enter Last Name, First Name, and Middle Initial (MI).
11. The certifying official shall sign and date the form, print his/her name, title, and telephone number.

According to the Paperwork Reduction Act, as amended, no persons are required to respond to a collection of information unless it displays a valid OMB Control Number. The valid OMB control number for this information collection is OMB No. 0348-0046. Public reporting burden for this collection of information is estimated to average 10 minutes per response, including time for reviewing instructions, searching existing data sources, gathering and maintaining the data needed, and completing and reviewing the collection of information. Send comments regarding the burden estimate or any other aspect of this collection of information, including suggestions for reducing this burden, to the Office of Management and Budget, Paperwork Reduction Project (0348-0046), Washington, DC 20503.

STATE OF FLORIDA DEPARTMENT OF TRANSPORTATION
NON-COLLUSION DECLARATION AND
COMPLIANCE WITH 49 CFR § 29

575-060-13
RIGHT OF WAY
05/01
Page 1 of 3

ITEM/SEGMENT NO.: _____
F.A.P. NO.: _____
MANAGING DISTRICT: NASSAU COUNTY DISTRICT
PARCEL NO.: _____
COUNTY OF: NASSAU
BID LETTING OF: 12/21/2021

I, Christian Cummings (NAME) hereby declare that I am
CEO (TITLE) of ACME Barricades, L.C. (FIRM)
of Jacksonville, Florida (CITY AND STATE)

and that I am the person responsible within my firm for the final decision as to the price(s) and amount of this Bid on this State Project.

I further declare that:

1. The prices(s) and amount of this bid have been arrived at independently, without consultation, communication or agreement, for the purpose of restricting competition with any other contractor, bidder or potential bidder.
2. Neither the price(s) nor the amount of this bid have been disclosed to any other firm or person who is a bidder or potential bidder on this project, and will not be so disclosed prior to the bid opening.
3. No attempt has been made or will be made to solicit, cause or induce any other firm or person to refrain from bidding on this project, or to submit a bid higher than the bid of this firm, or any intentionally high or non-competitive bid or other form of complementary bid.
4. The bid of my firm is made in good faith and not pursuant to any agreement or discussion with, or inducement from, any firm or person to submit a complementary bid.
5. My firm has not offered or entered into a subcontract or agreement regarding the purchase of materials or services from any firm or person, or offered, promised or paid cash or anything of value to any firm or person, whether in connection with this or any other project, in consideration for an agreement or promise by any firm or person to refrain from bidding or to submit a complementary bid on this project.
6. My firm has not accepted or been promised any subcontract or agreement regarding the sale of materials or services to any firm or person, and has not been promised or paid cash or anything of value by any firm or person, whether in connection with this or any other project, in consideration for my firm's submitting a complementary bid, or agreeing to do so, on this project.
7. I have made a diligent inquiry of all members, officers, employees, and agents of my firm with responsibilities relating to the preparation, approval or submission of my firm's bid on this project and have been advised by each of them that he or she has not participated in any communication, consultation, discussion, agreement, collusion, act or other conduct inconsistent with any of the statements and representations made in this Declaration.
8. As required by Section 337.165, Florida Statutes, the firm has fully informed the Department of Transportation in writing of all convictions of the firm, its affiliates (as defined in Section 337.165(1)(a), Florida Statutes), and all directors, officers, and employees of the firm and its affiliates for violation of state or federal antitrust laws with respect to a public contract or for violation of any state or federal law involving fraud, bribery, collusion, conspiracy or material misrepresentation with respect to a public contract. This includes disclosure of the names of current employees of the firm or affiliates who were convicted of contract crimes while in the employ of another company.

9. I certify that, except as noted below, neither my firm nor any person associated therewith in the capacity of owner, partner, director, officer, principal, investigator, project director, manager, auditor, and/or position involving the administration of Federal funds:

(a) is presently debarred, suspended, proposed for debarment, declared ineligible, or voluntarily excluded from covered transactions, as defined in 49 CFR §29.110(a), by any Federal department or agency;

(b) has within a three-year period preceding this certification been convicted of or had a civil judgment rendered against him or her for: commission of fraud or a criminal offense in connection with obtaining, attempting to obtain, or performing a Federal, State or local government transaction or public contract; violation of Federal or State antitrust statutes; or commission of embezzlement, theft, forgery, bribery, falsification or destruction of records, making false statements or receiving stolen property;

(c) is presently indicted for or otherwise criminally or civilly charged by a Federal, State or local governmental entity with commission of any of the offenses enumerated in paragraph 9(b) of this certification; and

(d) has within a three-year period preceding this certification had one or more Federal, State or local government public transactions terminated for cause or default.

10. I(We), certify that I(We), shall not knowingly enter into any transaction with any subcontractor, material supplier, or vendor who is debarred, suspended, declared ineligible, or voluntarily excluded from participation in this contract by any Federal Agency unless authorized by the Department.

Where I am unable to declare or certify as to any of the statements contained in the above stated paragraphs numbered (1) through (10), I have provided an explanation in the "Exceptions" portion below or by attached separate sheet.

EXCEPTIONS:

(Any exception listed above will not necessarily result in denial of award, but will be considered in determining bidder responsibility. For any exception noted, indicate to whom it applies, initiating agency and dates of agency action. Providing false information may result in criminal prosecution and/or administrative sanctions.)

I declare under penalty of perjury that the foregoing is true and correct.

CONTRACTOR: (Seal)

BY: Christian Cummings, LSU
NAME AND TITLE PRINTED

WITNESS: [Signature]

BY: [Signature]
SIGNATURE

WITNESS: [Signature]

Executed on this 20 day of December, 2021

**FAILURE TO FULLY COMPLETE AND EXECUTE THIS DOCUMENT
MAY RESULT IN THE BID BEING DECLARED NONRESPONSIVE**

REQUIRED CONTRACT PROVISIONS

This certification applies to subcontractors, material suppliers, vendors and other lower tier participants.

- Appendix B of 49 CFR Part 29 -

Appendix B—Certification Regarding Debarment, Suspension, Ineligibility and Voluntary Exclusion—Lower Tier Covered Transactions

Instructions for Certification

1. By signing and submitting this proposal, the prospective lower tier participant is providing the certification set out below.
2. The certification in this clause is a material representation of fact upon which reliance was placed when this transaction was entered. If it is later determined that the prospective lower tier participant knowingly rendered an erroneous certification, in addition to other remedies available to the Federal Government, the department or agency with which this transaction originated may pursue available remedies, including suspension and/or debarment.
3. The prospective lower tier participant shall provide immediate written notice to the person to which this proposal is submitted if at any time the prospective lower tier participant learns that its certification was erroneous when submitted or has become erroneous by reason of changed circumstances.
4. The terms "covered transaction," "debarred," "suspended," "ineligible," "lower tier covered transaction," "participant," "person," "primary covered transaction," "principal," "proposal," and "voluntarily excluded," as used in this clause, have the meanings set out in the Definitions and Coverage sections of rules implementing Executive Order 12549. You may contact the person to whom this proposal is submitted for assistance in obtaining a copy of those regulations.
5. The prospective lower tier participant agrees by submitting this proposal that it shall not knowingly enter into any lower tier covered transaction with a person who is debarred, suspended, declared ineligible, or voluntarily excluded from participation in this covered transaction, unless authorized by the department or agency with which this transaction originated.
6. The prospective lower tier participant further agrees by submitting this proposal that it will include this clause titled "Certification Regarding Debarment, Suspension, Ineligibility and Voluntary Exclusion—Lower Tier Covered Transaction," without modification, in all lower tier covered transactions and in all solicitations for lower tier covered transactions.
7. A participant in a covered transaction may rely upon a certification of a prospective participant in a lower tier covered transaction that it is not debarred, suspended, ineligible, or voluntarily excluded from the covered transaction, unless it knows that the certification is erroneous. A participant may decide the method and frequency by which it determines the eligibility of its principals. Each participant may, but is not required to, check the Nonprocurement List.
8. Nothing contained in the foregoing shall be construed to require establishment of a system of records in order to render in good faith the certification required by this clause. The knowledge and information of a participant is not required to exceed that which is normally possessed by a prudent person in the ordinary course of business dealings.
9. Except for transactions authorized under paragraph 5 of these instructions, if a participant in a covered transaction knowingly enters into a lower tier covered transaction with a person who is suspended, debarred, ineligible, or voluntarily excluded from participation in this transaction, in addition to other remedies available to the Federal Government, the department or agency with which this transaction originated may pursue available remedies, including suspension and/or debarment.

Certification Regarding Debarment, Suspension, Ineligibility and Voluntary Exclusion—Lower Tier Covered Transactions

- (1) The prospective lower tier participant certifies, by submission of this proposal, that neither it nor its principals is presently debarred, suspended, proposed for debarment, declared ineligible, or voluntarily excluded from participation in this transaction by any Federal department or agency.
- (2) Where the prospective lower tier participant is unable to certify to any of the statements in this certification, such prospective participant shall attach an explanation to this proposal.

STATE OF FLORIDA DEPARTMENT OF TRANSPORTATION
**CERTIFICATION REGARDING DEBARMENT, SUSPENSION,
 INELIGIBILITY AND VOLUNTARY EXCLUSION-
 LOWER TIER COVERED TRANSACTIONS FOR FEDERAL AID CONTRACTS**
 (Compliance with 2 CFR Parts 180 and 1200)

375-030-32
 PROCUREMENT
 11/15

It is certified that neither the below identified firm nor its principals are presently suspended, proposed for debarment, declared ineligible, or voluntarily excluded from participation in this transaction by any federal department or agency.

Name of Consultant/Contractor: Acme Berricudey, LLC
 By: [Signature]
 Date: 12/20/20
 Title: CEO

Instructions for Certification

Instructions for Certification - Lower Tier Participants:

(Applicable to all subcontracts, purchase orders and other lower tier transactions requiring prior FHWA approval or estimated to cost \$25,000 or more - 2 CFR Parts 180 and 1200)

- a. By signing and submitting this proposal, the prospective lower tier is providing the certification set out below.
- b. The certification in this clause is a material representation of fact upon which reliance was placed when this transaction was entered into. If it is later determined that the prospective lower tier participant knowingly rendered an erroneous certification, in addition to other remedies available to the Federal Government, the department, or agency with which this transaction originated may pursue available remedies, including suspension and/or debarment.
- c. The prospective lower tier participant shall provide immediate written notice to the person to which this proposal is submitted if at any time the prospective lower tier participant learns that its certification was erroneous by reason of changed circumstances.
- d. The terms "covered transaction," "debarred," "suspended," "ineligible," "participant," "person," "principal," and "voluntarily excluded," as used in this clause, are defined in 2 CFR Parts 180 and 1200. You may contact the person to which this proposal is submitted for assistance in obtaining a copy of those regulations. "First Tier Covered Transactions" refers to any covered transaction between a grantee or subgrantee of Federal funds and a participant (such as the prime or general contract). "Lower Tier Covered Transactions" refers to any covered transaction under a First Tier Covered Transaction (such as subcontracts). "First Tier Participant" refers to the participant who has entered into a covered transaction with a grantee or subgrantee of Federal funds (such as the prime or general contractor). "Lower Tier Participant" refers any participant who has entered into a covered transaction with a First Tier Participant or other Lower Tier Participants (such as subcontractors and suppliers).
- e. The prospective lower tier participant agrees by submitting this proposal that, should the proposed covered transaction be entered into, it shall not knowingly enter into any lower tier covered transaction with a person who is debarred, suspended, declared ineligible, or voluntarily excluded from participation in this covered transaction, unless authorized by the department or agency with which this transaction originated.
- f. The prospective lower tier participant further agrees by submitting this proposal that it will include this clause titled "Certification Regarding Debarment, Suspension, Ineligibility and Voluntary Exclusion-Lower Tier Covered Transaction," without modification, in all lower tier covered transactions and in all solicitations for lower tier covered transactions exceeding the \$25,000 threshold.
- g. A participant in a covered transaction may rely upon a certification of a prospective participant in a lower tier covered transaction that is not debarred, suspended, ineligible, or voluntarily excluded from the covered transaction, unless it knows that the certification is erroneous. A participant is responsible for ensuring that its principals are not suspended, debarred, or otherwise ineligible to participate in covered transactions. To verify the eligibility of its principals, as well as the eligibility of any lower tier prospective participants, each participant may, but is not required to, check the Excluded Parties List System website (<https://www.epls.gov/>), which is compiled by the General Services Administration.
- h. Nothing contained in the foregoing shall be construed to require establishment of a system of records in order to render in good faith the certification required by this clause. The knowledge and information of participant is not required to exceed that which is normally possessed by a prudent person in the ordinary course of business dealings.
- i. Except for transactions authorized under paragraph e of these instructions, if a participant in a covered transaction knowingly enters into a lower tier covered transaction with a person who is suspended, debarred, ineligible, or voluntarily excluded from participation in this transaction, in addition to other remedies available to the Federal Government, the department or agency with which this transaction originated may pursue available remedies, including suspension and/or debarment.

**REQUIRED CONTRACT PROVISIONS
FEDERAL-AID CONSTRUCTION CONTRACTS**

- I. General
- II. Nondiscrimination
- III. Nonsegregated Facilities
- IV. Davis-Bacon and Related Act Provisions
- V. Contract Work Hours and Safety Standards Act Provisions
- VI. Subletting or Assigning the Contract
- VII. Safety: Accident Prevention
- VIII. False Statements Concerning Highway Projects
- IX. Implementation of Clean Air Act and Federal Water Pollution Control Act
- X. Compliance with Governmentwide Suspension and Debarment Requirements
- XI. Certification Regarding Use of Contract Funds for Lobbying

ATTACHMENTS

A. Employment and Materials Preference for Appalachian Development Highway System or Appalachian Local Access Road Contracts (included in Appalachian contracts only)

I. GENERAL

1. Form FHWA-1273 must be physically incorporated in each construction contract funded under Title 23 (excluding emergency contracts solely intended for debris removal). The contractor (or subcontractor) must insert this form in each subcontract and further require its inclusion in all lower tier subcontracts (excluding purchase orders, rental agreements and other agreements for supplies or services).

The applicable requirements of Form FHWA-1273 are incorporated by reference for work done under any purchase order, rental agreement or agreement for other services. The prime contractor shall be responsible for compliance by any subcontractor, lower-tier subcontractor or service provider.

Form FHWA-1273 must be included in all Federal-aid design-build contracts, in all subcontracts and in lower tier subcontracts (excluding subcontracts for design services, purchase orders, rental agreements and other agreements for supplies or services). The design-builder shall be responsible for compliance by any subcontractor, lower-tier subcontractor or service provider.

Contracting agencies may reference Form FHWA-1273 in bid proposal or request for proposal documents, however, the Form FHWA-1273 must be physically incorporated (not referenced) in all contracts, subcontracts and lower-tier subcontracts (excluding purchase orders, rental agreements and other agreements for supplies or services related to a construction contract).

2. Subject to the applicability criteria noted in the following sections, these contract provisions shall apply to all work performed on the contract by the contractor's own organization and with the assistance of workers under the contractor's immediate superintendence and to all work performed on the contract by piecework, station work, or by subcontract.

3. A breach of any of the stipulations contained in these Required Contract Provisions may be sufficient grounds for withholding of progress payments, withholding of final payment, termination of the contract, suspension / debarment or any other action determined to be appropriate by the contracting agency and FHWA.

4. Selection of Labor: During the performance of this contract, the contractor shall not use convict labor for any purpose within the limits of a construction project on a Federal-aid highway unless it is labor performed by convicts who are on parole, supervised release, or probation. The term Federal-aid highway does not include roadways functionally classified as local roads or rural minor collectors.

II. NONDISCRIMINATION

The provisions of this section related to 23 CFR Part 230 are applicable to all Federal-aid construction contracts and to all related construction subcontracts of \$10,000 or more. The provisions of 23 CFR Part 230 are not applicable to material supply, engineering, or architectural service contracts.

In addition, the contractor and all subcontractors must comply with the following policies: Executive Order 11246, 41 CFR 60, 29 CFR 1625-1627, Title 23 USC Section 140, the Rehabilitation Act of 1973, as amended (29 USC 794), Title VI of the Civil Rights Act of 1964, as amended, and related regulations including 49 CFR Parts 21, 26 and 27; and 23 CFR Parts 200, 230, and 633.

The contractor and all subcontractors must comply with: the requirements of the Equal Opportunity Clause in 41 CFR 60-1.4(b) and, for all construction contracts exceeding \$10,000, the Standard Federal Equal Employment Opportunity Construction Contract Specifications in 41 CFR 60-4.3.

Note: The U.S. Department of Labor has exclusive authority to determine compliance with Executive Order 11246 and the policies of the Secretary of Labor including 41 CFR 60, and 29 CFR 1625-1627. The contracting agency and the FHWA have the authority and the responsibility to ensure compliance with Title 23 USC Section 140, the Rehabilitation Act of 1973, as amended (29 USC 794), and Title VI of the Civil Rights Act of 1964, as amended, and related regulations including 49 CFR Parts 21, 26 and 27; and 23 CFR Parts 200, 230, and 633.

The following provision is adopted from 23 CFR 230, Appendix A, with appropriate revisions to conform to the U.S. Department of Labor (US DOL) and FHWA requirements.

1. Equal Employment Opportunity: Equal employment opportunity (EEO) requirements not to discriminate and to take affirmative action to assure equal opportunity as set forth under laws, executive orders, rules, regulations (28 CFR 35, 29 CFR 1630, 29 CFR 1625-1627, 41 CFR 60 and 49 CFR 27) and orders of the Secretary of Labor as modified by the provisions prescribed herein, and imposed pursuant to 23 U.S.C. 140 shall constitute the EEO and specific affirmative action standards for the contractor's project activities under

this contract. The provisions of the Americans with Disabilities Act of 1990 (42 U.S.C. 12101 et seq.) set forth under 28 CFR 35 and 29 CFR 1630 are incorporated by reference in this contract. In the execution of this contract, the contractor agrees to comply with the following minimum specific requirement activities of EEO:

a. The contractor will work with the contracting agency and the Federal Government to ensure that it has made every good faith effort to provide equal opportunity with respect to all of its terms and conditions of employment and in their review of activities under the contract.

b. The contractor will accept as its operating policy the following statement:

"It is the policy of this Company to assure that applicants are employed, and that employees are treated during employment, without regard to their race, religion, sex, color, national origin, age or disability. Such action shall include: employment, upgrading, demotion, or transfer; recruitment or recruitment advertising; layoff or termination; rates of pay or other forms of compensation; and selection for training, including apprenticeship, pre-apprenticeship, and/or on-the-job training."

2. EEO Officer: The contractor will designate and make known to the contracting officers an EEO Officer who will have the responsibility for and must be capable of effectively administering and promoting an active EEO program and who must be assigned adequate authority and responsibility to do so.

3. Dissemination of Policy: All members of the contractor's staff who are authorized to hire, supervise, promote, and discharge employees, or who recommend such action, or who are substantially involved in such action, will be made fully cognizant of, and will implement, the contractor's EEO policy and contractual responsibilities to provide EEO in each grade and classification of employment. To ensure that the above agreement will be met, the following actions will be taken as a minimum:

a. Periodic meetings of supervisory and personnel office employees will be conducted before the start of work and then not less often than once every six months, at which time the contractor's EEO policy and its implementation will be reviewed and explained. The meetings will be conducted by the EEO Officer.

b. All new supervisory or personnel office employees will be given a thorough indoctrination by the EEO Officer, covering all major aspects of the contractor's EEO obligations within thirty days following their reporting for duty with the contractor.

c. All personnel who are engaged in direct recruitment for the project will be instructed by the EEO Officer in the contractor's procedures for locating and hiring minorities and women.

d. Notices and posters setting forth the contractor's EEO policy will be placed in areas readily accessible to employees, applicants for employment and potential employees.

e. The contractor's EEO policy and the procedures to implement such policy will be brought to the attention of employees by means of meetings, employee handbooks, or other appropriate means.

4. Recruitment: When advertising for employees, the contractor will include in all advertisements for employees the notation: "An Equal Opportunity Employer." All such advertisements will be placed in publications having a large circulation among minorities and women in the area from which the project work force would normally be derived.

a. The contractor will, unless precluded by a valid bargaining agreement, conduct systematic and direct recruitment through public and private employee referral sources likely to yield qualified minorities and women. To meet this requirement, the contractor will identify sources of potential minority group employees, and establish with such identified sources procedures whereby minority and women applicants may be referred to the contractor for employment consideration.

b. In the event the contractor has a valid bargaining agreement providing for exclusive hiring hall referrals, the contractor is expected to observe the provisions of that agreement to the extent that the system meets the contractor's compliance with EEO contract provisions. Where implementation of such an agreement has the effect of discriminating against minorities or women, or obligates the contractor to do the same, such implementation violates Federal nondiscrimination provisions.

c. The contractor will encourage its present employees to refer minorities and women as applicants for employment. Information and procedures with regard to referring such applicants will be discussed with employees.

5. Personnel Actions: Wages, working conditions, and employee benefits shall be established and administered, and personnel actions of every type, including hiring, upgrading, promotion, transfer, demotion, layoff, and termination, shall be taken without regard to race, color, religion, sex, national origin, age or disability. The following procedures shall be followed:

a. The contractor will conduct periodic inspections of project sites to insure that working conditions and employee facilities do not indicate discriminatory treatment of project site personnel.

b. The contractor will periodically evaluate the spread of wages paid within each classification to determine any evidence of discriminatory wage practices.

c. The contractor will periodically review selected personnel actions in depth to determine whether there is evidence of discrimination. Where evidence is found, the contractor will promptly take corrective action. If the review indicates that the discrimination may extend beyond the actions reviewed, such corrective action shall include all affected persons.

d. The contractor will promptly investigate all complaints of alleged discrimination made to the contractor in connection with its obligations under this contract, will attempt to resolve such complaints, and will take appropriate corrective action within a reasonable time. If the investigation indicates that the discrimination may affect persons other than the complainant, such corrective action shall include such other persons. Upon completion of each investigation, the contractor will inform every complainant of all of their avenues of appeal.

6. Training and Promotion:

a. The contractor will assist in locating, qualifying, and increasing the skills of minorities and women who are

applicants for employment or current employees. Such efforts should be aimed at developing full journey level status employees in the type of trade or job classification involved.

b. Consistent with the contractor's work force requirements and as permissible under Federal and State regulations, the contractor shall make full use of training programs, i.e., apprenticeship, and on-the-job training programs for the geographical area of contract performance. In the event a special provision for training is provided under this contract, this subparagraph will be superseded as indicated in the special provision. The contracting agency may reserve training positions for persons who receive welfare assistance in accordance with 23 U.S.C. 140(a).

c. The contractor will advise employees and applicants for employment of available training programs and entrance requirements for each.

d. The contractor will periodically review the training and promotion potential of employees who are minorities and women and will encourage eligible employees to apply for such training and promotion.

7. Unions: If the contractor relies in whole or in part upon unions as a source of employees, the contractor will use good faith efforts to obtain the cooperation of such unions to increase opportunities for minorities and women. Actions by the contractor, either directly or through a contractor's association acting as agent, will include the procedures set forth below:

a. The contractor will use good faith efforts to develop, in cooperation with the unions, joint training programs aimed toward qualifying more minorities and women for membership in the unions and increasing the skills of minorities and women so that they may qualify for higher paying employment.

b. The contractor will use good faith efforts to incorporate an EEO clause into each union agreement to the end that such union will be contractually bound to refer applicants without regard to their race, color, religion, sex, national origin, age or disability.

c. The contractor is to obtain information as to the referral practices and policies of the labor union except that to the extent such information is within the exclusive possession of the labor union and such labor union refuses to furnish such information to the contractor, the contractor shall so certify to the contracting agency and shall set forth what efforts have been made to obtain such information.

d. In the event the union is unable to provide the contractor with a reasonable flow of referrals within the time limit set forth in the collective bargaining agreement, the contractor will, through independent recruitment efforts, fill the employment vacancies without regard to race, color, religion, sex, national origin, age or disability; making full efforts to obtain qualified and/or qualifiable minorities and women. The failure of a union to provide sufficient referrals (even though it is obligated to provide exclusive referrals under the terms of a collective bargaining agreement) does not relieve the contractor from the requirements of this paragraph. In the event the union referral practice prevents the contractor from meeting the obligations pursuant to Executive Order 11246, as amended, and these special provisions, such contractor shall immediately notify the contracting agency.

8. Reasonable Accommodation for Applicants / Employees with Disabilities: The contractor must be familiar

with the requirements for and comply with the Americans with Disabilities Act and all rules and regulations established there under. Employers must provide reasonable accommodation in all employment activities unless to do so would cause an undue hardship.

9. Selection of Subcontractors, Procurement of Materials and Leasing of Equipment: The contractor shall not discriminate on the grounds of race, color, religion, sex, national origin, age or disability in the selection and retention of subcontractors, including procurement of materials and leases of equipment. The contractor shall take all necessary and reasonable steps to ensure nondiscrimination in the administration of this contract.

a. The contractor shall notify all potential subcontractors and suppliers and lessors of their EEO obligations under this contract.

b. The contractor will use good faith efforts to ensure subcontractor compliance with their EEO obligations.

10. Assurance Required by 49 CFR 26.13(b):

a. The requirements of 49 CFR Part 26 and the State DOT's U.S. DOT-approved DBE program are incorporated by reference.

b. The contractor or subcontractor shall not discriminate on the basis of race, color, national origin, or sex in the performance of this contract. The contractor shall carry out applicable requirements of 49 CFR Part 26 in the award and administration of DOT-assisted contracts. Failure by the contractor to carry out these requirements is a material breach of this contract, which may result in the termination of this contract or such other remedy as the contracting agency deems appropriate.

11. Records and Reports: The contractor shall keep such records as necessary to document compliance with the EEO requirements. Such records shall be retained for a period of three years following the date of the final payment to the contractor for all contract work and shall be available at reasonable times and places for inspection by authorized representatives of the contracting agency and the FHWA.

a. The records kept by the contractor shall document the following:

(1) The number and work hours of minority and non-minority group members and women employed in each work classification on the project;

(2) The progress and efforts being made in cooperation with unions, when applicable, to increase employment opportunities for minorities and women; and

(3) The progress and efforts being made in locating, hiring, training, qualifying, and upgrading minorities and women;

b. The contractors and subcontractors will submit an annual report to the contracting agency each July for the duration of the project, indicating the number of minority, women, and non-minority group employees currently engaged in each work classification required by the contract work. This information is to be reported on Form FHWA-1391. The staffing data should represent the project work force on board in all or any part of the last payroll period preceding the end of July. If on-the-job training is being required by special provision, the contractor

will be required to collect and report training data. The employment data should reflect the work force on board during all or any part of the last payroll period preceding the end of July.

III. NONSEGREGATED FACILITIES

This provision is applicable to all Federal-aid construction contracts and to all related construction subcontracts of \$10,000 or more.

The contractor must ensure that facilities provided for employees are provided in such a manner that segregation on the basis of race, color, religion, sex, or national origin cannot result. The contractor may neither require such segregated use by written or oral policies nor tolerate such use by employee custom. The contractor's obligation extends further to ensure that its employees are not assigned to perform their services at any location, under the contractor's control, where the facilities are segregated. The term "facilities" includes waiting rooms, work areas, restaurants and other eating areas, time clocks, restrooms, washrooms, locker rooms, and other storage or dressing areas, parking lots, drinking fountains, recreation or entertainment areas, transportation, and housing provided for employees. The contractor shall provide separate or single-user restrooms and necessary dressing or sleeping areas to assure privacy between sexes.

IV. DAVIS-BACON AND RELATED ACT PROVISIONS

This section is applicable to all Federal-aid construction projects exceeding \$2,000 and to all related subcontracts and lower-tier subcontracts (regardless of subcontract size). The requirements apply to all projects located within the right-of-way of a roadway that is functionally classified as Federal-aid highway. This excludes roadways functionally classified as local roads or rural minor collectors, which are exempt. Contracting agencies may elect to apply these requirements to other projects.

The following provisions are from the U.S. Department of Labor regulations in 29 CFR 5.5 "Contract provisions and related matters" with minor revisions to conform to the FHWA-1273 format and FHWA program requirements.

1. Minimum wages

a. All laborers and mechanics employed or working upon the site of the work, will be paid unconditionally and not less often than once a week, and without subsequent deduction or rebate on any account (except such payroll deductions as are permitted by regulations issued by the Secretary of Labor under the Copeland Act (29 CFR part 3)), the full amount of wages and bona fide fringe benefits (or cash equivalents thereof) due at time of payment computed at rates not less than those contained in the wage determination of the Secretary of Labor which is attached hereto and made a part hereof, regardless of any contractual relationship which may be alleged to exist between the contractor and such laborers and mechanics.

Contributions made or costs reasonably anticipated for bona fide fringe benefits under section 1(b)(2) of the Davis-Bacon Act on behalf of laborers or mechanics are considered wages paid to such laborers or mechanics, subject to the provisions

of paragraph 1.d. of this section; also, regular contributions made or costs incurred for more than a weekly period (but not less often than quarterly) under plans, funds, or programs which cover the particular weekly period, are deemed to be constructively made or incurred during such weekly period. Such laborers and mechanics shall be paid the appropriate wage rate and fringe benefits on the wage determination for the classification of work actually performed, without regard to skill, except as provided in 29 CFR 5.5(a)(4). Laborers or mechanics performing work in more than one classification may be compensated at the rate specified for each classification for the time actually worked therein: Provided, That the employer's payroll records accurately set forth the time spent in each classification in which work is performed. The wage determination (including any additional classification and wage rates conformed under paragraph 1.b. of this section) and the Davis-Bacon poster (WH-1321) shall be posted at all times by the contractor and its subcontractors at the site of the work in a prominent and accessible place where it can be easily seen by the workers.

b.(1) The contracting officer shall require that any class of laborers or mechanics, including helpers, which is not listed in the wage determination and which is to be employed under the contract shall be classified in conformance with the wage determination. The contracting officer shall approve an additional classification and wage rate and fringe benefits therefore only when the following criteria have been met:

(i) The work to be performed by the classification requested is not performed by a classification in the wage determination; and

(ii) The classification is utilized in the area by the construction industry; and

(iii) The proposed wage rate, including any bona fide fringe benefits, bears a reasonable relationship to the wage rates contained in the wage determination.

(2) If the contractor and the laborers and mechanics to be employed in the classification (if known), or their representatives, and the contracting officer agree on the classification and wage rate (including the amount designated for fringe benefits where appropriate), a report of the action taken shall be sent by the contracting officer to the Administrator of the Wage and Hour Division, Employment Standards Administration, U.S. Department of Labor, Washington, DC 20210. The Administrator, or an authorized representative, will approve, modify, or disapprove every additional classification action within 30 days of receipt and so advise the contracting officer or will notify the contracting officer within the 30-day period that additional time is necessary.

(3) In the event the contractor, the laborers or mechanics to be employed in the classification or their representatives, and the contracting officer do not agree on the proposed classification and wage rate (including the amount designated for fringe benefits, where appropriate), the contracting officer shall refer the questions, including the views of all interested parties and the recommendation of the contracting officer, to the Wage and Hour Administrator for determination. The Wage and Hour Administrator, or an authorized representative, will issue a determination within 30 days of receipt and so advise the contracting officer or

will notify the contracting officer within the 30-day period that additional time is necessary.

(4) The wage rate (including fringe benefits where appropriate) determined pursuant to paragraphs 1.b.(2) or 1.b.(3) of this section, shall be paid to all workers performing work in the classification under this contract from the first day on which work is performed in the classification.

c. Whenever the minimum wage rate prescribed in the contract for a class of laborers or mechanics includes a fringe benefit which is not expressed as an hourly rate, the contractor shall either pay the benefit as stated in the wage determination or shall pay another bona fide fringe benefit or an hourly cash equivalent thereof.

d. If the contractor does not make payments to a trustee or other third person, the contractor may consider as part of the wages of any laborer or mechanic the amount of any costs reasonably anticipated in providing bona fide fringe benefits under a plan or program, Provided, That the Secretary of Labor has found, upon the written request of the contractor, that the applicable standards of the Davis-Bacon Act have been met. The Secretary of Labor may require the contractor to set aside in a separate account assets for the meeting of obligations under the plan or program.

2. Withholding

The contracting agency shall upon its own action or upon written request of an authorized representative of the Department of Labor, withhold or cause to be withheld from the contractor under this contract, or any other Federal contract with the same prime contractor, or any other federally-assisted contract subject to Davis-Bacon prevailing wage requirements, which is held by the same prime contractor, so much of the accrued payments or advances as may be considered necessary to pay laborers and mechanics, including apprentices, trainees, and helpers, employed by the contractor or any subcontractor the full amount of wages required by the contract. In the event of failure to pay any laborer or mechanic, including any apprentice, trainee, or helper, employed or working on the site of the work, all or part of the wages required by the contract, the contracting agency may, after written notice to the contractor, take such action as may be necessary to cause the suspension of any further payment, advance, or guarantee of funds until such violations have ceased.

3. Payrolls and basic records

a. Payrolls and basic records relating thereto shall be maintained by the contractor during the course of the work and preserved for a period of three years thereafter for all laborers and mechanics working at the site of the work. Such records shall contain the name, address, and social security number of each such worker, his or her correct classification, hourly rates of wages paid (including rates of contributions or costs anticipated for bona fide fringe benefits or cash equivalents thereof of the types described in section 1(b)(2)(B) of the Davis-Bacon Act), daily and weekly number of hours worked, deductions made and actual wages paid. Whenever the Secretary of Labor has found under 29 CFR 5.5(a)(1)(iv) that the wages of any laborer or mechanic include the amount of any costs reasonably anticipated in providing benefits under a plan or program described in section 1(b)(2)(B) of the Davis-

Bacon Act, the contractor shall maintain records which show that the commitment to provide such benefits is enforceable, that the plan or program is financially responsible, and that the plan or program has been communicated in writing to the laborers or mechanics affected, and records which show the costs anticipated or the actual cost incurred in providing such benefits. Contractors employing apprentices or trainees under approved programs shall maintain written evidence of the registration of apprenticeship programs and certification of trainee programs, the registration of the apprentices and trainees, and the ratios and wage rates prescribed in the applicable programs.

b.(1) The contractor shall submit weekly for each week in which any contract work is performed a copy of all payrolls to the contracting agency. The payrolls submitted shall set out accurately and completely all of the information required to be maintained under 29 CFR 5.5(a)(3)(i), except that full social security numbers and home addresses shall not be included on weekly transmittals. Instead the payrolls shall only need to include an individually identifying number for each employee (e.g. , the last four digits of the employee's social security number). The required weekly payroll information may be submitted in any form desired. Optional Form WH-347 is available for this purpose from the Wage and Hour Division Web site at <http://www.dol.gov/esa/whd/forms/wh347instr.htm> or its successor site. The prime contractor is responsible for the submission of copies of payrolls by all subcontractors. Contractors and subcontractors shall maintain the full social security number and current address of each covered worker, and shall provide them upon request to the contracting agency for transmission to the State DOT, the FHWA or the Wage and Hour Division of the Department of Labor for purposes of an investigation or audit of compliance with prevailing wage requirements. It is not a violation of this section for a prime contractor to require a subcontractor to provide addresses and social security numbers to the prime contractor for its own records, without weekly submission to the contracting agency..

(2) Each payroll submitted shall be accompanied by a "Statement of Compliance," signed by the contractor or subcontractor or his or her agent who pays or supervises the payment of the persons employed under the contract and shall certify the following:

(i) That the payroll for the payroll period contains the information required to be provided under §5.5 (a)(3)(ii) of Regulations, 29 CFR part 5, the appropriate information is being maintained under §5.5 (a)(3)(i) of Regulations, 29 CFR part 5, and that such information is correct and complete;

(ii) That each laborer or mechanic (including each helper, apprentice, and trainee) employed on the contract during the payroll period has been paid the full weekly wages earned, without rebate, either directly or indirectly, and that no deductions have been made either directly or indirectly from the full wages earned, other than permissible deductions as set forth in Regulations, 29 CFR part 3;

(iii) That each laborer or mechanic has been paid not less than the applicable wage rates and fringe benefits or cash equivalents for the classification of work performed, as specified in the applicable wage determination incorporated into the contract.

(3) The weekly submission of a properly executed certification set forth on the reverse side of Optional Form WH-347 shall satisfy the requirement for submission of the "Statement of Compliance" required by paragraph 3.b.(2) of this section.

(4) The falsification of any of the above certifications may subject the contractor or subcontractor to civil or criminal prosecution under section 1001 of title 18 and section 231 of title 31 of the United States Code.

c. The contractor or subcontractor shall make the records required under paragraph 3.a. of this section available for inspection, copying, or transcription by authorized representatives of the contracting agency, the State DOT, the FHWA, or the Department of Labor, and shall permit such representatives to interview employees during working hours on the job. If the contractor or subcontractor fails to submit the required records or to make them available, the FHWA may, after written notice to the contractor, the contracting agency or the State DOT, take such action as may be necessary to cause the suspension of any further payment, advance, or guarantee of funds. Furthermore, failure to submit the required records upon request or to make such records available may be grounds for debarment action pursuant to 29 CFR 5.12.

4. Apprentices and trainees

a. Apprentices (programs of the USDOL).

Apprentices will be permitted to work at less than the predetermined rate for the work they performed when they are employed pursuant to and individually registered in a bona fide apprenticeship program registered with the U.S. Department of Labor, Employment and Training Administration, Office of Apprenticeship Training, Employer and Labor Services, or with a State Apprenticeship Agency recognized by the Office, or if a person is employed in his or her first 90 days of probationary employment as an apprentice in such an apprenticeship program, who is not individually registered in the program, but who has been certified by the Office of Apprenticeship Training, Employer and Labor Services or a State Apprenticeship Agency (where appropriate) to be eligible for probationary employment as an apprentice.

The allowable ratio of apprentices to journeymen on the job site in any craft classification shall not be greater than the ratio permitted to the contractor as to the entire work force under the registered program. Any worker listed on a payroll at an apprentice wage rate, who is not registered or otherwise employed as stated above, shall be paid not less than the applicable wage rate on the wage determination for the classification of work actually performed. In addition, any apprentice performing work on the job site in excess of the ratio permitted under the registered program shall be paid not less than the applicable wage rate on the wage determination for the work actually performed. Where a contractor is performing construction on a project in a locality other than that in which its program is registered, the ratios and wage rates (expressed in percentages of the journeyman's hourly rate) specified in the contractor's or subcontractor's registered program shall be observed.

Every apprentice must be paid at not less than the rate specified in the registered program for the apprentice's level of progress, expressed as a percentage of the journeymen hourly

rate specified in the applicable wage determination. Apprentices shall be paid fringe benefits in accordance with the provisions of the apprenticeship program. If the apprenticeship program does not specify fringe benefits, apprentices must be paid the full amount of fringe benefits listed on the wage determination for the applicable classification. If the Administrator determines that a different practice prevails for the applicable apprentice classification, fringes shall be paid in accordance with that determination.

In the event the Office of Apprenticeship Training, Employer and Labor Services, or a State Apprenticeship Agency recognized by the Office, withdraws approval of an apprenticeship program, the contractor will no longer be permitted to utilize apprentices at less than the applicable predetermined rate for the work performed until an acceptable program is approved.

b. Trainees (programs of the USDOL).

Except as provided in 29 CFR 5.16, trainees will not be permitted to work at less than the predetermined rate for the work performed unless they are employed pursuant to and individually registered in a program which has received prior approval, evidenced by formal certification by the U.S. Department of Labor, Employment and Training Administration.

The ratio of trainees to journeymen on the job site shall not be greater than permitted under the plan approved by the Employment and Training Administration.

Every trainee must be paid at not less than the rate specified in the approved program for the trainee's level of progress, expressed as a percentage of the journeyman hourly rate specified in the applicable wage determination. Trainees shall be paid fringe benefits in accordance with the provisions of the trainee program. If the trainee program does not mention fringe benefits, trainees shall be paid the full amount of fringe benefits listed on the wage determination unless the Administrator of the Wage and Hour Division determines that there is an apprenticeship program associated with the corresponding journeyman wage rate on the wage determination which provides for less than full fringe benefits for apprentices. Any employee listed on the payroll at a trainee rate who is not registered and participating in a training plan approved by the Employment and Training Administration shall be paid not less than the applicable wage rate on the wage determination for the classification of work actually performed. In addition, any trainee performing work on the job site in excess of the ratio permitted under the registered program shall be paid not less than the applicable wage rate on the wage determination for the work actually performed.

In the event the Employment and Training Administration withdraws approval of a training program, the contractor will no longer be permitted to utilize trainees at less than the applicable predetermined rate for the work performed until an acceptable program is approved.

c. Equal employment opportunity. The utilization of apprentices, trainees and journeymen under this part shall be in conformity with the equal employment opportunity requirements of Executive Order 11246, as amended, and 29 CFR part 30.

d. Apprentices and Trainees (programs of the U.S. DOT).

Apprentices and trainees working under apprenticeship and skill training programs which have been certified by the Secretary of Transportation as promoting EEO in connection with Federal-aid highway construction programs are not subject to the requirements of paragraph 4 of this Section IV. The straight time hourly wage rates for apprentices and trainees under such programs will be established by the particular programs. The ratio of apprentices and trainees to journeymen shall not be greater than permitted by the terms of the particular program.

5. Compliance with Copeland Act requirements. The contractor shall comply with the requirements of 29 CFR part 3, which are incorporated by reference in this contract.

6. Subcontracts. The contractor or subcontractor shall insert Form FHWA-1273 in any subcontracts and also require the subcontractors to include Form FHWA-1273 in any lower tier subcontracts. The prime contractor shall be responsible for the compliance by any subcontractor or lower tier subcontractor with all the contract clauses in 29 CFR 5.5.

7. Contract termination: debarment. A breach of the contract clauses in 29 CFR 5.5 may be grounds for termination of the contract, and for debarment as a contractor and a subcontractor as provided in 29 CFR 5.12.

8. Compliance with Davis-Bacon and Related Act requirements. All rulings and interpretations of the Davis-Bacon and Related Acts contained in 29 CFR parts 1, 3, and 5 are herein incorporated by reference in this contract.

9. Disputes concerning labor standards. Disputes arising out of the labor standards provisions of this contract shall not be subject to the general disputes clause of this contract. Such disputes shall be resolved in accordance with the procedures of the Department of Labor set forth in 29 CFR parts 5, 6, and 7. Disputes within the meaning of this clause include disputes between the contractor (or any of its subcontractors) and the contracting agency, the U.S. Department of Labor, or the employees or their representatives.

10. Certification of eligibility.

a. By entering into this contract, the contractor certifies that neither it (nor he or she) nor any person or firm who has an interest in the contractor's firm is a person or firm ineligible to be awarded Government contracts by virtue of section 3(a) of the Davis-Bacon Act or 29 CFR 5.12(a)(1).

b. No part of this contract shall be subcontracted to any person or firm ineligible for award of a Government contract by virtue of section 3(a) of the Davis-Bacon Act or 29 CFR 5.12(a)(1).

c. The penalty for making false statements is prescribed in the U.S. Criminal Code, 18 U.S.C. 1001.

V. CONTRACT WORK HOURS AND SAFETY STANDARDS ACT

The following clauses apply to any Federal-aid construction contract in an amount in excess of \$100,000 and subject to the overtime provisions of the Contract Work Hours and Safety Standards Act. These clauses shall be inserted in addition to the clauses required by 29 CFR 5.5(a) or 29 CFR 4.6. As used in this paragraph, the terms laborers and mechanics include watchmen and guards.

1. Overtime requirements. No contractor or subcontractor contracting for any part of the contract work which may require or involve the employment of laborers or mechanics shall require or permit any such laborer or mechanic in any workweek in which he or she is employed on such work to work in excess of forty hours in such workweek unless such laborer or mechanic receives compensation at a rate not less than one and one-half times the basic rate of pay for all hours worked in excess of forty hours in such workweek.

2. Violation; liability for unpaid wages; liquidated damages. In the event of any violation of the clause set forth in paragraph (1.) of this section, the contractor and any subcontractor responsible therefor shall be liable for the unpaid wages. In addition, such contractor and subcontractor shall be liable to the United States (in the case of work done under contract for the District of Columbia or a territory, to such District or to such territory), for liquidated damages. Such liquidated damages shall be computed with respect to each individual laborer or mechanic, including watchmen and guards, employed in violation of the clause set forth in paragraph (1.) of this section, in the sum of \$10 for each calendar day on which such individual was required or permitted to work in excess of the standard workweek of forty hours without payment of the overtime wages required by the clause set forth in paragraph (1.) of this section.

3. Withholding for unpaid wages and liquidated damages. The FHWA or the contacting agency shall upon its own action or upon written request of an authorized representative of the Department of Labor withhold or cause to be withheld, from any moneys payable on account of work performed by the contractor or subcontractor under any such contract or any other Federal contract with the same prime contractor, or any other federally-assisted contract subject to the Contract Work Hours and Safety Standards Act, which is held by the same prime contractor, such sums as may be determined to be necessary to satisfy any liabilities of such contractor or subcontractor for unpaid wages and liquidated damages as provided in the clause set forth in paragraph (2.) of this section.

4. Subcontracts. The contractor or subcontractor shall insert in any subcontracts the clauses set forth in paragraph (1.) through (4.) of this section and also a clause requiring the subcontractors to include these clauses in any lower tier subcontracts. The prime contractor shall be responsible for compliance by any subcontractor or lower tier subcontractor with the clauses set forth in paragraphs (1.) through (4.) of this section.

VI. SUBLETTING OR ASSIGNING THE CONTRACT

This provision is applicable to all Federal-aid construction contracts on the National Highway System.

1. The contractor shall perform with its own organization contract work amounting to not less than 30 percent (or a greater percentage if specified elsewhere in the contract) of the total original contract price, excluding any specialty items designated by the contracting agency. Specialty items may be performed by subcontract and the amount of any such specialty items performed may be deducted from the total original contract price before computing the amount of work required to be performed by the contractor's own organization (23 CFR 635.116).

a. The term "perform work with its own organization" refers to workers employed or leased by the prime contractor, and equipment owned or rented by the prime contractor, with or without operators. Such term does not include employees or equipment of a subcontractor or lower tier subcontractor, agents of the prime contractor, or any other assignees. The term may include payments for the costs of hiring leased employees from an employee leasing firm meeting all relevant Federal and State regulatory requirements. Leased employees may only be included in this term if the prime contractor meets all of the following conditions:

- (1) the prime contractor maintains control over the supervision of the day-to-day activities of the leased employees;
- (2) the prime contractor remains responsible for the quality of the work of the leased employees;
- (3) the prime contractor retains all power to accept or exclude individual employees from work on the project; and
- (4) the prime contractor remains ultimately responsible for the payment of predetermined minimum wages, the submission of payrolls, statements of compliance and all other Federal regulatory requirements.

b. "Specialty Items" shall be construed to be limited to work that requires highly specialized knowledge, abilities, or equipment not ordinarily available in the type of contracting organizations qualified and expected to bid or propose on the contract as a whole and in general are to be limited to minor components of the overall contract.

2. The contract amount upon which the requirements set forth in paragraph (1) of Section VI is computed includes the cost of material and manufactured products which are to be purchased or produced by the contractor under the contract provisions.

3. The contractor shall furnish (a) a competent superintendent or supervisor who is employed by the firm, has full authority to direct performance of the work in accordance with the contract requirements, and is in charge of all construction operations (regardless of who performs the work) and (b) such other of its own organizational resources (supervision, management, and engineering services) as the contracting officer determines is necessary to assure the performance of the contract.

4. No portion of the contract shall be sublet, assigned or otherwise disposed of except with the written consent of the contracting officer, or authorized representative, and such consent when given shall not be construed to relieve the contractor of any responsibility for the fulfillment of the contract. Written consent will be given only after the contracting agency has assured that each subcontract is

evidenced in writing and that it contains all pertinent provisions and requirements of the prime contract.

5. The 30% self-performance requirement of paragraph (1) is not applicable to design-build contracts; however, contracting agencies may establish their own self-performance requirements.

VII. SAFETY: ACCIDENT PREVENTION

This provision is applicable to all Federal-aid construction contracts and to all related subcontracts.

1. In the performance of this contract the contractor shall comply with all applicable Federal, State, and local laws governing safety, health, and sanitation (23 CFR 635). The contractor shall provide all safeguards, safety devices and protective equipment and take any other needed actions as it determines, or as the contracting officer may determine, to be reasonably necessary to protect the life and health of employees on the job and the safety of the public and to protect property in connection with the performance of the work covered by the contract.

2. It is a condition of this contract, and shall be made a condition of each subcontract, which the contractor enters into pursuant to this contract, that the contractor and any subcontractor shall not permit any employee, in performance of the contract, to work in surroundings or under conditions which are unsanitary, hazardous or dangerous to his/her health or safety, as determined under construction safety and health standards (29 CFR 1926) promulgated by the Secretary of Labor, in accordance with Section 107 of the Contract Work Hours and Safety Standards Act (40 U.S.C. 3704).

3. Pursuant to 29 CFR 1926.3, it is a condition of this contract that the Secretary of Labor or authorized representative thereof, shall have right of entry to any site of contract performance to inspect or investigate the matter of compliance with the construction safety and health standards and to carry out the duties of the Secretary under Section 107 of the Contract Work Hours and Safety Standards Act (40 U.S.C.3704).

VIII. FALSE STATEMENTS CONCERNING HIGHWAY PROJECTS

This provision is applicable to all Federal-aid construction contracts and to all related subcontracts.

In order to assure high quality and durable construction in conformity with approved plans and specifications and a high degree of reliability on statements and representations made by engineers, contractors, suppliers, and workers on Federal-aid highway projects, it is essential that all persons concerned with the project perform their functions as carefully, thoroughly, and honestly as possible. Willful falsification, distortion, or misrepresentation with respect to any facts related to the project is a violation of Federal law. To prevent any misunderstanding regarding the seriousness of these and similar acts, Form FHWA-1022 shall be posted on each Federal-aid highway project (23 CFR 635) in one or more places where it is readily available to all persons concerned with the project:

18 U.S.C. 1020 reads as follows:

"Whoever, being an officer, agent, or employee of the United States, or of any State or Territory, or whoever, whether a person, association, firm, or corporation, knowingly makes any false statement, false representation, or false report as to the character, quality, quantity, or cost of the material used or to be used, or the quantity or quality of the work performed or to be performed, or the cost thereof in connection with the submission of plans, maps, specifications, contracts, or costs of construction on any highway or related project submitted for approval to the Secretary of Transportation; or

Whoever knowingly makes any false statement, false representation, false report or false claim with respect to the character, quality, quantity, or cost of any work performed or to be performed, or materials furnished or to be furnished, in connection with the construction of any highway or related project approved by the Secretary of Transportation; or

Whoever knowingly makes any false statement or false representation as to material fact in any statement, certificate, or report submitted pursuant to provisions of the Federal-aid Roads Act approved July 1, 1916, (39 Stat. 355), as amended and supplemented;

Shall be fined under this title or imprisoned not more than 5 years or both."

IX. IMPLEMENTATION OF CLEAN AIR ACT AND FEDERAL WATER POLLUTION CONTROL ACT

This provision is applicable to all Federal-aid construction contracts and to all related subcontracts.

By submission of this bid/proposal or the execution of this contract, or subcontract, as appropriate, the bidder, proposer, Federal-aid construction contractor, or subcontractor, as appropriate, will be deemed to have stipulated as follows:

1. That any person who is or will be utilized in the performance of this contract is not prohibited from receiving an award due to a violation of Section 508 of the Clean Water Act or Section 306 of the Clean Air Act.
2. That the contractor agrees to include or cause to be included the requirements of paragraph (1) of this Section X in every subcontract, and further agrees to take such action as the contracting agency may direct as a means of enforcing such requirements.

X. CERTIFICATION REGARDING DEBARMENT, SUSPENSION, INELIGIBILITY AND VOLUNTARY EXCLUSION

This provision is applicable to all Federal-aid construction contracts, design-build contracts, subcontracts, lower-tier subcontracts, purchase orders, lease agreements, consultant contracts or any other covered transaction requiring FHWA approval or that is estimated to cost \$25,000 or more – as defined in 2 CFR Parts 180 and 1200.

1. Instructions for Certification – First Tier Participants:

- a. By signing and submitting this proposal, the prospective first tier participant is providing the certification set out below.
- b. The inability of a person to provide the certification set out below will not necessarily result in denial of participation in this

covered transaction. The prospective first tier participant shall submit an explanation of why it cannot provide the certification set out below. The certification or explanation will be considered in connection with the department or agency's determination whether to enter into this transaction. However, failure of the prospective first tier participant to furnish a certification or an explanation shall disqualify such a person from participation in this transaction.

c. The certification in this clause is a material representation of fact upon which reliance was placed when the contracting agency determined to enter into this transaction. If it is later determined that the prospective participant knowingly rendered an erroneous certification, in addition to other remedies available to the Federal Government, the contracting agency may terminate this transaction for cause of default.

d. The prospective first tier participant shall provide immediate written notice to the contracting agency to whom this proposal is submitted if any time the prospective first tier participant learns that its certification was erroneous when submitted or has become erroneous by reason of changed circumstances.

e. The terms "covered transaction," "debarred," "suspended," "ineligible," "participant," "person," "principal," and "voluntarily excluded," as used in this clause, are defined in 2 CFR Parts 180 and 1200. "First Tier Covered Transactions" refers to any covered transaction between a grantee or subgrantee of Federal funds and a participant (such as the prime or general contract). "Lower Tier Covered Transactions" refers to any covered transaction under a First Tier Covered Transaction (such as subcontracts). "First Tier Participant" refers to the participant who has entered into a covered transaction with a grantee or subgrantee of Federal funds (such as the prime or general contractor). "Lower Tier Participant" refers any participant who has entered into a covered transaction with a First Tier Participant or other Lower Tier Participants (such as subcontractors and suppliers).

f. The prospective first tier participant agrees by submitting this proposal that, should the proposed covered transaction be entered into, it shall not knowingly enter into any lower tier covered transaction with a person who is debarred, suspended, declared ineligible, or voluntarily excluded from participation in this covered transaction, unless authorized by the department or agency entering into this transaction.

g. The prospective first tier participant further agrees by submitting this proposal that it will include the clause titled "Certification Regarding Debarment, Suspension, Ineligibility and Voluntary Exclusion-Lower Tier Covered Transactions," provided by the department or contracting agency, entering into this covered transaction, without modification, in all lower tier covered transactions and in all solicitations for lower tier covered transactions exceeding the \$25,000 threshold.

h. A participant in a covered transaction may rely upon a certification of a prospective participant in a lower tier covered transaction that is not debarred, suspended, ineligible, or voluntarily excluded from the covered transaction, unless it knows that the certification is erroneous. A participant is responsible for ensuring that its principals are not suspended, debarred, or otherwise ineligible to participate in covered transactions. To verify the eligibility of its principals, as well as the eligibility of any lower tier prospective participants, each participant may, but is not required to, check the Excluded Parties List System website (<https://www.epls.gov/>), which is compiled by the General Services Administration.

i. Nothing contained in the foregoing shall be construed to require the establishment of a system of records in order to render in good faith the certification required by this clause. The knowledge and information of the prospective participant is not required to exceed that which is normally possessed by a prudent person in the ordinary course of business dealings.

j. Except for transactions authorized under paragraph (f) of these instructions, if a participant in a covered transaction knowingly enters into a lower tier covered transaction with a person who is suspended, debarred, ineligible, or voluntarily excluded from participation in this transaction, in addition to other remedies available to the Federal Government, the department or agency may terminate this transaction for cause or default.

* * * * *

2. Certification Regarding Debarment, Suspension, Ineligibility and Voluntary Exclusion – First Tier Participants:

a. The prospective first tier participant certifies to the best of its knowledge and belief, that it and its principals:

(1) Are not presently debarred, suspended, proposed for debarment, declared ineligible, or voluntarily excluded from participating in covered transactions by any Federal department or agency;

(2) Have not within a three-year period preceding this proposal been convicted of or had a civil judgment rendered against them for commission of fraud or a criminal offense in connection with obtaining, attempting to obtain, or performing a public (Federal, State or local) transaction or contract under a public transaction; violation of Federal or State antitrust statutes or commission of embezzlement, theft, forgery, bribery, falsification or destruction of records, making false statements, or receiving stolen property;

(3) Are not presently indicted for or otherwise criminally or civilly charged by a governmental entity (Federal, State or local) with commission of any of the offenses enumerated in paragraph (a)(2) of this certification; and

(4) Have not within a three-year period preceding this application/proposal had one or more public transactions (Federal, State or local) terminated for cause or default.

b. Where the prospective participant is unable to certify to any of the statements in this certification, such prospective participant shall attach an explanation to this proposal.

2. Instructions for Certification - Lower Tier Participants:

(Applicable to all subcontracts, purchase orders and other lower tier transactions requiring prior FHWA approval or estimated to cost \$25,000 or more - 2 CFR Parts 180 and 1200)

a. By signing and submitting this proposal, the prospective lower tier is providing the certification set out below.

b. The certification in this clause is a material representation of fact upon which reliance was placed when this transaction was entered into. If it is later determined that the prospective lower tier participant knowingly rendered an erroneous certification, in addition to other remedies available to the Federal Government, the department, or agency with which

this transaction originated may pursue available remedies, including suspension and/or debarment.

c. The prospective lower tier participant shall provide immediate written notice to the person to which this proposal is submitted if at any time the prospective lower tier participant learns that its certification was erroneous by reason of changed circumstances.

d. The terms "covered transaction," "debarred," "suspended," "ineligible," "participant," "person," "principal," and "voluntarily excluded," as used in this clause, are defined in 2 CFR Parts 180 and 1200. You may contact the person to which this proposal is submitted for assistance in obtaining a copy of those regulations. "First Tier Covered Transactions" refers to any covered transaction between a grantee or subgrantee of Federal funds and a participant (such as the prime or general contract). "Lower Tier Covered Transactions" refers to any covered transaction under a First Tier Covered Transaction (such as subcontracts). "First Tier Participant" refers to the participant who has entered into a covered transaction with a grantee or subgrantee of Federal funds (such as the prime or general contractor). "Lower Tier Participant" refers any participant who has entered into a covered transaction with a First Tier Participant or other Lower Tier Participants (such as subcontractors and suppliers).

e. The prospective lower tier participant agrees by submitting this proposal that, should the proposed covered transaction be entered into, it shall not knowingly enter into any lower tier covered transaction with a person who is debarred, suspended, declared ineligible, or voluntarily excluded from participation in this covered transaction, unless authorized by the department or agency with which this transaction originated.

f. The prospective lower tier participant further agrees by submitting this proposal that it will include this clause titled "Certification Regarding Debarment, Suspension, Ineligibility and Voluntary Exclusion-Lower Tier Covered Transaction," without modification, in all lower tier covered transactions and in all solicitations for lower tier covered transactions exceeding the \$25,000 threshold.

g. A participant in a covered transaction may rely upon a certification of a prospective participant in a lower tier covered transaction that is not debarred, suspended, ineligible, or voluntarily excluded from the covered transaction, unless it knows that the certification is erroneous. A participant is responsible for ensuring that its principals are not suspended, debarred, or otherwise ineligible to participate in covered transactions. To verify the eligibility of its principals, as well as the eligibility of any lower tier prospective participants, each participant may, but is not required to, check the Excluded Parties List System website (<https://www.epls.gov/>), which is compiled by the General Services Administration.

h. Nothing contained in the foregoing shall be construed to require establishment of a system of records in order to render in good faith the certification required by this clause. The knowledge and information of participant is not required to exceed that which is normally possessed by a prudent person in the ordinary course of business dealings.

i. Except for transactions authorized under paragraph e of these instructions, if a participant in a covered transaction knowingly enters into a lower tier covered transaction with a person who is suspended, debarred, ineligible, or voluntarily excluded from participation in this transaction, in addition to other remedies available to the Federal Government, the

department or agency with which this transaction originated may pursue available remedies, including suspension and/or debarment.

Certification Regarding Debarment, Suspension, Ineligibility and Voluntary Exclusion—Lower Tier Participants:

1. The prospective lower tier participant certifies, by submission of this proposal, that neither it nor its principals is presently debarred, suspended, proposed for debarment, declared ineligible, or voluntarily excluded from participating in covered transactions by any Federal department or agency.

2. Where the prospective lower tier participant is unable to certify to any of the statements in this certification, such prospective participant shall attach an explanation to this proposal.

XI. CERTIFICATION REGARDING USE OF CONTRACT FUNDS FOR LOBBYING

This provision is applicable to all Federal-aid construction contracts and to all related subcontracts which exceed \$100,000 (49 CFR 20).

1. The prospective participant certifies, by signing and submitting this bid or proposal, to the best of his or her knowledge and belief, that:

a. No Federal appropriated funds have been paid or will be paid, by or on behalf of the undersigned, to any person for influencing or attempting to influence an officer or employee of any Federal agency, a Member of Congress, an officer or employee of Congress, or an employee of a Member of Congress in connection with the awarding of any Federal contract, the making of any Federal grant, the making of any Federal loan, the entering into of any cooperative agreement, and the extension, continuation, renewal, amendment, or modification of any Federal contract, grant, loan, or cooperative agreement.

b. If any funds other than Federal appropriated funds have been paid or will be paid to any person for influencing or attempting to influence an officer or employee of any Federal agency, a Member of Congress, an officer or employee of Congress, or an employee of a Member of Congress in connection with this Federal contract, grant, loan, or cooperative agreement, the undersigned shall complete and submit Standard Form-LLL, "Disclosure Form to Report Lobbying," in accordance with its instructions.

2. This certification is a material representation of fact upon which reliance was placed when this transaction was made or entered into. Submission of this certification is a prerequisite for making or entering into this transaction imposed by 31 U.S.C. 1352. Any person who fails to file the required certification shall be subject to a civil penalty of not less than \$10,000 and not more than \$100,000 for each such failure.

3. The prospective participant also agrees by submitting its bid or proposal that the participant shall require that the language of this certification be included in all lower tier subcontracts, which exceed \$100,000 and that all such recipients shall certify and disclose accordingly.

ATTACHMENT A - EMPLOYMENT AND MATERIALS PREFERENCE FOR APPALACHIAN DEVELOPMENT HIGHWAY SYSTEM OR APPALACHIAN LOCAL ACCESS ROAD CONTRACTS

This provision is applicable to all Federal-aid projects funded under the Appalachian Regional Development Act of 1965.

1. During the performance of this contract, the contractor undertaking to do work which is, or reasonably may be, done as on-site work, shall give preference to qualified persons who regularly reside in the labor area as designated by the DOL wherein the contract work is situated, or the subregion, or the Appalachian counties of the State wherein the contract work is situated, except:

a. To the extent that qualified persons regularly residing in the area are not available.

b. For the reasonable needs of the contractor to employ supervisory or specially experienced personnel necessary to assure an efficient execution of the contract work.

c. For the obligation of the contractor to offer employment to present or former employees as the result of a lawful collective bargaining contract, provided that the number of nonresident persons employed under this subparagraph (1c) shall not exceed 20 percent of the total number of employees employed by the contractor on the contract work, except as provided in subparagraph (4) below.

2. The contractor shall place a job order with the State Employment Service indicating (a) the classifications of the laborers, mechanics and other employees required to perform the contract work, (b) the number of employees required in each classification, (c) the date on which the participant estimates such employees will be required, and (d) any other pertinent information required by the State Employment Service to complete the job order form. The job order may be placed with the State Employment Service in writing or by telephone. If during the course of the contract work, the information submitted by the contractor in the original job order is substantially modified, the participant shall promptly notify the State Employment Service.

3. The contractor shall give full consideration to all qualified job applicants referred to him by the State Employment Service. The contractor is not required to grant employment to any job applicants who, in his opinion, are not qualified to perform the classification of work required.

4. If, within one week following the placing of a job order by the contractor with the State Employment Service, the State Employment Service is unable to refer any qualified job applicants to the contractor, or less than the number requested, the State Employment Service will forward a certificate to the contractor indicating the unavailability of applicants. Such certificate shall be made a part of the contractor's permanent project records. Upon receipt of this certificate, the contractor may employ persons who do not normally reside in the labor area to fill positions covered by the certificate, notwithstanding the provisions of subparagraph (1c) above.

5. The provisions of 23 CFR 633.207(e) allow the contracting agency to provide a contractual preference for the use of mineral resource materials native to the Appalachian region.

6. The contractor shall include the provisions of Sections 1 through 4 of this Attachment A in every subcontract for work which is, or reasonably may be, done as on-site work.

"General Decision Number: FL20220193 01/07/2022

Superseded General Decision Number: FL20210193

State: Florida

Construction Type: Highway

Counties: Baker and Nassau Counties in Florida.

HIGHWAY CONSTRUCTION PROJECTS

Note: Contracts subject to the Davis-Bacon Act are generally required to pay at least the applicable minimum wage rate required under Executive Order 14026 or Executive Order 13658. Please note that these Executive Orders apply to covered contracts entered into by the federal government that are subject to the Davis-Bacon Act itself, but do not apply to contracts subject only to the Davis-Bacon Related Acts, including those set forth at 29 CFR 5.1(a)(2)-(60).

If the contract is entered into on or after January 30, 2022, or the contract is renewed or extended (e.g., an option is exercised) on or after January 30, 2022, Executive Order 14026 generally applies to the contract. The contractor must pay all covered workers at least \$15.00 per hour (or the applicable wage rate listed on this wage determination, if it is higher) for all hours spent performing on that contract in 2022.

If the contract was awarded on or between January 1, 2015 and January 29, 2022, and the contract is not renewed or extended on or after January 30, 2022, Executive Order 13658 generally applies to the contract. The contractor must pay all covered workers at least \$11.25 per hour (or the applicable wage rate listed on this wage determination, if it is higher) for all hours spent performing on that contract in 2022.

The applicable Executive Order minimum wage rate will be adjusted annually. If this contract is covered by one of the Executive Orders and a classification considered necessary for performance of work on the contract does not appear on this wage determination, the contractor must still submit a conformance request.

Additional information on contractor requirements and worker protections under the Executive Orders is available at www.dol.gov/whd/govcontracts.

Modification Number	Publication Date
0	01/07/2022

* SUFL2013-054 08/19/2013

	Rates	Fringes
CARPENTER, Includes Form Work....	\$ 14.14	0.00

CEMENT MASON/CONCRETE FINISHER...\$ 14.35	0.00
ELECTRICIAN.....\$ 21.87	0.00
FENCE ERECTOR.....\$ 11.41	0.00
HIGHWAY/PARKING LOT STRIPING: Operator (Striping Machine).....\$ 12.37	0.32
HIGHWAY/PARKING LOT STRIPING: Painter.....\$ 12.13	0.00
INSTALLER - GUARDRAIL.....\$ 11.94	0.00
IRONWORKER, ORNAMENTAL.....\$ 13.48	0.00
IRONWORKER, REINFORCING.....\$ 15.77	0.00
IRONWORKER, STRUCTURAL.....\$ 17.50	0.00
LABORER (Traffic Control Specialist).....\$ 10.94	0.00
LABORER: Asphalt, Includes Raker, Shoveler, Spreader and Distributor.....\$ 13.61	0.00
LABORER: Common or General.....\$ 10.70	0.00
LABORER: Concrete Saw (Hand Held/Walk Behind).....\$ 12.04	0.00
LABORER: Flagger.....\$ 12.02	0.00
LABORER: Grade Checker.....\$ 13.64	0.00
LABORER: Landscape & Irrigation.....\$ 11.48	0.00
LABORER: Mason Tender - Cement/Concrete.....\$ 12.81	0.00
LABORER: Pipelayer.....\$ 14.42	0.00
OPERATOR: Auger.....\$ 12.43	0.00
OPERATOR: Backhoe/Excavator/Trackhoe.....\$ 15.06	0.00
OPERATOR: Bobcat/Skid Steer/Skid Loader.....\$ 12.86	0.00
OPERATOR: Boom.....\$ 16.50	0.00
OPERATOR: Boring Machine.....\$ 17.18	0.00
OPERATOR: Broom/Sweeper.....\$ 11.60	0.00
OPERATOR: Bulldozer.....\$ 15.76	0.00
OPERATOR: Concrete Finishing Machine.....\$ 15.44	0.00
OPERATOR: Concrete Pump.....\$ 19.57	0.00

OPERATOR: Concrete Saw.....	\$ 15.09	0.00
OPERATOR: Crane.....	\$ 20.62	0.00
OPERATOR: Curb Machine.....	\$ 19.21	0.00
OPERATOR: Distributor.....	\$ 15.01	0.00
OPERATOR: Drill.....	\$ 14.71	0.00
OPERATOR: Forklift.....	\$ 12.02	0.00
OPERATOR: Gradall.....	\$ 14.71	0.00
OPERATOR: Grader/Blade.....	\$ 18.21	0.00
OPERATOR: Grinding/Grooving Machine.....	\$ 16.07	0.00
OPERATOR: Loader.....	\$ 14.07	0.00
OPERATOR: Mechanic.....	\$ 18.20	0.00
OPERATOR: Milling Machine.....	\$ 15.27	0.00
OPERATOR: Oiler.....	\$ 14.92	0.00
OPERATOR: Paver (Asphalt, Aggregate, and Concrete).....	\$ 15.32	0.00
OPERATOR: Piledriver.....	\$ 17.23	0.00
OPERATOR: Post Driver (Guardrail/Fences).....	\$ 20.22	0.00
OPERATOR: Roller.....	\$ 12.61	0.00
OPERATOR: Scraper.....	\$ 12.01	0.00
OPERATOR: Screed.....	\$ 14.97	0.00
OPERATOR: Tractor.....	\$ 12.91	0.00
OPERATOR: Trencher.....	\$ 20.17	0.00
PAINTER: Spray.....	\$ 19.57	0.00
TRAFFIC SIGNALIZATION: Traffic Signal Installation.....	\$ 16.36	0.00
TRUCK DRIVER: Dump Truck.....	\$ 13.47	0.00
TRUCK DRIVER: Flatbed Truck.....	\$ 14.28	0.00
TRUCK DRIVER: Lowboy Truck.....	\$ 15.85	0.00
TRUCK DRIVER: Slurry Truck.....	\$ 11.96	0.00
TRUCK DRIVER: Vactor Truck.....	\$ 13.70	0.00
TRUCK DRIVER: Water Truck.....	\$ 14.23	0.00

WELDERS - Receive rate prescribed for craft performing

operation to which welding is incidental.

=====

Note: Executive Order (EO) 13706, Establishing Paid Sick Leave for Federal Contractors applies to all contracts subject to the Davis-Bacon Act for which the contract is awarded (and any solicitation was issued) on or after January 1, 2017. If this contract is covered by the EO, the contractor must provide employees with 1 hour of paid sick leave for every 30 hours they work, up to 56 hours of paid sick leave each year. Employees must be permitted to use paid sick leave for their own illness, injury or other health-related needs, including preventive care; to assist a family member (or person who is like family to the employee) who is ill, injured, or has other health-related needs, including preventive care; or for reasons resulting from, or to assist a family member (or person who is like family to the employee) who is a victim of, domestic violence, sexual assault, or stalking. Additional information on contractor requirements and worker protections under the EO is available at www.dol.gov/whd/govcontracts.

Unlisted classifications needed for work not included within the scope of the classifications listed may be added after award only as provided in the labor standards contract clauses (29CFR 5.5 (a) (1) (ii)).

The body of each wage determination lists the classification and wage rates that have been found to be prevailing for the cited type(s) of construction in the area covered by the wage determination. The classifications are listed in alphabetical order of ""identifiers"" that indicate whether the particular rate is a union rate (current union negotiated rate for local), a survey rate (weighted average rate) or a union average rate (weighted union average rate).

Union Rate Identifiers

A four letter classification abbreviation identifier enclosed in dotted lines beginning with characters other than ""SU"" or ""UAVG"" denotes that the union classification and rate were prevailing for that classification in the survey. Example: PLUM0198-005 07/01/2014. PLUM is an abbreviation identifier of the union, which prevailed in the survey for this classification, which in this example would be Plumbers 0198 indicates the local union number or district council number where applicable, i.e., Plumbers Local 0198. The next number, 005 in the example, is an internal number used in processing the wage determination. 07/01/2014 is the effective date of the most current negotiated rate, which in this example is July 1, 2014.

Union prevailing wage rates are updated to reflect all rate changes in the collective bargaining agreement (CBA) governing this classification and rate.

Survey Rate Identifiers

Classifications listed under the ""SU"" identifier indicate that no one rate prevailed for this classification in the survey and the published rate is derived by computing a weighted average

rate based on all the rates reported in the survey for that classification. As this weighted average rate includes all rates reported in the survey, it may include both union and non-union rates. Example: SULA2012-007 5/13/2014. SU indicates the rates are survey rates based on a weighted average calculation of rates and are not majority rates. LA indicates the State of Louisiana. 2012 is the year of survey on which these classifications and rates are based. The next number, 007 in the example, is an internal number used in producing the wage determination. 5/13/2014 indicates the survey completion date for the classifications and rates under that identifier.

Survey wage rates are not updated and remain in effect until a new survey is conducted.

Union Average Rate Identifiers

Classification(s) listed under the UAVG identifier indicate that no single majority rate prevailed for those classifications; however, 100% of the data reported for the classifications was union data. EXAMPLE: UAVG-OH-0010 08/29/2014. UAVG indicates that the rate is a weighted union average rate. OH indicates the state. The next number, 0010 in the example, is an internal number used in producing the wage determination. 08/29/2014 indicates the survey completion date for the classifications and rates under that identifier.

A UAVG rate will be updated once a year, usually in January of each year, to reflect a weighted average of the current negotiated/CBA rate of the union locals from which the rate is based.

WAGE DETERMINATION APPEALS PROCESS

1.) Has there been an initial decision in the matter? This can be:

- * an existing published wage determination
- * a survey underlying a wage determination
- * a Wage and Hour Division letter setting forth a position on a wage determination matter
- * a conformance (additional classification and rate) ruling

On survey related matters, initial contact, including requests for summaries of surveys, should be with the Wage and Hour Division National Office Branch of Wage Surveys. If the response from this initial contact is not satisfactory, then the process described in 2.) and 3.) should be followed.

With regard to any other matter not yet ripe for the formal process described here, initial contact should be with the Branch of Construction Wage Determinations. Write to:

Branch of Construction Wage Determinations
Wage and Hour Division
U.S. Department of Labor
200 Constitution Avenue, N.W.
Washington, DC 20210

2.) If the answer to the question in 1.) is yes, then an interested party (those affected by the action) can request

review and reconsideration from the Wage and Hour Administrator (See 29 CFR Part 1.8 and 29 CFR Part 7). Write to:

Wage and Hour Administrator
U.S. Department of Labor
200 Constitution Avenue, N.W.
Washington, DC 20210

The request should be accompanied by a full statement of the interested party's position and by any information (wage payment data, project description, area practice material, etc.) that the requestor considers relevant to the issue.

3.) If the decision of the Administrator is not favorable, an interested party may appeal directly to the Administrative Review Board (formerly the Wage Appeals Board). Write to:

Administrative Review Board
U.S. Department of Labor
200 Constitution Avenue, N.W.
Washington, DC 20210

4.) All decisions by the Administrative Review Board are final.

=====

END OF GENERAL DECISION"